

# Revo

## Owner's Manual



*The Ultimate In Style & Performance<sup>®</sup>*

**Pride**  
Mobility Products Corp.

Exeter, PA  
St. Catharines, ON

1-800-800-8586

[www.pridemobility.com](http://www.pridemobility.com)

# SAFETY GUIDELINES

The symbols below are used throughout this owner's manual and on the scooter to identify warnings and important information. It is very important for you to read them and understand them completely.



**WARNING!** Indicates a potentially hazardous condition/situation that can cause personal injury, equipment and/or property damage (black symbol on yellow triangle with black border).



**MANDATORY!** These actions should be performed as specified. Failure to perform mandatory actions can cause injury to personnel and/or damage to equipment (white symbol on blue dot).



**PROHIBITED!** These actions are prohibited; do not perform at any time or in any situation. Performing a prohibited action can cause personal injury and/or equipment damage (black symbol with red circle and red slash).

Please fill out the following information for quick reference:

Pride Provider: _____
Purchase Date: _____
Address: _____
Phone Number: _____
Serial Number: _____

***NOTE: This owner's manual is compiled from the latest specifications and product information available at the time of publication. We reserve the right to make changes as they become necessary. Any changes to our products may cause slight variations between the illustrations and explanations in this manual and the product you have purchased.***



Copyright ©2005  
Pride Mobility Products Corp.

INFMANU2427/Rev F/October 2005

# CONTENTS

I. INTRODUCTION.....	4
II. SAFETY .....	5
III. EMI/RFI .....	16
IV. SPECIFICATIONS .....	17
V. YOUR SCOOTER .....	19
VI. BATTERIES AND CHARGING .....	22
VII. OPERATION.....	27
VIII. COMFORT ADJUSTMENTS.....	29
IX. DISASSEMBLY AND ASSEMBLY .....	31
X. BASIC TROUBLESHOOTING .....	34
XI. CARE AND MAINTENANCE .....	36
XII. WARRANTY .....	38

# I. INTRODUCTION

## SAFETY

WELCOME to Pride Mobility Products Corporation (Pride). The product you have purchased combines state-of-the-art components with **safety**, comfort and styling in mind. We are confident the design features will provide you with the conveniences you expect during your daily activities. Understanding how to **safely** operate and care for this product should bring you years of trouble free operations and service.

**Read and follow** all instructions, warnings, and notes in this manual and all other accompanying literature before attempting to operate this product for the first time. In addition, your **safety** depends upon you, as well as your provider, caretaker, or healthcare professional in using good judgement.

If there is any information in this manual which you do not understand, or if you require additional assistance for setup or operation, please contact your authorized Pride Provider. **Failure to follow the instructions, warnings, and notes in this manual and those located on your Pride product can result in personal injury or product damage and will void Pride's product warranty.**

## PURCHASER'S AGREEMENT

By accepting delivery of this product, you promise that you will not change, alter, or modify this product or remove or render inoperable or unsafe any guards, shields, or other safety features of this product; fail, refuse, or neglect to install any retrofit kits from time to time provided by Pride to enhance or preserve the safe use of this product.

## INFORMATION EXCHANGE

We want to hear your questions, comments, and suggestions about this manual. We would also like to hear about the safety and reliability of your new scooter, and about the service you received from your authorized Pride Provider. Please notify us of any change of address, so we can keep you apprised of important information about safety, new products, and new options that can increase your ability to use and enjoy your scooter. Please feel free to contact us at the address below:

Pride Mobility Products Corporation  
Attn: Customer Care Department  
182 Susquehanna Ave.  
Exeter, PA 18643-2694

***NOTE: If you ever lose or misplace your product registration card or your copy of this manual, contact us and we will be glad to send you a new one immediately.***

## PRIDE OWNERS CLUB

As an owner of a Pride product, you are encouraged to enroll in the Pride Owners Club. Complete and return your enclosed product registration card or visit Pride's web site at [www.pridemobility.com](http://www.pridemobility.com).

From our home page, select "Owners Club" to enter a page dedicated to current and potential Pride product owners. You will gain access to interviews, stories, recreation ideas, daily living tips, product and funding information, and interactive message boards. These message boards invite you to communicate with other Pride customers as well as Pride representatives who are available to assist you with any questions or concerns.

# II. SAFETY

## PRODUCT SAFETY SYMBOLS

The symbols below are used on the scooter to identify warnings, mandatory actions, and prohibited actions. It is very important for you to read and understand them completely.



Read and follow the information in the owner's manual.



Pinch/Crush points created during assembly.



Corrosive chemicals contained in battery. Use only AGM or Gel-Cell batteries to reduce the risk of leakage or explosive conditions.



EMI-RFI- This product has been tested and passed at an immunity level of 20 V/m.



Maximum seating weight.



Unlocked and in freewheel mode.

Place unit on level ground and stand behind or to one side when changing from drive mode to freewheel mode or freewheel mode to drive mode.

Locked and in drive mode.

## II. SAFETY

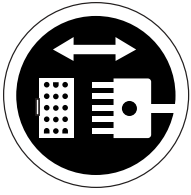

Front-to-rear plug orientation.



Do not remove anti-tip wheels.



Avoid exposure to rain, snow, ice, salt, or standing water whenever possible. Maintain and store in a clean and dry condition.



Removal of grounding prong can create electrical hazard. If necessary, properly install an approved 3-pronged adapter to an electrical outlet having 2-pronged plug access. Failure to heed could result in personal injury and/or property damage.

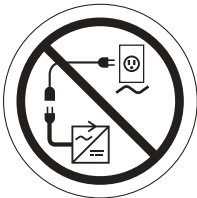

Prevent personal injury and equipment damage. Do not connect an extension cord to the AC/DC converter or the battery charger.



Do not use a cell phone, walkie/talkie, laptop, or other radio transmitter while operating.

# II. SAFETY

## GENERAL



**MANDATORY!** Do not operate your new scooter for the first time without completely reading and understanding this owner's manual.

Your scooter is a state-of-the-art life-enhancement device designed to increase mobility. Pride provides an extensive variety of products to best fit the individual needs of the scooter user. Please be aware that the final selection and purchasing decision regarding the type of scooter to be used is the responsibility of the scooter user who is capable of making such a decision and his/her healthcare professional (i.e., medical doctor, physical therapist, etc.).

The contents of this manual are based on the expectation that a mobility device expert has properly fitted the scooter to the user and has assisted the prescribing healthcare professional and/or the authorized Pride Provider in the instruction process for the use of the product.

There are certain situations, including some medical conditions, where the scooter user will need to practice operating the scooter in the presence of a trained attendant. A trained attendant can be defined as a family member or care professional specially trained in assisting a scooter user in various daily living activities.

As you begin using your scooter during daily activities, you will probably encounter situations in which you will need some practice. Simply take your time and you will soon be in full and confident control as you maneuver through doorways, on and off elevators, up and down ramps, and over moderate terrain.

Below are some precautions, tips, and other safety considerations that will help the user become accustomed to operating the scooter safely.

## MODIFICATIONS

Pride has designed and engineered your scooter to provide maximum mobility and utility. A wide range of accessories is available from your authorized Pride Provider to further customize your scooter to better suit your needs and/or preferences. However, under no circumstances should you modify, add, remove, or disable any feature, part, or function of your scooter.



**WARNING!** Do not modify your scooter in any way not authorized by Pride. Unauthorized modifications may result in personal injury and/or damage to your scooter.

## REMOVABLE PARTS



**WARNING!** Do not attempt to lift or move your scooter by any of its removable parts. Personal injury and damage to the scooter may result.

# II. SAFETY

## PRE-RIDE SAFETY CHECK

Get to know the feel of your scooter and its capabilities. Pride recommends that you perform a safety check before each use to make sure your scooter operates smoothly and safely.

Perform the following inspections prior to using your scooter:

- Check for proper tire inflation (if equipped with pneumatic tires).
- Check all electrical connections. Make sure they are tight and not corroded.
- Check all harness connections. Make sure they are secured properly.
- Check the brakes.
- Check battery charge.

If you discover a problem, contact your authorized Pride Provider for assistance.

## TIRE INFLATION

If your scooter is equipped with pneumatic tires, you should check or have the air pressure checked regularly. Proper inflation pressures will prolong the life of your tires and help ensure the smooth operation of your scooter.



**WARNING!** It is critically important that 30-35 psi tire pressure be maintained in pneumatic tires at all times. Do not underinflate or overinflate your tires. Low pressure may result in loss of control, and overinflated tires may burst. Failure to maintain 30-35 psi tire pressure in pneumatic tires at all times may result in tire and/or wheel failure, causing serious personal injury and/or damage to your scooter.

**WARNING!** Inflate your scooter tires from a regulated air source with an available pressure gauge. Inflating your tires from an unregulated air source could overinflate them, resulting in a burst tire and/or personal injury.

## WEIGHT LIMITATIONS

Your scooter is rated for a maximum weight capacity. Refer to the specifications table for information.



**WARNING!** Exceeding the weight capacity voids your warranty and may result in personal injury and damage to your scooter. Pride will not be held responsible for injuries and/or property damage resulting from failure to observe weight limitations.

**WARNING!** Do not carry passengers on your scooter. Carrying passengers may result in personal injury and/or property damage.

## INCLINE INFORMATION

More and more buildings have ramps with specified degrees of inclination, designed for easy and safe access. Some ramps may have turning switchbacks (180-degree turns) that require you to have good cornering skills on your scooter.

- Proceed with extreme caution as you approach the downgrade of a ramp or other incline.
- Take wide swings with your scooter around any tight corners. If you do that, the scooter's rear wheels will follow a wide arc, not cut the corner short, and not bump into or get hung up on any railing corners.
- When driving down a ramp, keep the scooter's speed adjustment set to the slowest speed setting to ensure a safely controlled descent.
- Avoid sudden stops and starts.



## II. SAFETY

When climbing an incline, try to keep your scooter moving. If you must stop, start up again slowly, and then accelerate cautiously. When driving down an incline, do so by setting the speed adjustment dial to the slowest setting and driving in the forward direction only. If your scooter starts to move down the incline faster than you anticipated or desired, allow it to come to a complete stop by releasing the throttle control lever. Then push the throttle control lever forward slightly to ensure a safely controlled descent.

**WARNING!** When climbing an incline, do not zigzag or drive at an angle up the face of the incline. Drive your scooter straight up the incline. This greatly reduces the possibility of a tip or a fall. Always exercise extreme caution when negotiating an incline.

**WARNING!** Do not drive your scooter across the side of an incline or diagonally up or down an incline; do not stop, if possible, while driving up or down an incline.



**WARNING!** You should not travel up or down a potentially hazardous incline (i.e., areas covered with snow, ice, cut grass, or wet leaves).

**WARNING!** When on any sort of an incline or decline, never place the scooter in freewheel mode while seated on it or standing next to it.

**WARNING!** Even though your scooter is capable of climbing slopes greater than those illustrated in figures 1, 1A, and 1B do not, under any circumstances, exceed the incline guidelines or any other specifications presented in this manual. Doing so could cause instability in your scooter, resulting in personal injury and/or damage to your scooter.

Handicap public access ramps are not subject to government regulation in all countries, and therefore do not necessarily share the same standard percent of slope. Other inclines may be natural or, if man-made, not designed specifically for scooters. Figures 1, 1A and 1B illustrate your scooter's stability and its ability to climb grades under various weight loads and under controlled testing conditions.

These tests were conducted with the scooter's seat in the highest position and adjusted rearward on the seat base to its farthest rearward position. Use this information as a guideline. Your scooter's ability to travel up inclines is affected by your weight, your scooter's speed, your angle of approach to the incline, and your scooter setup.

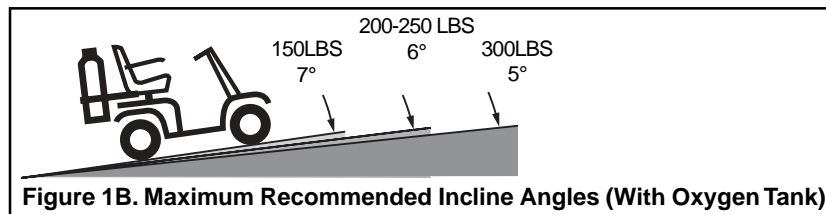
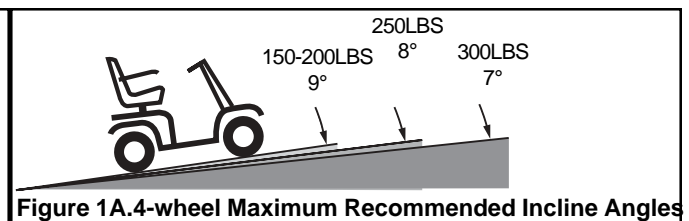
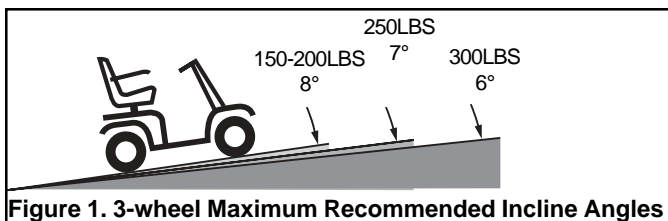

**WARNING!** Any attempt to climb or descend a slope steeper than what is shown in figures 1, 1A, and 1B may put your scooter in an unstable position and cause it to tip, resulting in personal injury.

**WARNING!** Never carry an oxygen tank weighing more than 13 lbs. Never fill the rear basket with contents exceeding 13 lbs.

## II. SAFETY

When you approach an incline, it is best to lean forward. See figures 2 and 2A. This shifts the center of gravity of you and your scooter toward the front of the scooter for improved stability.

**NOTE:** When negotiating ramps, if the throttle control lever is released while moving forward, the powered scooter may "rollback" approximately 1 foot before the brake engages. If the throttle control lever is released while moving in reverse, the powered scooter may "rollback" approximately one meter 3 feet before the brake engages.

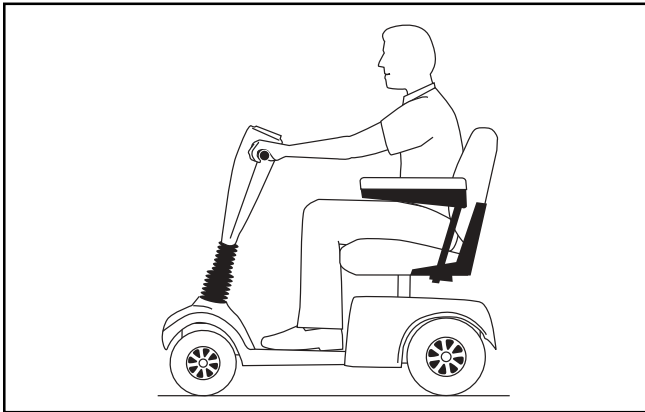

Figure 2. Normal Driving Position

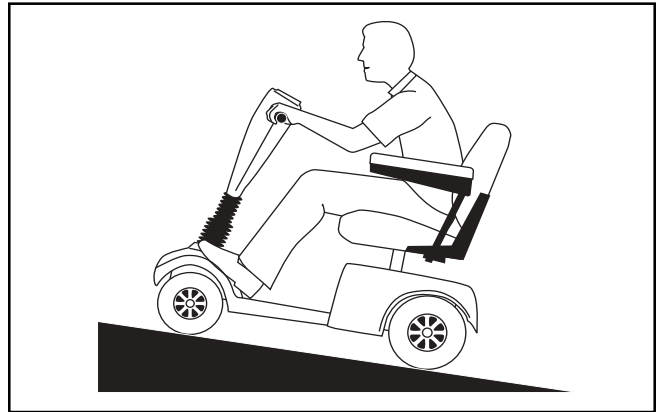

Figure 2A. Increased Stability Driving Position

### CORNERING INFORMATION

Excessively high cornering speeds can create the possibility of tipping. Factors which affect the possibility of tipping include, but are not limited to, cornering speed, steering angle (how sharply you are turning), uneven road surfaces, inclined road surfaces, riding from an area of low traction to an area of high traction (such as passing from a grassy area to a paved area – especially at high speed while turning), and abrupt directional changes. High cornering speeds are not recommended. If you feel that you may tip over in a corner, reduce your speed and steering angle (i.e., lessen the sharpness of the turn) to prevent your scooter from tipping.



**WARNING!** When cornering sharply, reduce your speed. When using your scooter at higher speeds, do not corner sharply. This greatly reduces the possibility of a tip or fall. To avoid personal injury or property damage, always exercise common sense when cornering.

### BRAKING INFORMATION

Your scooter is equipped with these powerful brake systems:

- **Regenerative:** Uses electricity to rapidly slow the vehicle when the throttle control lever returns to the center/stop position.
- **Disc Park Brake:** Activates mechanically after regenerative braking slows the vehicle to near stop, or when power is removed from the system for any reason.

## II. SAFETY

### OUTDOOR DRIVING SURFACES

Your scooter is designed to provide optimum stability under normal driving conditions—dry, level surfaces composed of concrete, blacktop, or asphalt. However, Pride recognizes that there will be times when you will encounter other surface types. For this reason, your scooter is designed to perform admirably on packed soil, grass, and gravel. Feel free to use your scooter safely on lawns and in park areas.

- Reduce your scooter's speed when driving on uneven terrain and/or soft surfaces.
- Avoid tall grass that can become tangled in the running gear.
- Avoid loosely packed gravel and sand.
- If you feel unsure about a driving surface, avoid that surface.

### PUBLIC STREETS AND ROADWAYS



**WARNING!** You should not operate your scooter on public streets and roadways. Be aware that it may be difficult for traffic to see you when you are seated on your scooter. Obey all local pedestrian traffic rules. Wait until your path is clear of traffic, and then proceed with extreme caution.

**NOTE:** *Safety accessories like fluorescent flags are available to order from your authorized Pride Provider.*

### STATIONARY OBSTACLES (STEPS, CURBS, ETC.)

**WARNING!** Do not drive near raised surfaces, unprotected ledges, and/or drop-offs (curbs, porches, stairs, etc.).

**WARNING!** Do not attempt to have your scooter climb or descend an obstacle that is inordinately high. Serious personal injury and/or damage may result.



**WARNING!** Do not attempt to have your scooter proceed backward down any step, curb, or other obstacle. This may cause the scooter to tip and cause personal injury.

**WARNING!** Be sure your scooter is traveling perpendicular to any curb you may be required to ascend or descend. See figures 3 and 3A.

**WARNING!** Do not attempt to negotiate a curb that has a height greater than 2 in.

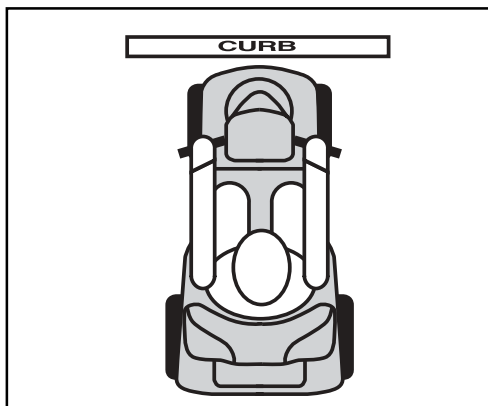

Figure 3. Correct Curb Approach

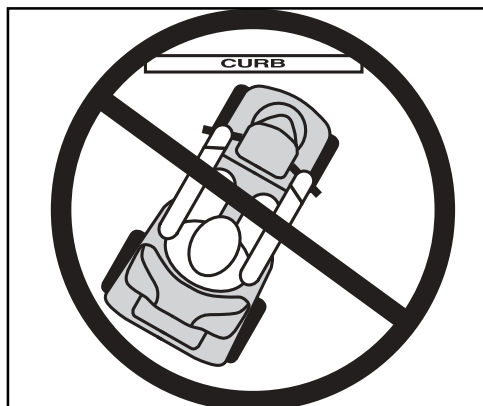

Figure 3A. Incorrect Curb Approach

# II. SAFETY

## INCLEMENT WEATHER PRECAUTIONS

WARNING! Pride recommends that you do not operate your scooter in icy or slippery conditions or on salted surfaces (i.e., walks or roads). Such use may result in an accident, personal injury, or adversely affect the performance and safety of your scooter.



WARNING! Do not operate or store your scooter where it may be exposed to inclement weather conditions such as rain, snow, mist, and below freezing temperatures (such as storage on an outside car/van lift). Attempting to operate the scooter in such conditions can damage the electronics and potentially result in loss of control.

## FREEWHEEL MODE

Your scooter is equipped with a manual freewheel lever that, when pushed forward, allows the scooter to be pushed. For more information about how to place your scooter into and out of freewheel mode, see V. “Your Scooter.”

WARNING! When your scooter is in freewheel mode, the braking system is disengaged.



- Disengage the drive motors only on a level surface.
- Ensure the key is removed from the key switch.
- Stand behind the scooter to engage or disengage freewheel mode. Never sit on a scooter to do this.
- After you have finished pushing your scooter, always return it to the drive mode to lock the brakes.

Failure to heed the above could result in personal injury and/or damage to your scooter.

An added feature built into the scooter is “**push-too-fast**” protection which safeguards the scooter against gaining excessive speed while in freewheel mode.

“Push-too-fast” operates differently depending on which of two conditions exists:

- If the key is removed from the key switch while in freewheel mode, the scooter’s controller activates regenerative braking when the scooter is pushed faster than a maximum threshold which has been preprogrammed. In this case, the controller is acting as a speed governor.
- If the key is inserted into the key switch while in freewheel mode, you will encounter considerable resistance at any speed. This prevents the scooter from gaining unwanted momentum should the manual freewheel lever inadvertently be released while driving the scooter.

## STAIRS AND ESCALATORS

Scooters are not designed to travel up or down stairs or escalators. Always use an elevator.



WARNING! Do not use your scooter to negotiate steps or escalators. You may cause injury to yourself and to others and/or damage your scooter.

## II. SAFETY

### DOORS

- Determine if the door opens toward or away from you.
- Use your hand to turn the knob or push the handle or push-bar.
- Drive your scooter gently and slowly forward to push the door open. Or drive your scooter gently and slowly backwards to pull the door open.

### ELEVATORS

Modern elevators have a door edge safety mechanism that, when pushed, reopens the door(s).

- If you are in the doorway of a elevator when the door(s) begin to close, push on the rubber door edge or allow the rubber door edge to contact the scooter and the door will reopen.
- Use care that pocketbooks, packages, or scooter accessories do not become caught in elevator doors.

### LIFT/ELEVATION PRODUCTS

If you will be traveling with your scooter, you may find it necessary to use a lift/elevation product to aid in transportation. Pride recommends that you closely review the instructions, specifications, and safety information set forth by the manufacturer of the lift/elevation product before using that product.

### BATTERIES

In addition to following the warnings below, be sure to comply with all other battery handling information.

WARNING! Scooter batteries are heavy (refer to specifications table). Lifting weight beyond your capacity could result in personal injury. If necessary, get someone physically able to lift the scooter batteries for you.

WARNING! Battery posts, terminals, and related accessories contain lead and lead compounds. Wash hands after handling.



WARNING! Always protect the batteries from freezing and never charge a frozen battery. Charging a frozen battery may result in personal injury and/or damage to the battery.

WARNING! RED (+) cables must be connected to positive (+) battery terminals/posts. BLACK (-) cables must be connected to negative (-) battery terminals/posts. Failure to connect your battery cables and harnesses in the proper manner may result in personal injury and/or damage to your scooter. REPLACE cables immediately if damaged.

### BATTERY DISPOSAL AND RECYCLING

If you encounter a damaged or cracked battery, immediately enclose it in a plastic bag and call your authorized Pride Provider for instructions on disposal. Your authorized Pride Provider will also have the necessary information on battery recycling, which is our recommended course of action.

## II. SAFETY

### MOTOR VEHICLE TRANSPORT

Currently, there are no standards approved for tie-down systems in a moving vehicle of any type to transport a person while seated in a scooter.

Although your scooter may be equipped with a positioning belt, this belt is not designed to provide proper restraint during motor vehicle transport. Anyone traveling in a motor vehicle should be properly secured in the motor vehicle seat with safety belts fastened securely.

**WARNING!** Do not sit on your scooter while it is in a moving vehicle. Personal injury and/or property damage may result.



**WARNING!** Always be sure your scooter and its batteries are properly secured when it is being transported. Failure to do so may result in personal injury and/or damage to your scooter.

### PREVENTING UNINTENDED MOVEMENT



**WARNING!** If you anticipate being seated in a stationary position for an extended period of time, turn off the power. This will prevent unexpected motion from inadvertent throttle control lever contact. Failure to do so may result in personal injury.

### GETTING ONTO AND OFF OF YOUR SCOOTER

Getting onto and off of your scooter requires a good sense of balance. Please observe the following safety tips when getting onto and off of your scooter:

- Remove the key from the key switch.
- Ensure that your scooter is not in freewheel mode. See V. “Your Scooter.”
- Make certain that the seat is locked into place.
- The armrests of the seat can be flipped up to make getting onto and off of the scooter easier.

**WARNING!** When driving on level ground, position yourself as far back as possible in the scooter seat to prevent the scooter from tipping and causing injury.



**WARNING!** Avoid using your armrests for weight bearing purposes. Such use may cause the scooter to tip and cause personal injury.

**WARNING!** Avoid putting all of your weight on the floorboard. Such use may cause the scooter to tip and cause personal injury.

### REACHING AND BENDING

Avoid reaching or bending while driving your scooter. When reaching, bending, or leaning while seated on your scooter, it is important to maintain a stable center of gravity and keep the scooter from tipping. Pride recommends that the scooter user determine his/her personal limitations and practice bending and reaching in the presence of a qualified healthcare professional.



**WARNING!** Do not bend, lean, or reach for objects if you have to pick them up from the floor. Movements such as these may change your center of gravity and the weight distribution of the scooter and cause your scooter to tip, possibly resulting in personal injury.

**WARNING!** Prevent personal injury, keep your hands away from the tires when driving. Be aware that loose fitting clothing can become caught in drive tires.

## II. SAFETY

### POSITIONING BELTS

Your authorized Pride Provider, therapist(s), and other healthcare professionals are responsible for determining your requirement for a positioning belt in order to operate your scooter safely.



WARNING! If you require a positioning belt to safely operate your scooter, make sure it is fastened securely. Serious personal injury may result if you fall from the scooter.

### PRESCRIPTION DRUGS/PHYSICAL LIMITATIONS

The scooter user must exercise care and common sense when operating his/her scooter. This includes awareness of safety issues when taking prescribed or over-the-counter drugs or when the user has specific physical limitations.



WARNING! Consult your physician if you are taking prescribed or over-the-counter medication or if you have certain physical limitations. Some medications and limitations may impair your ability to operate your scooter in a safe manner.

### ALCOHOL

The scooter user must exercise care and common sense when operating his/her scooter. This includes awareness of safety issues while under the influence of alcohol.



WARNING! Do not operate your scooter while you are under the influence of alcohol, as this may impair your ability to drive safely.

# III. EMI/RFI

## ELECTROMAGNETIC AND RADIO FREQUENCY INTERFERENCE (EMI/RFI)



WARNING! Laboratory tests have shown that electromagnetic and radio frequency waves can have an adverse affect on the performance of electrically-powered mobility vehicles.

Electromagnetic and Radio Frequency Interference can come from sources such as cellular phones, mobile two-way radios (such as walkie-talkies), radio stations, TV stations, amateur radio (HAM) transmitters, wireless computer links, microwave signals, paging transmitters and medium-range mobile transceivers used by emergency vehicles. In some cases, these waves can cause unintended movement or damage to the control system. Every electrically-powered mobility vehicle has an immunity (or resistance) to EMI. The higher the immunity level, the greater the protection against EMI. This product has been tested and has passed at an immunity level of 20 V/M.



WARNING! Be aware that cell phones, two-way radios, laptops, and other types of radio transmitters may cause unintended movement of your electrically-powered mobility vehicle due to EMI. Exercise caution when using any of these items while operating your mobility vehicle and avoid coming into close proximity of radio and TV stations.

WARNING! The addition of accessories or components to the electrically-powered mobility vehicle can increase the susceptibility of the vehicle to EMI. Do not modify your scooter in any way not authorised by Pride.

WARNING! The electrically-powered mobility vehicle itself can disturb the performance of other electrical devices located nearby, such as alarm systems.

***NOTE: For further information on EMI/RFI, visit the Resource Center on [www.pridemobility.com](http://www.pridemobility.com). If unintended motion or brake release occurs, turn your scooter off as soon as it is safe to do so. Contact your authorized Pride Provider to report the incident.***



# IV. SPECIFICATIONS

<b>Model Numbers</b>	3-wheel: SC63 4-wheel: SC64
<b>Available Colors</b>	Revo Red, Revo Blue
<b>Overall Length</b>	3-wheel: 43.25 in. 4-wheel: 44.75 in.
<b>Overall Width</b>	21.5 in.
<b>Total weight including Batteries</b>	3-wheel: 168.5 lbs. 4-wheel: 187 lbs.
<b>Total Weight Without Battery Packs</b>	3-wheel: 106.5 lbs. 4-wheel: 125 lbs.
<b>Heaviest Piece When Disassembled</b>	3-wheel: rear section 48 lbs. 4-wheel: front section 51.5 lbs.
<b>Turning Radius</b>	3-wheel: 38 in. 4-wheel: 50 in.
<b>Speed (maximum)</b>	Variable up to 4.5 mph
<b>Range Per Charge*</b>	(35 AH batteries) Up to 20 miles
<b>Ground Clearance</b>	2.25 in.
<b>Weight Capacity</b>	300 lbs. Maximum
<b>Standard Seating</b>	Type: Foldable molded plastic Material: Black vinyl with Charcoal fabric center Dimensions: 17 in. width 16 in. depth 12 in. height
<b>Drive System</b>	Rear-wheel drive, sealed transaxle, with 24 volt, DC motor
<b>Dual Braking System</b>	Electronic, regenerative, and electromechanical
<b>Wheels</b>	3-wheel front: molded plastic 3-wheel rear: aluminum mags 4-wheel front: aluminum mags 4-wheel rear: aluminum mags
<b>Tires</b>	Type: solid, flat free Front: 2 in. x 8 in. Rear: 3 in. x 9 in.
<b>Battery Requirements</b>	Type: (2) 12-volt, deep cycle (AGM or Gel-Cell type recommended) Size: U1 (35 AH) Battery pack weight: 31 lbs. each
<b>Battery Charger</b>	Off-board charger

\* Varies with user weight, terrain type, battery charge, battery condition, and tire condition

# IV. SPECIFICATIONS

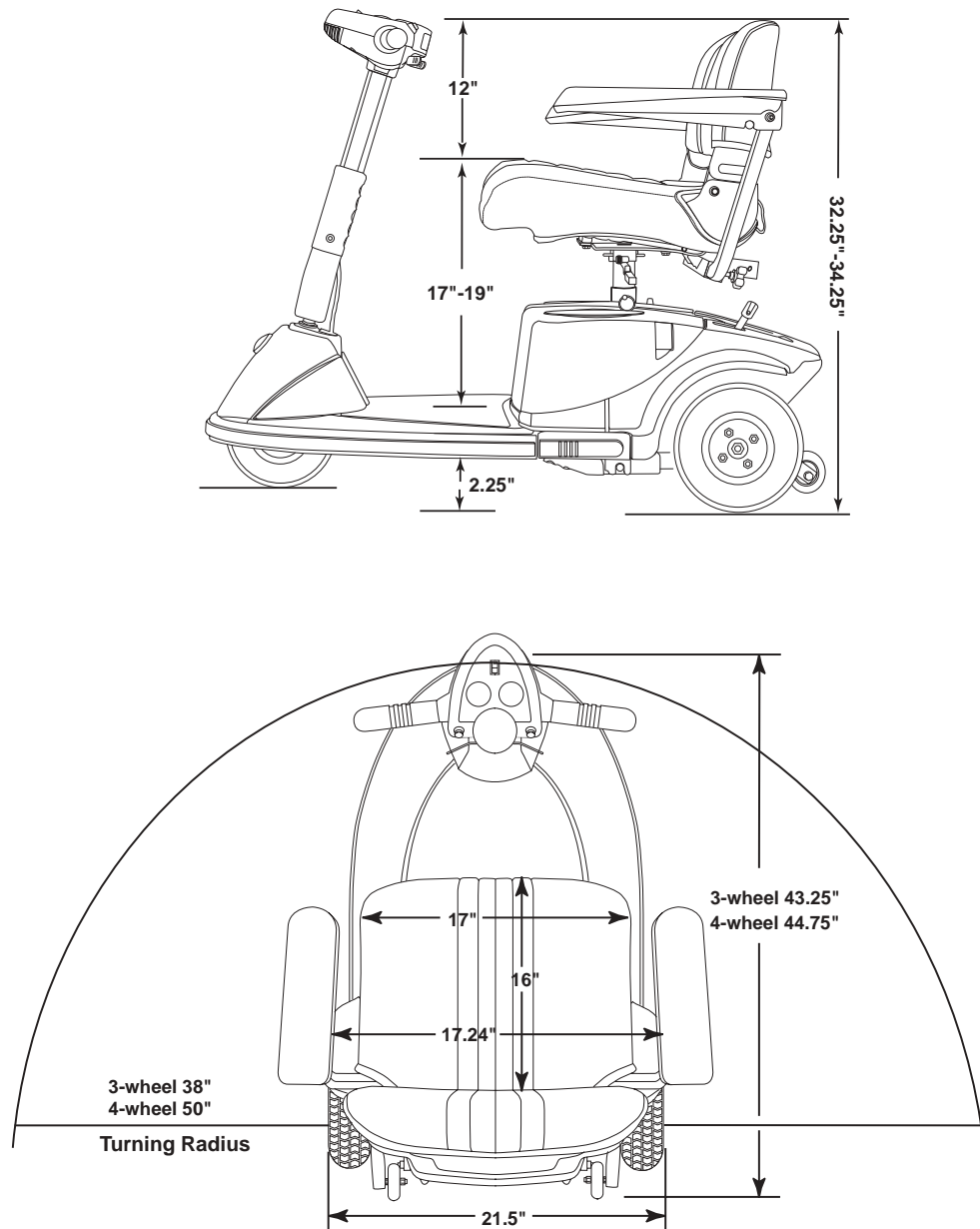

Figure 4. Scooter Dimensions

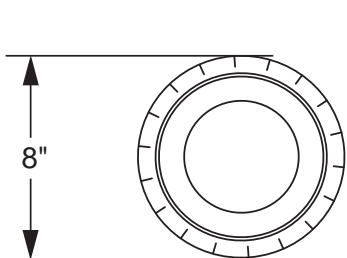

Figure 4A. Front Tire Dimensions

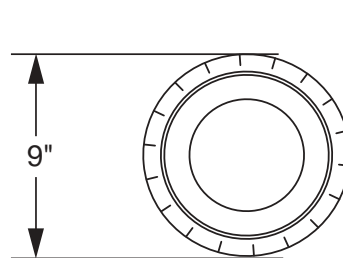
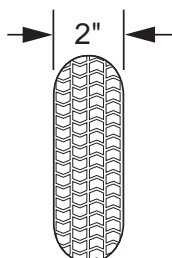
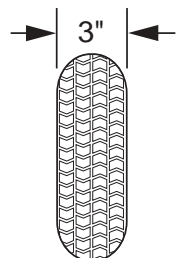

Figure 4B. Rear Tire Dimensions



# V. YOUR SCOOTER

## TILLER CONSOLE

The tiller console houses all controls needed to drive your scooter, including the speed adjustment dial, key switch, throttle control lever, battery condition meter, running lights switch, and horn buttons. See figure 5.



**WARNING!** Do not expose the tiller console to moisture. In the event that the tiller console does become exposed to moisture, do not attempt to operate your scooter until the tiller console has dried thoroughly.

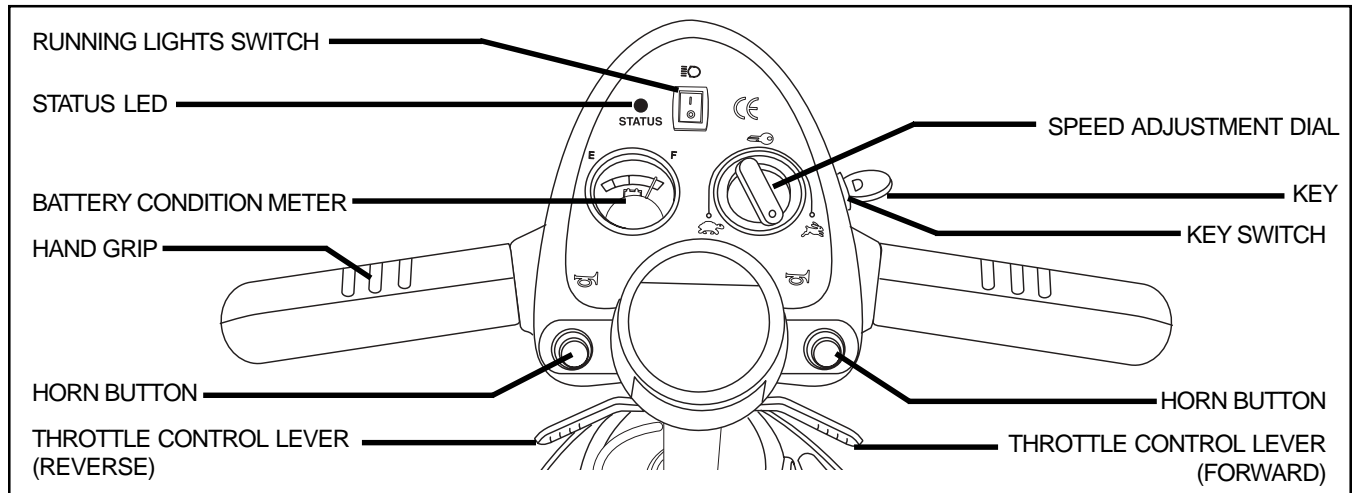

Figure 5. Tiller Console

### Key Switch

- Insert the key into the key switch and turn it clockwise to power up (turn on) your scooter.
- Turn the key counterclockwise to power down (turn off) your scooter.

Although the key can be left in the key switch when the scooter is powered down, we recommend removing it to prevent unauthorized use of your scooter.



**WARNING!** If the key is moved to the “off” position while your scooter is in motion, the electronic brakes engage and your scooter will come to an abrupt stop!

### Throttle Control Lever

This lever allows you to control the forward speed and the reverse speed of your scooter up to the maximum speed you preset with the speed adjustment dial.

- Place your right hand on the right handgrip and your left hand on the left handgrip.
- Use your right thumb to push the right side of the lever to disengage your scooter’s brakes and move forward.
- Release the lever and allow your scooter to come to a complete stop before pushing the other side of the lever to move in reverse.
- When the throttle is completely released, it automatically returns to the center “stop” position and engages your scooter’s brakes.

### Running Lights Switch

This button controls your scooter’s front and rear running lights.

- Toggle the switch forward to turn on the running lights.
- Toggle the switch back to turn off the running lights.

# V. YOUR SCOOTER

## Horn Button

The key must be fully inserted into the key switch for the horn to be operational.

- This button activates a warning horn.
- Do not hesitate to use the warning horn when doing so may prevent accident or injury.

## Status LED

The status LED will alert you to electrical problems that may occur with the scooter. The LED remains constantly lit while your scooter is on. If the scooter develops an electrical problem, the status LED will flash a code. See X. “Basic Troubleshooting” for flash codes. If the status LED flashes a code other than a code listed, contact your authorized Pride Provider.

## Battery Condition Meter

The battery condition meter indicates the approximate strength of your batteries while the scooter is on.

## Speed Adjustment Dial

This dial allows you to select a maximum speed.

- The picture of the tortoise represents the slowest speed setting.
- The picture of the hare represents the fastest speed setting.

## REAR SECTION

The manual freewheel lever, anti-tip wheels, battery packs, and the motor/transaxle assembly (not shown) are located on the rear section of your scooter. See figure 6.

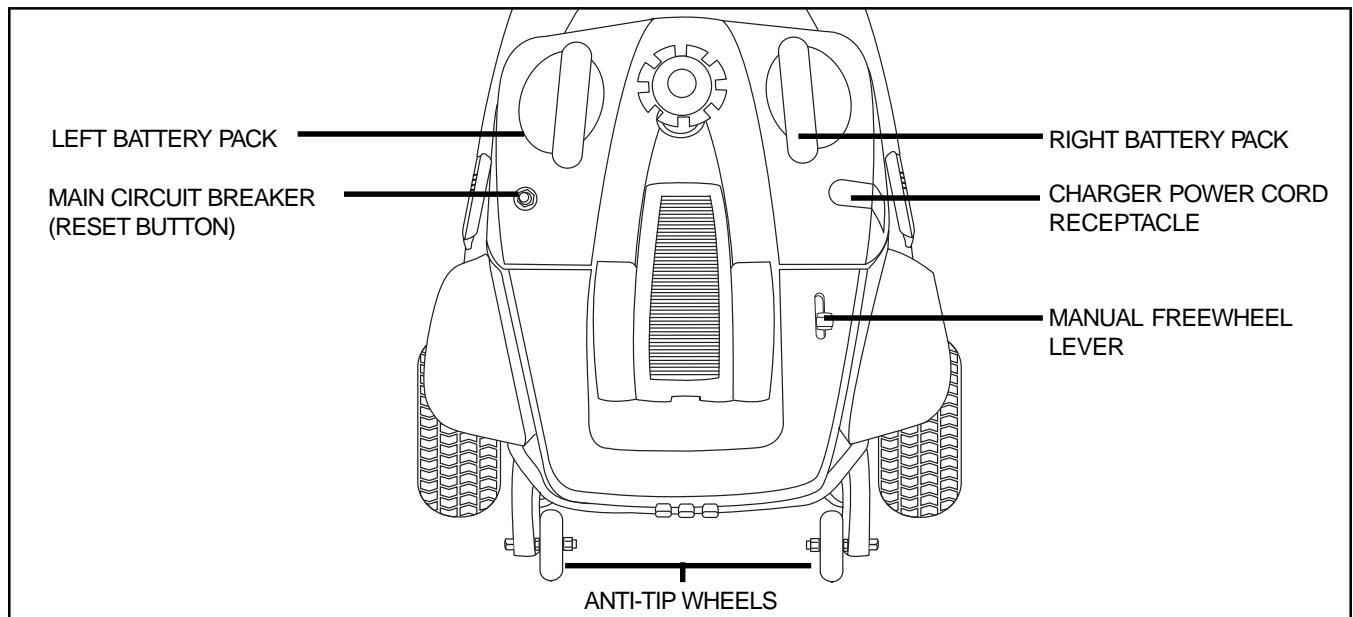

Figure 6. Rear Section

## Anti-Tip Wheels

The anti-tip wheels are an integral and important safety feature of your scooter. Do not, under any circumstances, remove the anti-tip wheels from your scooter.



**WARNING!** Do not remove the anti-tip wheels or modify your scooter in any way that is not authorized by Pride.

# V. YOUR SCOOTER

## Battery Packs

The scooter is equipped with two easy-to-remove battery packs. The packs contain the charger power cord receptacle, the main circuit breaker (reset button), and the batteries. The batteries store electrical energy that powers your scooter. See VI. “Batteries and Charging.”

## Charger Power Cord Receptacle

The charger power cord plugs into your scooter’s battery charger by means of the charger power cord receptacle.

## Main Circuit Breaker (Reset Button)

When the voltage in your scooter’s batteries becomes low or the scooter is heavily strained because of excessive loads or steep inclines, the main circuit breaker may trip to protect the motor and electronics from damage.

- The main circuit breaker reset button pops out when the breaker trips.
- When the breaker trips, the entire electrical system of your scooter shuts down.
- Allow a minute or two for your scooter’s electronics to “rest.”
- Push in the reset button to reset the main circuit breaker.
- If the main circuit breaker trips frequently, you may need to charge your batteries more often. You may also need to have your authorized Pride Provider perform a load test on your scooter’s batteries.

## Manual Freewheel Lever

Whenever you need or want to push your scooter for short distances, you can put it in freewheel mode.

- The manual freewheel lever is located at the top right of the rear section.
- Push forward on the manual freewheel lever to disable the drive system and the brake system.
- You may now push your scooter.
- Push the manual freewheel lever backward to reengage the drive and the brake systems; this takes your scooter out of freewheel mode.

WARNING! When your scooter is in freewheel mode, the braking system is disengaged.

- Disengage the drive motors only on a level surface.
- Ensure the key is removed from the key switch.
- Stand behind the scooter to engage or disengage freewheel mode. Never sit on a scooter to do this.
- After you have finished pushing your scooter, always return it to the drive mode to lock the brakes.



Failure to heed the above could result in personal injury and/or damage to your scooter.

## Motor/Transaxle Assembly (Not Shown)

The motor/transaxle assembly is an electromechanical unit that converts electrical energy from your scooter’s batteries into the controlled mechanical energy that drives the scooter’s wheels.

## VI. BATTERIES AND CHARGING

Your scooter is equipped with two sealed, maintenance free batteries.

- Charge the batteries prior to using your scooter for the first time.
- Keep the batteries fully charged to keep your scooter running smoothly.

### READING YOUR BATTERY VOLTAGE

The battery condition meter on the tiller console uses a color code to indicate the approximate strength of your batteries. Green indicates fully charged batteries, yellow a draining charge, and red indicates that an immediate recharge is necessary. See figure 7.

To check the battery strength during charging, you must first unplug the charger power cord and power up your scooter by inserting the key into the key switch and turning it to the on position.

**NOTE:** *To ensure the highest accuracy, the battery condition meter should be checked while operating your scooter at full speed on a level surface.*

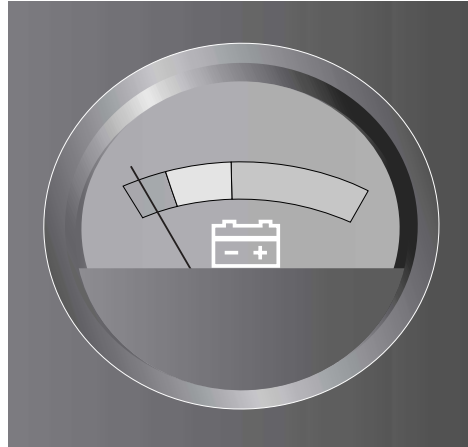

Figure 7. Battery Condition Meter

### OFF-BOARD BATTERY CHARGER VOLTAGE SWITCH

The offboard charger supplied with your scooter is equipped with a 115/230 voltage switch. The voltage switch is preset at “115V” and is intended to be used with a standard 110/115V electrical outlet. Ensure this is the case before attempting to insert the charger plug into the electrical outlet. If the setting is incorrect, the charger will not function properly. Slide the switch to the prescribed position. See Figure 7A.

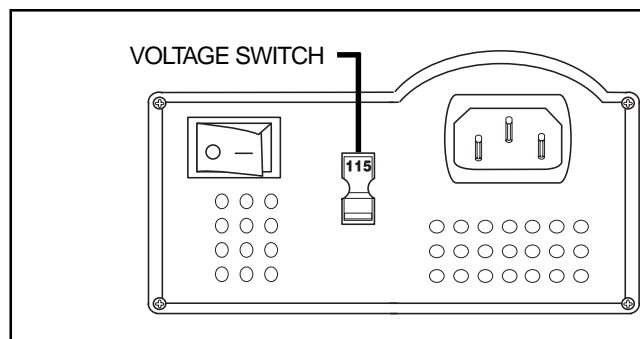

Figure 7A. Voltage Switch

# VI. BATTERIES AND CHARGING

## CHARGING THE BATTERIES ON THE SCOOTER

WARNING! Never use an extension cord to plug in your battery charger. Plug the charger directly into a properly wired standard wall outlet.



WARNING! Removal of the grounding prong can create an electrical hazard. If necessary, properly install an approved 3-prong adapter to an electrical outlet having 2-pronged plug access. Failure to heed could result in personal injury and or property damage.

### Follow these easy steps to charge your batteries safely:

1. Position your scooter close to a standard wall outlet.
2. Remove the key from the key switch.
3. Make certain that the manual freewheel lever is in the drive (pushed back) position.
4. Remove the charger power cord receptacle cover from the charger power cord receptacle and plug the 3-pin charger power cord into the receptacle. See figure 8.
5. Make sure the battery charger switch is in the “off” position. See figure 8B.
6. Extend the charger power cord and plug it into the wall outlet.
7. Turn the charger on. See figure 8B. It is recommended that you charge your batteries for 8 to 14 hours.
8. When the batteries are fully charged, turn the charger off and unplug the charger power cord from the wall outlet and then from the charger power cord receptacle.
9. Replace the charger power cord receptacle cover.

**NOTE: There is a charger inhibit function on your scooter. The scooter will not run and the battery condition meter will not operate if the charger power cord is not disconnected from the battery pack.**

## CHARGING THE BATTERIES OFF OF THE SCOOTER

Removing the battery packs and charging them off the scooter is convenient should you want to leave the scooter in your vehicle.

To charge the batteries off of the scooter:

1. Remove the battery packs from the scooter and place them on a flat, dry surface in exactly the same positions as they are on the scooter.
2. Follow steps 4-9 from above.
3. Reinstall the batteries onto the scooter. See IX, “Assembly and Disassembly” for information on how to remove and position the battery packs.

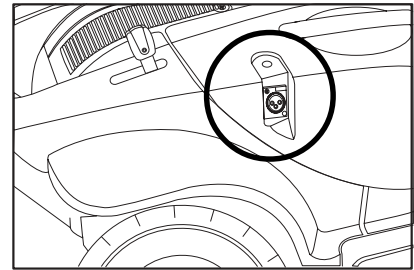

Figure 8. Charger Power Cord Receptacle

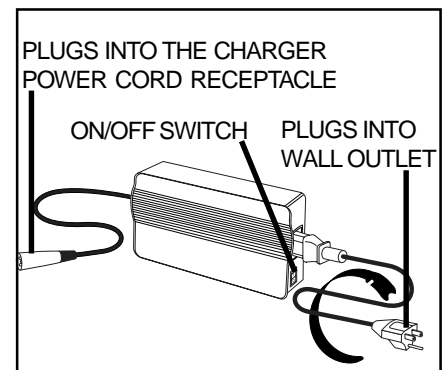

Figure 8A. Off-Board Charger

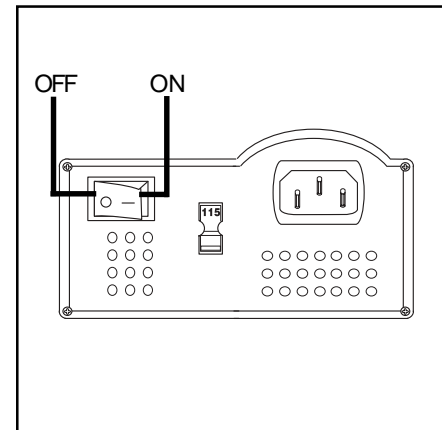

Figure 8B. Charger On/Off Switch

# VI. BATTERIES AND CHARGING

## FREQUENTLY ASKED QUESTIONS (FAQS)

### How does the charger work?

When your scooter's battery voltage is low the charger works harder, sending more electrical current to the batteries to bring up their charge. As the voltage approaches full charge, the charger sends less and less electrical current to the batteries. When the batteries are fully charged, the current sent by the charger is at nearly zero amperage. Therefore, when the charger is plugged in, it maintains the charge on your scooter's batteries, but does not overcharge them. We do not recommend that you charge your scooter's batteries for more than 24 consecutive hours.

### What if my scooter's batteries won't charge?

- Ensure that both ends of the charger power cord are inserted fully.
- Ensure that both battery packs are seated into the battery wells properly.
- Ensure that the charger is turned on at the toggle switch located on the side of the off-board charger.
- Check the charger fuse located inside the right battery pack. The fuse is attached to the wire leading from the charger power cord receptacle.

### How often must I charge the batteries?

Two major factors must be considered when deciding how often to charge your scooter's batteries:

- All day scooter use on a daily basis.
- Infrequent or sporadic scooter use.

With these considerations in mind, you can determine how often and for how long you should charge your scooter's batteries. We designed the charger so that it will not overcharge your scooter's batteries. However, you may encounter some problems if you do not charge your batteries often enough and if you do not charge them on a regular basis. Following the guidelines below will provide safe and reliable battery operation and charging.

- If you use your scooter daily, charge its batteries as soon as you finish using it for the day. Your scooter will be ready each morning to give you a full day of service. We recommend that you charge your scooter's batteries for 8 to 14 hours after daily use.
- If you use your scooter once a week or less, charge its batteries at least once a week for 12 to 14 hours at a time.
- Keep your scooter's batteries fully charged.
- Avoid deeply discharging your scooter's batteries.
- Do not charge your scooter's batteries for more than 24 consecutive hours.

### How can I get maximum range or distance per charge?

Rarely will you have ideal driving conditions—smooth, flat, hard driving surfaces with no wind or curves. Often, you will face hills, pavement cracks, uneven and loosely packed surfaces, curves, and wind, all of which affect the distance or running time per battery charge. Below are a few suggestions for obtaining the maximum range per battery charge.

- Always fully charge your scooter's batteries prior to daily use.
- If equipped with pneumatic tires, maintain **30-35 psi** in each tire.
- Plan your route ahead to avoid as many hills, cracked, broken, or soft surfaces as possible.
- Limit your baggage weight to essential items.
- Try to maintain an even speed while your scooter is in motion.
- Avoid stop-and-go driving.



## VI. BATTERIES AND CHARGING

### What type and size of battery should I use?

We recommend deep-cycle batteries that are sealed and maintenance free. Both AGM and Gel-Cell are deep-cycle batteries that are similar in performance. Do not use wet-cell batteries, which have removable caps.



**WARNING!** Corrosive chemicals are contained in batteries. Use only AGM or Gel-Cell batteries to reduce the risk of leakage or explosive conditions.

**NOTE: Sealed batteries are not serviceable. Do not remove the caps.**

To change a battery in your scooter:



**WARNING!** Battery posts, terminals, and related accessories contain lead and lead compounds. Wash hands after handling.

1. Remove the seat.
2. Remove the battery packs from the scooter. Always remove the left side battery pack first. See IX. “Disassembly and Assembly.”
3. Remove the 7 screws from the underside of the pack.
4. Arrange the pack so the handle is facing up and slowly remove the cover and situate it as shown in figure 9.
5. Disconnect the battery cables from the battery terminals by removing the nut and bolt from each terminal.
6. Remove the old battery.
7. Place a new battery into the battery pack.
8. Connect the red battery cable to the positive (+) battery terminal.
9. Connect the black battery cable to the negative (-) battery terminal.
10. Replace battery pack cover.
11. Reinstall the 7 screws that hold the pack together and tighten.
12. Reinstall the battery packs onto the scooter and close the battery locks. Always reinstall the right side battery pack first.
13. Reinstall the seat.

**NOTE: If you encounter a damaged or cracked battery, immediately enclose it in a plastic bag and call your authorized Pride Provider for instructions on disposal. Your authorized Pride Provider will also have the necessary information on battery recycling, which is our recommended course of action.**

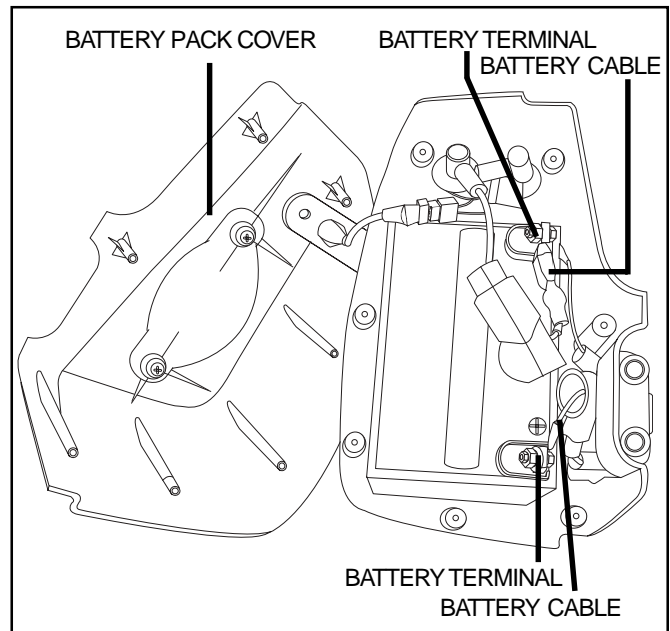

Figure 9. Battery Replacement

## VI. BATTERIES AND CHARGING

### **Why do my new batteries seem weak?**

Deep-cycle batteries employ a different chemical technology than that used in car batteries, nickel-cadmium batteries (nicads), and other common battery types. Deep-cycle batteries are specifically designed to provide power, drain down their charge, and then accept a relatively quick recharge.

We work closely with our battery manufacturer to provide batteries that best suit your scooter's specific electrical demands. Fresh batteries arrive daily at Pride and are shipped fully charged to our customers. During shipping, the batteries may encounter temperature extremes that can influence their initial performance. Heat diminishes the charge on the battery; cold slows the available power and extends the time needed to recharge the battery.

It may take a few days for the temperature of your scooter's batteries to stabilize and adjust to their new room or ambient temperature.

More importantly, it takes a few charging cycles (partial draining followed by full recharging) to establish the critical chemical balance that is essential to a deep-cycle battery's peak performance and long life.

Follow these steps to properly break in your scooter's new batteries for maximum efficiency and service life.

1. Fully recharge any new battery prior to its initial use. This charging cycle brings the battery up to about 88% of its peak performance level.
2. Operate your new scooter in familiar and safe areas. Drive slowly at first, and do not travel too far from your home or familiar surroundings until you have become accustomed to your scooter's controls and have properly broken in your scooter's batteries.
3. Fully recharge the batteries. They should be at over 90% of their peak performance level.
4. Operate your scooter again.
5. Fully recharge the batteries again.
6. After four or five charging cycles, the batteries are able to receive a charge of 100% of their peak performance level and are able to last for an extended period of time.

### **What about public transportation?**

If you intend to use public transportation with your scooter, you must contact the transportation provider in advance to determine their specific requirements.

# VII. OPERATION

## BEFORE GETTING ONTO YOUR SCOOTER

- Have you fully charged the batteries? See VI. “Batteries and Charging.”
- Is the manual freewheel lever in the drive (pulled back) position? Never leave the manual freewheel lever pushed forward unless you are manually pushing your scooter.
- Is the tiller lock knob in the unlocked position and can you turn the tiller from side to side freely?

## GETTING ONTO YOUR SCOOTER



WARNING! Before getting onto your scooter always check that the tiller lock is in the unlocked position. Attempting to ride your scooter with the tiller lock in the locked position can result in personal injury.

WARNING! Never attempt to get onto or off of your scooter without first removing the key from the key switch. This will prevent the scooter from moving if accidental throttle control lever contact is made.

1. Make certain that the key is removed from the key switch.
2. Stand at the side of your scooter.
3. Disengage the seat lock lever and rotate the seat until it is facing you.
4. Make certain that the seat is locked securely in position.
5. Position yourself comfortably and securely in the seat.
6. Disengage the seat lock lever and rotate the seat until you are facing forward.
7. Make certain that the seat is locked securely in position.
8. Make certain that your feet are safely on the floorboard.

## PRE-RIDE ADJUSTMENTS AND CHECKS

- Is the seat at the proper height? See VIII. “Comfort Adjustments.”
- Is the seat locked securely in place?
- Is the tiller at a comfortable setting and locked securely in place? See VIII. “Comfort Adjustments.”
- Is the key fully inserted into the key switch ?
- Does the scooter’s horn work properly?
- Is your proposed path clear of people, pets, and obstacles?
- Have you planned your route to avoid adverse terrain and as many inclines as possible?

## OPERATING YOUR SCOOTER

WARNING! The following can adversely affect steering and stability while operating your scooter:



- Holding onto or attaching a leash to walk your pet.
- Carrying passengers (including pets).
- Hanging any article from the tiller.
- Towing or being pushed by another motorized vehicle.

Such practices could cause loss of control and/or tipping, resulting in personal injury and/or damage to your scooter.

Keep both hands on the tiller and your feet on the floorboard at all times while operating your scooter. This driving position gives you the most control over your vehicle.

- Set the speed adjustment dial to your desired speed.
- Press your thumb against the appropriate throttle control lever.

## VII. OPERATION

- The electromechanical disc park brake automatically disengages and the scooter accelerates smoothly to the speed you preselected with the speed adjustment dial.
- Pull on the left handgrip to steer your scooter to the left.
- Pull on the right handgrip to steer your scooter to the right.
- Move the tiller to the center position to drive straight ahead.
- To stop, slowly release the throttle control lever. The electronic brakes will automatically engage when your scooter comes to a stop.

**NOTE:** *Your scooter's reverse speed is slower than that of the forward speed you preset with the speed adjustment dial.*

### GETTING OFF OF YOUR SCOOTER

1. Bring your scooter to a complete stop.
2. Remove the key from the key switch.
3. Disengage the seat lock lever and rotate the seat until you are facing toward the side of your scooter.
4. Make certain that the seat is locked securely in position.
5. Carefully and safely get out of the seat and stand to the side of your scooter.
6. You can leave the seat facing to the side to facilitate boarding your scooter next time.

### POWER DOWN TIMER FEATURE

Your scooter is equipped with an energy saving automatic power down timer feature designed to preserve your scooter's battery life. If you mistakenly leave the key in the key switch but do not use your scooter for approximately 20 minutes, the scooter's controller shuts down automatically. Although the controller is shut down, power will still be supplied to the scooter's lighting system.

If the power down timer feature takes effect, perform the following steps to resume normal operation.

1. Remove the key from the key switch.
2. Reinsert the key and power up your scooter.

# VIII. COMFORT ADJUSTMENTS

## TILLER ANGLE ADJUSTMENT



**WARNING!** Remove the key from the key switch before adjusting the tiller or the seat. Never attempt to adjust the tiller or the seat while the scooter is in motion.

Your scooter is equipped with a pivoting tiller that allows adjustment to several positions from the scooter deck to the farthest forward stop. See figure 10.

1. Turn the tiller angle adjustment knob counterclockwise to loosen the tiller.
2. Move the tiller to a comfortable position.
3. Turn the tiller angle adjustment knob clockwise to secure the tiller in position.

**NOTE:** *In order to lower the tiller to the scooter deck, you must first remove the seat and both battery packs. See IX. “Disassembly and Assembly.”*

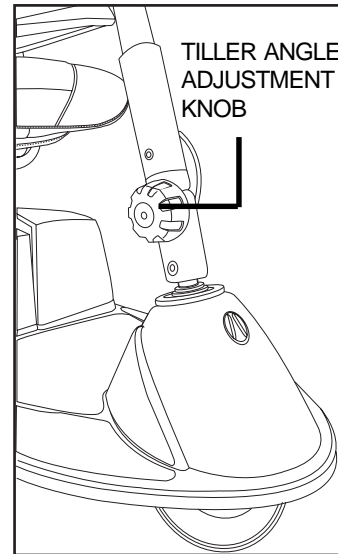

Figure 10. Tiller Angle Adjustment Knob

## SEAT ROTATION

The seat lock lever locks the seat in one of four positions.

1. Pull up on the seat lock lever to unlock the seat. See figure 11.
2. Rotate the seat to the desired position.
3. Release the seat lock lever to lock the seat securely in place.

## ARMREST WIDTH ADJUSTMENT

The armrest width can be adjusted inward or outward.

1. Loosen the armrest adjustment knobs at the back of the seat frame. See figure 11.
2. Slide the armrests in or out to the desired width.
3. Tighten the armrest adjustment knobs as required.

The armrests can also pivot upward to aid in getting onto and off of your scooter.

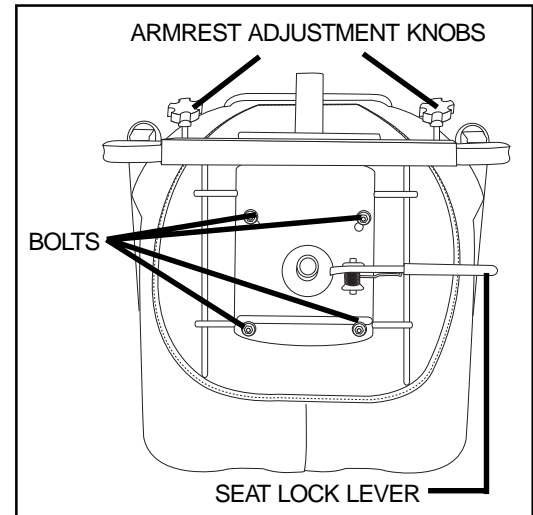

Figure 11. Seat Adjustments

## VIII. COMFORT ADJUSTMENTS

### FRONT-TO-BACK SEAT ADJUSTMENT

You can reposition the scooter's seat forward or rearward to one of three settings, to adjust the distance between the seat and the tiller.

1. Remove the seat from your scooter. Refer to IX. "Disassembly and Assembly."
2. Remove the four bolts that fasten the seat to the seat platform. See figure 11.
3. Align the seat platform with the desired set of holes on the seat.
4. Replace and tighten the four bolts securely.

### SEAT HEIGHT ADJUSTMENT

The seat can be repositioned to one of three different heights. See figure 12.

1. Remove the seat from your scooter. See IX. "Disassembly and Assembly."
2. Use the attached ring to pull and remove the detent pin from the lower seat post.
3. Raise or lower the upper seat post to the desired seat height.
4. While holding the upper seat post at that height, match up the adjustment holes in the upper and lower seat posts.
5. Fully insert the detent pin.
6. Replace the seat.

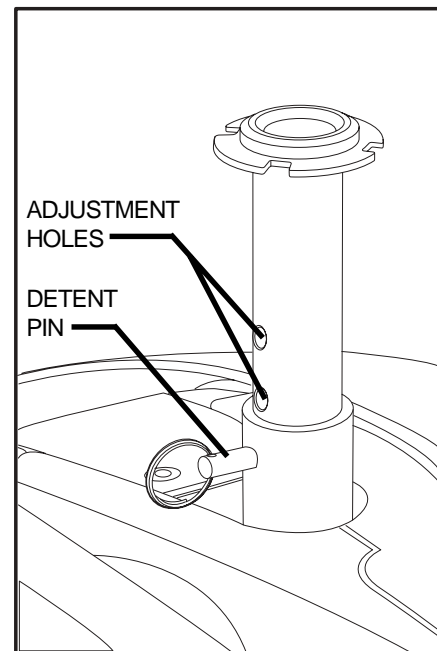

Figure 12. Seat Height Adjustment

# IX. DISASSEMBLY AND ASSEMBLY

## DISASSEMBLY

You can disassemble the scooter into seven pieces: the seat, the front section, the rear section, the rear shroud, the basket, and the batteries. See figure 13. No tools are required to disassemble or assemble your scooter, but keep in mind that the disassembled sections of the scooter take up more floor space than the assembled unit. Always disassemble or assemble your scooter on a level, dry surface with sufficient room for you to work and move around your scooter-about 5 feet in all directions. Remember that some scooter components are heavy and you may need assistance when lifting them.



**WARNING!** Lifting weight beyond your physical capability may result in personal injury. Ask for assistance when necessary while disassembling or assembling your scooter.

To disassemble:

1. Remove the key and ensure that the manual free-wheel lever is in the drive (locked) position.
2. Lock the tiller in place by positioning it forward then pushing the tiller lock knob inward and turning it clockwise 90 degrees. See figure 14.
3. Remove the seat by pulling up on the seat lock lever, rotating the seat one-eighth of a turn, and lifting the seat up and off of the scooter.
4. Disengage the left battery pack lock by pulling it outward from the scooter. See figure 15.
5. Remove the left battery pack by lifting it straight up and away from the scooter. See figure 15.
6. Remove the right battery pack in the same manner as in the above step.
7. Unplug the front-to-rear harness. See figure 16.

**Reverse the above steps to assemble the scooter.**

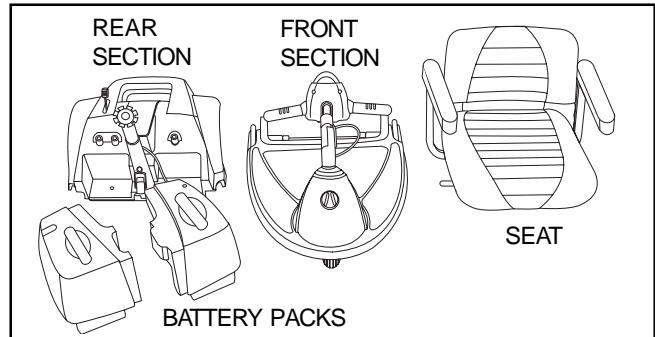

Figure 13. Scooter Components

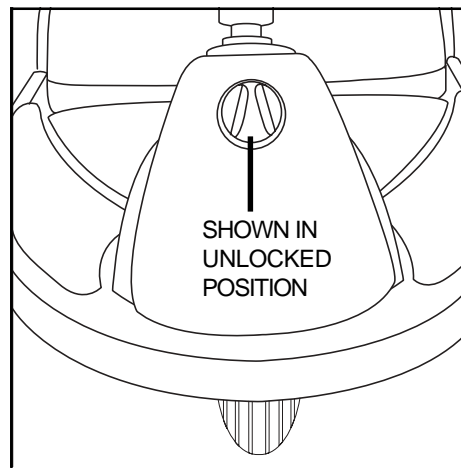

Figure 14. Tiller Lock Knob

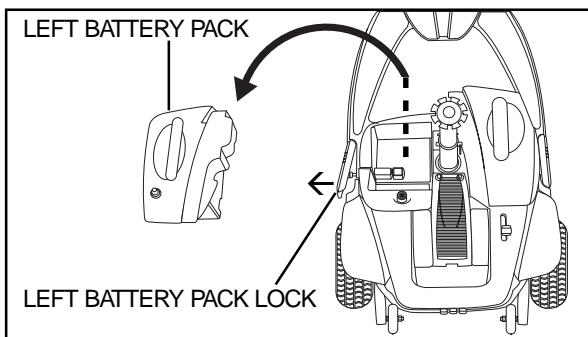

Figure 15. Battery Pack Removal/Installation

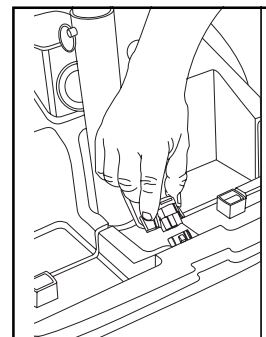

Figure 16. Front-To-Rear Harness

**NOTE:** When *DISASSEMBLING* the scooter, always remove the *LEFT* battery pack first. When *ASSEMBLING* the scooter, always reinstall the *RIGHT* battery pack first.

# IX. DISASSEMBLY AND ASSEMBLY

## Toggle Latch Release

1. Push in the toggle latch release button while pulling back the toggle latch. See figures 18 and 18A.
2. Secure the toggle latch buckle over the top of the toggle latch. See figure 18B.
3. Grab the hand grip on the tiller, loosen the tiller adjustment knob, and gently lower the tiller down to the center of the scooter floorboard.
4. Fully tighten the tiller adjustment knob.

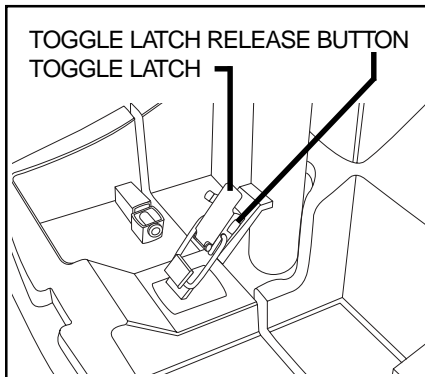

Figure 18. Toggle Latch (Latched)

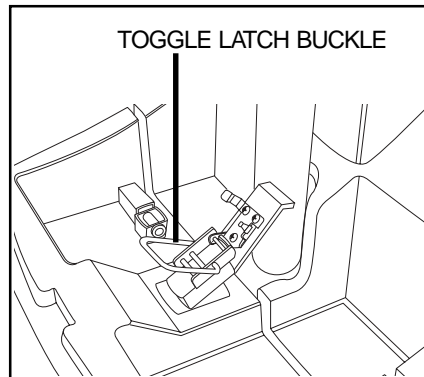

Figure 18A. Toggle Latch (Unlatched)

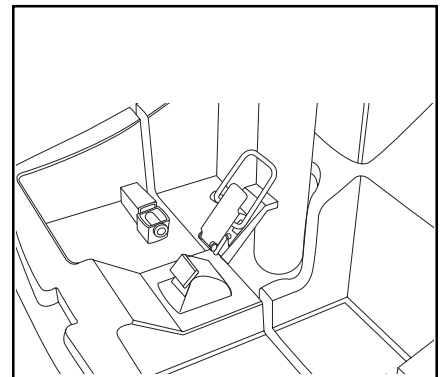

Figure 18B. Toggle Latch (Secured For Disassembly)

## Frame Separation

1. Push back on the seat post to pivot the scooter's rear section rearwards until it is standing vertically on its rear bumper. See figure 19.
2. Lift the front section up until the rear pegs are no longer in the locking brackets. See figure 20.
3. Carefully move the front section away from the rear section.

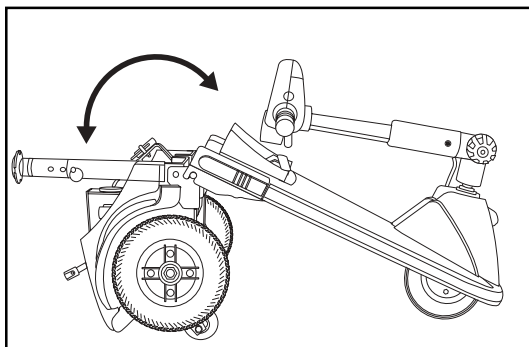

Figure 19. Frame Positioning

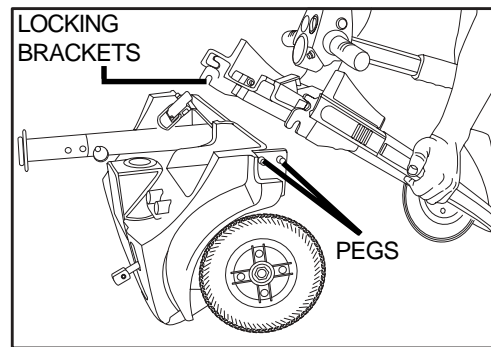

Figure 20. Frame Separation



# IX. DISASSEMBLY AND ASSEMBLY

## ASSEMBLY

1. Position the front and rear sections of your scooter as shown in figure 20.
2. Align the locking brackets of the front section with the corresponding pegs on the front of the rear section.



WARNING! Position the front-to-rear harness cable so it won't become pinched between the frame halves when pivoting the rear section forward.

3. Holding the seat post, slowly pivot the rear section forward until the locking brackets are fully connected onto the rear pegs. See figures 19 and 20.
4. Raise the tiller.
5. Latch the toggle latch. See figure 18.
  - Lower the toggle latch buckle.
  - Push back on the toggle latch so it locks into place.
6. Connect the front-to-rear harness.
7. Reinstall the battery packs and engage both battery pack locks. **Always replace the right battery pack first.**
8. Replace the seat, and lock it into place.
9. Unlock the tiller by rotating the tiller lock knob 90 degrees counterclockwise.



WARNING! Before getting onto your scooter always check that the tiller lock knob is in the unlocked position. Attempting to ride your scooter with the tiller lock knob in the locked position can result in personal injury.

# X. BASIC TROUBLESHOOTING

Any electromechanical device occasionally requires some troubleshooting. However, most of the problems that may arise can usually be solved with a bit of thought and common sense. Many of these problems occur because the batteries are not fully charged or because the batteries are worn down and can no longer hold a charge.

## DIAGNOSTIC FLASH CODES

The diagnostic flash codes for your scooter are designed to help you perform basic troubleshooting quickly and easily. A diagnostic flash code will flash from the status LED in the event one of the conditions listed below develops.

**NOTE:** *Your scooter will not run unless the flash code condition is resolved and the scooter has been turned off then turned back on.*

FLASH CODE	CONDITION	SOLUTION
■ (1)	Battery charge is low.	Charge batteries as soon as possible.
■ ■ (2)	Batteries are too low to operate the scooter or the charger is operating.	Charge batteries or unplug the charger power cord from the electrical outlet.
■ ■ ■ (3)	The scooter's battery voltage is too high to operate the scooter.	Insert the key into the key switch, turn the scooter's light on to drain power from the batteries.
■ ■ ■ ■ (4)	Current limit time out.	Turn the scooter off for a few minutes then turn your scooter back on.
■ ■ ■ ■ ■ (5)	The manual freewheel lever is in the (forward) freewheel position.	Remove the key from the key switch, then push the manual freewheel lever to the (rear) drive position, restart your scooter.
■ ■ ■ ■ ■ ■ (6)	Throttle control lever not at center position at start up.	Return the throttle control lever to center position, turn scooter off then back on.
■ ■ ■ ■ ■ ■ ■ (7)	Speed pot error.	Contact your authorized Pride Provider for assistance.
■ ■ ■ ■ ■ ■ ■ ■ (8)	Motor volts error.	Contact your authorized Pride Provider for assistance.
■ ■ ■ ■ ■ ■ ■ ■ ■ (9)	Other internal errors.	Contact your authorized Pride Provider for assistance.

### What if all the systems on my scooter seem to be “dead”?

- Make certain that the key is in the “on” position.
- Check that the batteries are fully charged.
- Push in the main circuit breaker reset button. See V. “Your Scooter.”
- Make certain that both batteries are seated properly.
- Make sure that the front-to-rear harness is firmly connected. See IX. “Disassembly and Assembly.”
- Be sure the power down timer feature hasn't been activated. See VII. “Operation.”

### What if my scooter does not move when I press the throttle control lever?

- When the manual freewheel lever is pushed forward, the brakes are disengaged and all power to the motor/transaxle assembly is cut.
- Push back on the manual freewheel lever, turn the scooter off, and then turn the scooter on to return to normal scooter operation.

## X. BASIC TROUBLESHOOTING

### **What if the main circuit breaker repeatedly trips?**

- Charge the scooter's batteries more frequently. See VI. "Batteries and Charging."
- If the problem continues, have both of your scooter's batteries load tested by your authorized Pride Provider.
- You may also perform the load test yourself. Battery load testers are available at most automotive parts stores.
- Follow the directions supplied with the load tester.
- See VI. "Batteries and Charging" or IV. "Specifications" for information about your scooter's battery type.
- Contact your authorized Pride Provider.

### **What if the battery condition meter dips way down and the motor surges or hesitates when I press my scooter's throttle control lever?**

- Fully charge your scooter's batteries. See VI. "Batteries and Charging."
- Have your authorized Pride Provider load test each battery.
- Or, see the previous troubleshooting question for load testing the batteries yourself.

If you experience any problems with your scooter that you are not able to solve, immediately contact your authorized Pride Provider for information, maintenance, and service.

# XI. CARE AND MAINTENANCE

Your scooter requires a minimal amount of care and maintenance. If you do not feel confident in your ability to perform the maintenance listed below, you may schedule inspection and maintenance at your authorized Pride Provider. The following areas require periodic inspection and/or care and maintenance.

## TIRE PRESSURE

- If equipped with pneumatic tires, always maintain a proper **30-35 psi** tire pressure.



WARNING! It is important that 30-35 psi tire pressure be maintained in pneumatic tires at all times. Do not underinflate or overinflate your tires. Low pressure may result in loss of control, and overinflated tires may burst. Failure to maintain 30-35 psi tire pressure in pneumatic tires at all times may result in tire and/or wheel failure, causing serious personal injury and/or damage to your scooter.

- Regularly inspect your scooter's tires for signs of wear.

## EXTERIOR SURFACES

Bumpers and tires can benefit from an occasional application of a rubber or vinyl conditioner.



WARNING! Do not use a rubber or vinyl conditioner on the scooter's vinyl seat or tire tread. They will become dangerously slippery and result in personal injury and/or damage to your scooter.

## BATTERY TERMINAL CONNECTIONS

- Make certain that the terminal connections remain tight and uncorroded.
- The batteries must sit flat in the battery wells.

## WIRING HARNESSES

- Regularly check all wiring connections.
- Regularly check all wiring insulation, including the charger power cord, for wear or damage.
- Have your authorized Pride Provider repair or replace any damaged connector, connection, or insulation that you find before using your scooter again.

## ABS PLASTIC SHROUDS

- The front tiller shroud, front shroud, and the rear shroud are formed from durable ABS plastic and are coated with an advanced formula urethane paint.
- A light application of car wax will help the shrouds retain their high gloss.

## AXLE BEARINGS AND THE MOTOR/TRANSAXLE ASSEMBLY

These items are all prelubricated, sealed, and require no subsequent lubrication.

## MOTOR BRUSHES

The motor brushes are housed inside of the motor/transaxle assembly. They should be inspected periodically for wear by your authorized Pride Provider.

# XI. CARE AND MAINTENANCE

## CONSOLE AND REAR ELECTRONICS

- Keep these areas free of moisture.
- Allow these areas to dry thoroughly if they have been exposed to moisture before operating your scooter again.

## FUSE REPLACEMENT

In the event a fuse should cease to work:

1. Remove the fuse by pulling it out of its slot.
2. Examine the fuse to be sure it is blown. See figures 21 and 21A.
3. Insert a new fuse of the proper rating.

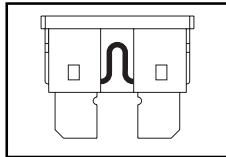

Figure 21. Working Fuse

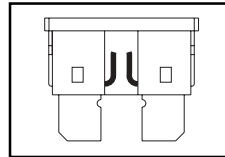

Figure 21A. Blown Fuse (Replace)



**WARNING!** The replacement fuse must exactly match the rating of the new fuse. Failure to use properly rated fuses may cause damage to the electrical system and may result in personal injury.

## LIGHT BULB REPLACEMENT

The scooter's light bulbs are easily replaceable. Do not use regular automotive-type 12-volt light bulbs; your scooter is equipped with a 24-volt electrical system. Replacement light bulbs can be purchased from your authorized Pride Provider.

**NOTE:** Use only 24-volt light bulbs.

1. Remove the light cover.
2. Gently remove the bulb by pulling it straight out.
3. Insert a new bulb of the same wattage.
4. Replace the light cover.

## STORING YOUR SCOOTER

If you plan on not using your scooter for an extended period of time, it is best to:

- Fully charge its batteries prior to storage.
- Remove the battery packs from the scooter.
- Store your scooter in a warm, dry environment.
- Avoid storing your scooter where it will be exposed to temperature extremes.



**WARNING!** Always protect batteries from freezing temperatures and never charge a frozen battery. This damages the battery and can cause personal injury.

For prolonged storage, you may wish to place several boards under the frame of your scooter to raise it off of the ground. This takes the weight off the tires and reduces the possibility of flat spots developing on the areas of the tires contacting the ground.

# XII. WARRANTY

## THREE-YEAR LIMITED WARRANTY

For three (3) years from the date of purchase, Pride will repair or replace at our option to the original purchaser, free of charge, any of the following parts found upon examination by an authorized representative of Pride to be defective in material and/or workmanship:

### Structural Frame Components, Including:

- Main Frame
- Fork
- Seat Post
- Tiller Frame

## THREE-YEAR PRORATA WARRANTY

Three-year prorata drivetrain warranty, including:

- Transaxle
- Motor Brake (electronic function ONLY)
- Brake

These components will be prorated on the following schedule:

- First year: 100% replacement of parts cost
- Second year: 67% replacement of parts cost
- Third year: 50% replacement of parts cost

*NOTE: If there is an increase in the operational noise level in the transaxle, the warranty does not apply. An increase in operational noise level usually occurs due to abusive and excessive strain on the scooter.*

## ONE-YEAR LIMITED WARRANTY

For one (1) year from the date of purchase, Pride will repair or replace at our option to the original purchaser, free of charge, any of the following parts found upon examination by an authorized representative of Pride to be defective in material and/or workmanship:

- Bearings
- Bushings
- Rubber Components
- Plastic components except body

### Also, electronic assemblies including:

- Electronic Controllers
- Chargers
- Harnesses
- Any other electrical subassembly

## SIX-MONTH WARRANTY

The battery is covered by a separate six-month warranty, provided by the battery manufacturer. The batteries are not warranted by Pride.

## RECONDITIONED UNITS WARRANTY

All reconditioned units are covered by a six-month warranty from Pride effective from the date of purchase.

## WARRANTY EXCLUSIONS

This warranty does not extend to those items which may require replacement due to normal wear and tear.

- ABS Plastic shrouds
- Motor brushes
- Upholstery and seating
- Brake Pads
- Tires and tubes
- Fuses/Bulbs

## XII. WARRANTY

- Circumstances beyond the control of Pride
- Labor, service calls, shipping, and other charges incurred for repair of the product, unless specifically authorized, IN ADVANCE, by Pride Mobility Products Corporation
- Repairs and/or modifications made to any part without specific consent from Pride

**Exclusions also include components with damage caused by:**

- Contamination
- Abuse, misuse, accident, or negligence
- Battery fluid spillage or leakage
- Commercial use, or use other than normal
- Improper operation, maintenance, or storage

*NOTE: Gradual deterioration in performance because the battery has been left in a discharged state, left in cold conditions for an extended period of time, or worn out through heavy use is not covered.*

### **SERVICE CHECKS AND WARRANTY SERVICE**

Warranty service must be performed by an authorized Pride Provider. Do not return faulty parts to Pride without prior written authorization. All transportation costs and shipping damage incurred while submitting parts for repair or replacement are the responsibility of the purchaser. Please contact your authorized Pride Provider for information on the current cost associated with a service visit.

There is no other express warranty.

### **IMPLIED WARRANTIES**

Implied warranties, including those of merchantability and fitness for a particular purpose, are limited to one (1) year from the date of original purchase and to the extent permitted by law. Any and all implied warranties are excluded. This is the exclusive remedy. Liabilities for consequential damages under any and all warranties are excluded.

Some states do not allow limitations on how long an implied warranty lasts or do not allow the exclusion of limitation of incidental or consequential damages. So, the above limitation or exclusion may not apply to you.

# NOTES



# NOTES

# NOTES



**Pride**  
Mobility Products Corp.

182 Susquehanna Avenue  
Exeter, PA 18643  
1-800-800-8586

[www.pridemobility.com](http://www.pridemobility.com)

\*INVAUL2427\*