OWNER'S & OPERATING MANUAL

Please read this manual before operating your scooter

“Simplicity in Mobility”



zip'r3



zip'r4



zip'r xtra

Zip'r™ Mobility
(800) 760-9107

TABLE OF CONTENTS

SAFETY INFORMATION..... Pg. 3

EMI/RFI WARNING..... Pg. 4

YOUR ZIP'R..... Pg. 5

ASSEMBLY & DISASSEMBLY..... Pg. 6-7

BATTERY CHARGING..... Pg. 8

OPERATING YOUR ZIP'R..... Pg. 9

SPECIFICATIONS Pg. 10

CARE & MAINTENANCE..... Pg. 11

TROUBLESHOOTING..... Pg. 12

WARRANTY..... Pg. 13

ZIP'R MOBILITY CONTACT INFORMATION

(800) 760 – 9107 www.zipr.com

MY AUTHORIZED DEALER: _____

DEALER TELEPHONE #: _____

ZIP'R SERIAL #: _____

(Located underneath the scooter battery box)

SAFETY INFORMATION

Please read and understand these warnings and the entire manual before using your Zip'r Mobility Scooter.

IMPORTANT – This vehicle is not intended for use as a medical device.

Important DOs

- **Always** turn the key switch OFF before getting on/off your scooter.
- **Always** turn the power off when the unit is not in use.
- **Always** Unlock tiller lock (located at the bottom of the tiller) prior to operating scooter.
- **Always** make sure your seat is locked before driving your scooter.
- **Always** remain seated while driving your scooter.
- **Always** keep legs and arms within the confines of the scooter.
- **Always** drive straight up and down inclines.
- **Always** be extra cautious when operating the scooter on wet surfaces and steep inclines or ramps.
- **Always** drive slowly while turning.
- **Always** come to a complete stop before attempting to reverse.
- **Always** use a grounded power receptacle when charging. Use of a non-grounded receptacle could result in an electrical shock.
- **Always** remember scooter capacity is limited to one person only. This scooter is not approved for towing or for weights in excess of the published maximum.
- **Always** avoid sudden starts while the handle is turned sharply.
- **Always** be aware of mechanical pinch points when assembling and disassembling your scooter.

Important DO NOTs

- **Never** modify the scooter in anyway or use it for a purpose other that intended.
- **Never** attempt to drive over or off obstacles higher than 1 inch. This could be unsafe and could damage the scooter.
- **Never** operate this scooter after consuming alcoholic beverages.
- **Never** operate this scooter if your health or medications you are taking cause you to feel dizzy, affect your vision, or in anyway effect your ability to safely operate the scooter.
- **Never** reverse down a steep hill or incline.
- **Never** park on inclines or declines.
- **Never** stop on an incline. If you must stop on an incline, then always lean forward to shift the center of gravity and prevent the scooter from tipping over backwards.
- **Never** attempt to turn on an incline or decline.
- **Never** turn off the power while the scooter is moving. Doing so will cause the scooter to come to an abrupt stop.
- **Never** operate your scooter on streets or other areas with vehicular traffic.
- **Never** operate your scooter near steps or curbs where you might accidentally drop a wheel off of the edge.
- **Never** hose off your scooter or leave your scooter uncovered in heavy rain.
- **Never** charge batteries that may be frozen.

EMI/RFI WARNING

RADIO WAVE SOURCES MAY AFFECT POWERED MOBILE VEHICLE CONTROL.

Electromagnetic (EMI) or Radio Frequency Interference (RFI) refers to the effects that outside sources of such energy might have on the control systems of your mobility vehicle. The interference from these sources could cause the vehicle to release its brakes, move by itself, and/or cause damage to the mobility vehicle controller.

The sources of EMI/RFI can be broadly classified into three types:

- Handheld portable transceivers with antenna mounted directly on the transmitting unit. Examples include: citizens band radios (CB), "walkie talkies", security, fire and police transceivers, cellular telephones, and other personal communication devices.
- Medium range mobile transceivers. These usually have the antenna mounted outside of a vehicle or a building. Examples include: police, fire, ambulance and taxi receivers.
- Long range transmitters and receivers, such as commercial broadcast transmitters (radio and TV broadcast antenna towers) and amateur (HAM) radios.

Note: So far as we know, other types of handheld devices, such as cordless phones, laptop computers, AM/FM radios, TV sets, CD players and cassette players and small appliances such as electric shavers and hair dryers are not likely to cause EMI/RFI problems to your mobility vehicle.

SAFETY PRECAUTIONS

The following are some precautions you can take to reduce the risk of a mobility vehicle from being affected by EMI/RFI.

1. Do not turn on or use hand held personal communication devices, such as citizens band radios (CB) and cellular phones while your vehicle is turned on.
2. Be aware of nearby transmitters, such as TV or radio stations and try to avoid coming close to them.
3. Be aware that adding accessories and/or components, or modifying your mobility vehicle in any way, may change its EMI/RFI resistance level, thus making it more susceptible to interference from radio wave sources.
4. Turn off your mobility vehicle by removing the key from the key switch when you are getting onto or off of your mobility vehicle and never leave the key in the key switch of an unattended mobility vehicle.
5. Report all incidents of unintended movement or unexpected brake releases to Zip'r Mobility.

YOUR ZIP'R3

Components

The Zip'r3 consists of the following major components shown below.

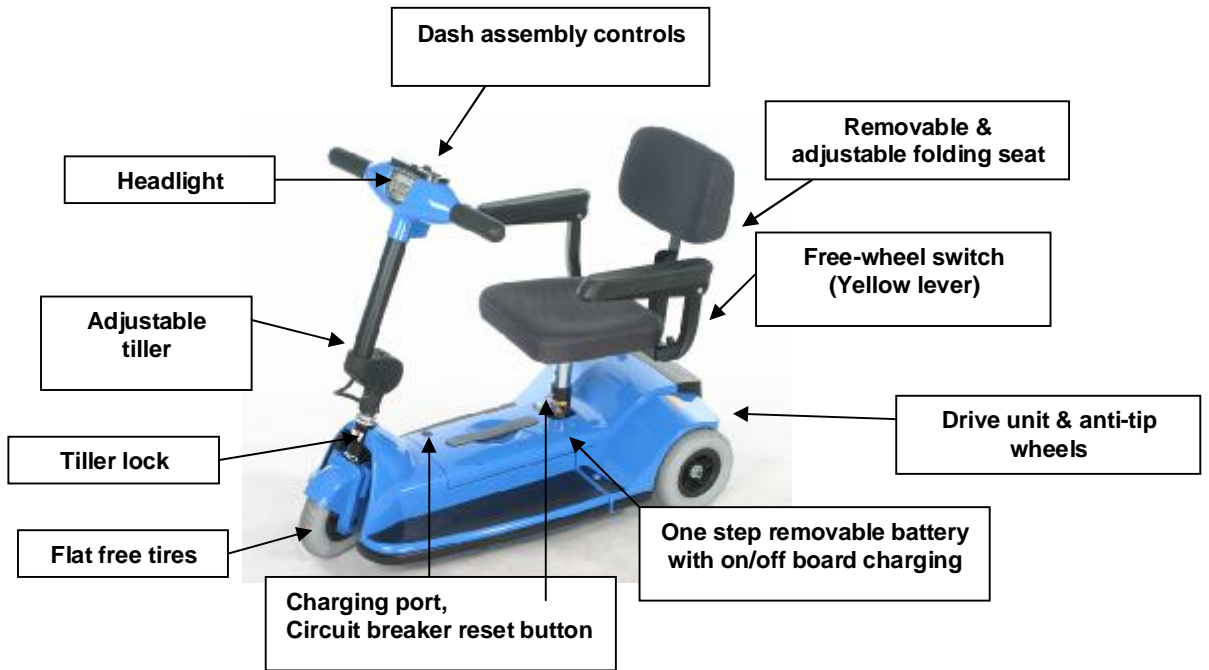

Dash Assembly Controls Detail

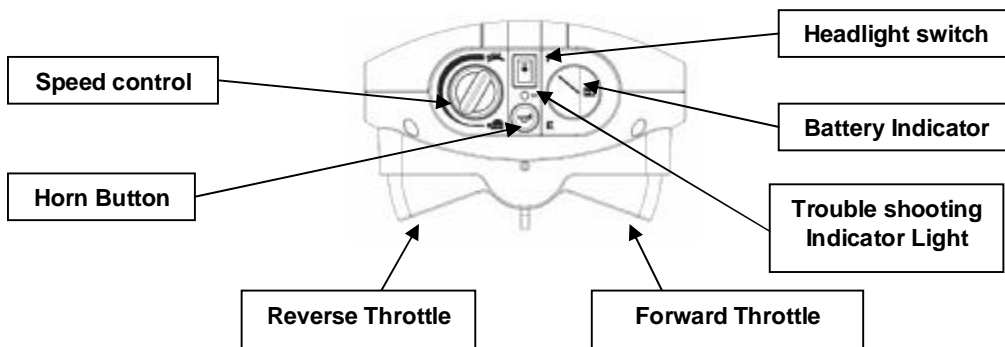

ASSEMBLY AND DISASSEMBLY

The following are the steps required to assemble your Zip'r. Disassembly can be achieved by following all of the steps in the reverse order.

Figure 1. There are five main sections that need to be assembled: Front frame, rear frame, battery box, seat post, and folding seat.

Figure 2. To begin assembly, tilt the rear frame back so it is freely standing on the rear bumper. Lift the front frame up and set it down onto the rear frame by connecting (setting down) the front frame curved locking brackets (one on each side) onto the rear frame bracket pegs (one on each side).

Figure 3. After the steps in Figure 2 have been completed, the scooter should be in this position.

Figure 4. Take note of the latch in the middle of the rear frame. This latch must be pressed together during disassembly in order to release the rear frame from the front frame.

Figure 5. Holding the seat post, slowly pivot the rear frame forward and down until the latch in Figure 4. locks onto the front frame locking peg.



Figure 1.



Figure 2.



Figure 3.



Figure 4.



Figure 5.

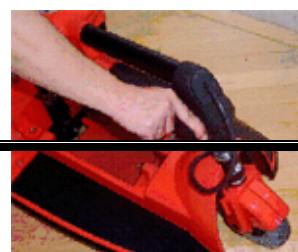

...assembly/disassembly continued,

Figure 6. Loosen tiller adjustment knob, raise the tiller to the desired angle, and then retighten the tiller adjustment knob. Unlock tiller lock located at the bottom front of the scooter tiller by pushing and turning knob. (**WARNING** scooter will not turn if lock is not released. The tiller lock should only be locked during transportation of scooter)

Figure 7. Carefully place the battery box into battery compartment. Lightly press down on the front and rear of the battery box to ensure that the front to rear power connections have engaged.

Figure 8. Insert the chrome seat post extension into the seat post. Insert the seat post pin at the desired seat height.

Figure 9. Install the seat by lowering the seat into the seat post extension and rotating until it locks into the correct position. Note: The scooter seat rotates by pulling on the seat release lever (located at the right of the seat) while rotating the seat in either direction.

Figure 10. The fully assembled Zip'r Scooter.

Disassembly of your scooter can be accomplished by following the above steps in reverse order.

Figure 6.



Figure 7.



Figure 8.



Figure 9.



Figure 10.

BATTERY CHARGING



Figure 11.



Figure 12.

A Battery Charger similar to that shown in Figure 11. above is supplied with your Zip'r. Your Zip'r is equipped with two sealed, maintenance free 12 AH batteries.

The battery condition can be monitored on the battery indicator meter located on the tiller console, see Figure 12., Green color indicates fully charged battery and red color indicates that an immediate recharge is necessary. Note: To check the battery strength during charging, you must first unplug the charger power cord and turn the power on to your scooter by inserting and turning the key switch.

CAUTION

FAILURE TO FOLLOW THESE SAFETY INSTRUCTIONS MAY RESULT IN PERSONAL INJURY OR PROPERTY DAMAGE.

- Do not operate charger in a closed-in area or restrict ventilation in any way.
- Never use an extension cord to plug in your battery charger. Plug charger directly into standard wall outlet.
- Never smoke or allow an open flame in the vicinity of the battery.
- Sparks near the battery may cause explosion. To reduce the risk of spark:
 - When connecting charger, connect DC charging cord to the battery charge plug before connecting Charger AC cord to electrical outlet.
 - When disconnecting charger, always do so in reverse order of the connecting procedure.
 - Always avoid/prevent damage to AC and DC cords.

HAZARD WARNING

UNDER NO CIRCUMSTANCE SHOULD YOU TOUCH BATTERIES IF THEY ARE LEAKING. IF YOUR BATTERY IS DAMAGED, CONTACT ZIP'R MOBILITY IMMEDIATELY.

Steps in charging your battery safely:

(Note that your Zip'r battery can be charged on or off- board)

1. Place the scooter/battery near a standard wall outlet.
2. Remove key from the scooter key switch.
3. Confirm that the manual freewheel lever (yellow cap) (see Figure 13. below) is in the drive (pushed back) position.
4. Remove the charger port cover and insert the 3-pin off-board plug into the charger port. (see Figure 14. below)
5. Plug the battery charger into the wall outlet. It is recommended that you charge your batteries for 8 to 10 hours.
6. When the battery is fully charged, unplug the off-board plug from the wall outlet and then the 3-pin plug from the charger port. Replace the charger port cover.



Figure 13.



Figure 14.

OPERATING YOUR ZIP'R

Check The Following Before Operating Your Scooter

- Verify that the freewheel brake lever is in the rear (drive) position.
- Verify that the front till lock is UNLOCKED
- Verify that the seat is in the correct position and is securely locked.
- Verify that the steering tiller is tightened securely.
- Sit down on your scooter.
- Insert the key only after you have completed the above steps.
- Verify that the horn and head light work properly.
- Plan your route to avoid numerous inclines and obstacles.
- Observe your surroundings for other safety concerns.

WARNING

- ALWAYS REMOVE THE KEY FROM THE KEY SWITCH PRIOR TO ENTERING OR EXITING YOUR SCOOTER. THIS WILL PREVENT SCOOTER MOVEMENT IF THE THROTTLE LEVERS ARE ACCIDENTALLY PRESSED.
- ALWAYS VERIFY THAT SCOOTER TILLER LOCK IS UNLOCKED BEFORE OPERATING SCOOTER.
- ALWAYS BRING YOUR SCOOTER TO A COMPLETE STOP BEFORE ENTERING OR EXITING THE SCOOTER.
- THE ZIP'R3 IS EQUIPPED WITH ANTI-TIP WHEELS, BUT THE SCOOTER SHOULD NEVER EXCEED A CLIMBING SLOPE OF 12 DEGREES.

Operating Procedures

1. Set the speed adjustment dial to the desired speed (Turtle = Slower and Rabbit = Faster).
2. Press your thumb against the appropriate throttle control lever (Right = Forward and Left = Reverse).
3. Release the throttle control lever to decelerate and come to a complete stop (Note: There is no external break control – the scooter will come to quick and complete stop when the throttle control lever is released).
4. Pull on the left hand grip to turn left and on the right hand grip to turn right.

Driving Basics

- Always use caution when driving your scooter in reverse. Note that the reverse speed is 50% slower than the forward speed.
- Avoid shortcutting sidewalk corners as it can cause the back wheel to drive off of the sidewalk.
- Enter narrow driving paths/doorways slowly and with caution and always look out for additional obstacles such as car mirrors or door knobs.
- It is recommended that the scooter speed be reduced when driving down or up hills.
- Avoid obstacles higher than 1 inch as this may cause damage to your scooter.

SPECIFICATIONS

	Zip'r3	Zip'r4	Zip'r3 Xtra	Zip'r4 Xtra
Overall Dimensions: L x W x H	36.4" x 19.5" x 27"	36.4" x 19.5" x 27"	40.5" x 19" x 28"	40.5" x 19" x 28"
Front Tires	1 pcs 2.0" x 7.5"	2 pcs 2.0" x 7.5"	2 pcs 2.0" x 7.5"	2 pcs 2.0" x 7.5"
Rear Tires	2 pcs 2.5" x 7.5"	2 pcs 2.5" x 7.5"	2 pcs 2.5" x 7.5"	2 pcs 2.5" x 7.5"
Weight - Total	102 lbs	106 lbs	107 lbs	111 lbs
Weight - Heaviest Piece	29 lbs	29 lbs	33 lbs	33 lbs
Battery	12 V, 12 AH, 2pcs	12 V, 12 AH, 2pcs	12 V, 12 AH, 2pcs	12 V, 12 AH, 2pcs
Battery Charger	Off board, 2A current	Off board, 2A current	Off board, 2A current	Off board, 2A current
Power Rating of Motor	155 W, .21 hp	155 W, .21 hp	155 W, .21 hp	155 W, .21 hp
Ground Clearance	2.1"	2.1"	3"	3"
Turning Radius	30"	38"	40"	43"
Maximum Weight Capacity	250 lbs	250 lbs	250 lbs	250 lbs
Body Colors	Red/Blue	Red/Blue	Red/Blue Gloss Paint	Red/Blue Gloss Paint
Seat Type	Foldable foam filled	Foldable foam filled	Upgraded Foldable foam filled	Upgraded Foldable foam filled
Per-Charge Range (Max)	10 miles	10 miles	10 miles	10 miles
Maximum Speed	4.25 mph	4.25 mph	4.25 mph	4.25 mph

CARE AND MAINTENANCE

Your Zip'r3 requires a minimal amount of maintenance. The following are the maintenance items that should be followed to ensure that your scooter is safe and reliable.

Daily

- Charge your battery daily if your scooter is used for more than twenty minutes.
- Always store your scooter in a warm and dry environment.

Cleaning

- The scooter shroud is made from durable ABS plastic with a high gloss type finish. Therefore, the body can be cleaned like a car (cool water and mild soap to remove dirt/oils). DO NOT SPRAY THE ENTIRE SCOOTER WITH WATER AS THIS WILL DAMAGE ELECTRICAL PARTS AND UPHOLSTERY. A light application of car wax will help the shroud retain its high gloss.
- Use a rubber conditioner on your scooter's tire sidewalls to help preserve them.
- Bumpers and trim benefit from an occasional application of rubber or vinyl conditioner.

HAZARD WARNING

- DO NOT APPLY RUBBER CONDITIONER ON TIRE TREAD; THIS MAY CAUSE THE TIRES TO BECOME DANGEROUSLY SLIPPERY. ALSO DO NOT USE A RUBBER OR VINYL CONDITIONER ON THE SCOOTER'S VINYL SEAT OR FLOORBOARD. THEY WILL BECOME DANGEROUSLY SLIPPERY AND RESULT IN PERSONAL INJURY AND/OR DAMAGE YOUR SCOOTER.
- ALWAYS PROTECT BATTERIES FROM FREEZING TEMPERATURES AND NEVER CHARGE A FROZEN BATTERY. THIS DAMAGES THE BATTERY AND CAN CAUSE PERSONAL INJURY.

Maintenance

- Regularly check your scooter tires for wear.
- Regularly check you scooter seat posts for wear.
- All axle bearings and motor/transaxle assembly are prelubricated, sealed and require no subsequent lubrication.
- Keep the console, charger, battery, and electronics free of moisture.
- For prolonged storage, you may wish to place several boards under the frame of your scooter to raise off of the ground. This reduces the possibility of flat spots developing on the flat free tires.

TROUBLESHOOTING

As with any electromechanical device, electric scooters may occasionally require troubleshooting. Many of such issues can be resolved by referring to the options below.

If the vehicle will not move, please check to ensure the following:

- The battery box is inserted fully and correctly.
- The brake release lever (free wheel lever) is in the drive position (rear position).
- The battery is charged.
- The key is in the ignition and turned on.

If the scooter has power but does not move, please check to ensure the following:

- The scooter may have been left in free wheel mode (brake release lever in forward position). If this is the case then remove your key from the ignition, push the free-wheel lever to the drive position (rear position), and then reinsert your key into the ignition and turn the scooter on.

If the battery does not seem to hold a charge or the motor surges/hesitates when the throttle is pressed, then:

- Fully charge your scooter's battery (see section "Battery Charging").
- Remove the battery case cover (via removing philips screws) and replace fuse inside.
- A load test should be conducted on each battery.

If there seems to be no power to your scooter, then check to ensure the following:

- The battery box is correctly seated and pressed into position. Press each end of the battery into its seat. Check the quality and stability of male and female power plugs.
- Verify that the battery has been fully charged (see section "Battery Charging").
- Push the main circuit breaker reset button (see section "Your Zip'r3").
- Remove the battery case cover (via removing philips screws) and replace fuse inside.

Self Diagnostic Warning Light (Trouble Shooting LED Indicator)

Your scooter is equipped with a Self-Diagnostic Warning Light, also called Trouble Shooting Indicator Light located on the Dash Assembly Controls (see the Your Zip'r3 section). To check the Self-Diagnostic Warning Light, turn on the key and count the number of flashes on the Warning Light and refer to the chart below. **If the LED indicator blinks continuously without stopping but the scooter operate appropriately then this is a warning that the battery will soon need a full charge.**

No. of Flashes	Explanation
1	Battery needs charging or there is a poor battery connection. Charge the battery fully and check battery connections and then turn key switch off and on.
2	Poor Motor Connection. Check all connections between the motor and dash board controller and then turn key switch off and on.
3	Potential short circuit between motor and battery. Contact Zipr Mobility for assistance.
6	The scooter has entered drive inhibited mode, this may be a result of the battery charger still being connected to the scooter. Disconnect and turn the key off and on.
7	A throttle fault has occurred. Verify that the throttle is not stuck in forward/reverse and then turn the key switch off and on.
8	A controller fault has occurred. Check to see that all connections from the controller are secure and then turn the key switch off and on.
9	Free wheel lever (parking brake) is not in the drive position. Firmly push the lever to the rear position and then turn the key switch off and on.
10	An excessive amount of voltage has been applied to the controller. This is usually caused by a poor battery connection. Check connections and turn key off and on.

WARRANTY

If you purchased a warranty from a dealer then contact your dealer directly for details and warranty service. If you purchased a Zip'r Mobility manufacturer's warranty with your product then the warranty below applies to your scooter. If you did not purchase a warranty with your product and you need service please contact Zipr Mobility or an authorized dealer for assistance.

THREE-YEAR LIMITED WARRANTY

Three years on all structural frame components; including platform, fork, seat post, and frame. 100% or replacement parts cost.

ONE-YEAR LIMITED WARRANTY

One year on drive train components, including: transaxle, motor, and electronic components. 100% of replacement parts cost.

Warranty service can be performed by Zip'r Mobility or an authorized Zip'r Mobility provider. **Do not return faulty parts to Zip'r Mobility without prior consent.**

WARRANTY EXCLUSIONS

The following are wear items and not warranted:

- ABS plastic shrouds and footrest
- Motor brushes
- Break pads
- Tires
- Upholstery and seating
- Batteries

OTHER ITEMS NOT WARRANTED:

Repairs and/or modifications made to any part of the scooter without specific and prior consent from Zip'r Mobility, circumstances beyond control of Zip'r Mobility, labor service calls, and shipping costs and other charges incurred for repair of the product.

There is no other express warranty. Implied warranties, including those of merchantability and fitness for a particular purpose, are limited to one (1) year from the date of original purchase and to the extent permitted by law. Any and all implied warranties are excluded. This is the exclusive remedy. Liabilities for consequential damages under any and all warranties are excluded.

Some states do not allow limitations on how long an implied warranty lasts or exclusion of limitation of incidental or consequential damages.

All warranty claims must be accompanied by proof of purchase and product serial number. Please keep a copy of your original purchase receipt and serial number (located under battery box) for warranty claims and/or product reference.

Warranty is only valid for products purchased and shipped within the continental USA.

Zipr Mobility contact information :

Web site: www.Zipr.com
Telephone: (800) 760 - 9107