

# Jazzy 1104

## Owner's Manual

**ATTENTION:**  
Please read the content  
of your owner's manual  
before operating your  
power chair.



**How a Power Chair Should Feel!™**

**Pride**  
Mobility Products Corp.

Exeter, PA  
St. Catharines, ON

1-800-800-8586

[www.pridemobility.com](http://www.pridemobility.com)

# SAFETY GUIDELINES

Please read and follow all instructions in this owner's manual before attempting to operate your power chair for the first time. If there is anything in this manual you do not understand, or if you require additional assistance for set-up, contact your authorized Pride provider.

Using your Pride product safely depends upon your diligence in following the warnings, cautions, and instructions in this owner's manual. Using your Pride product safely also depends upon your own good judgement and/or common sense, as well as that of your provider, caregiver, and/or healthcare professional. Pride is not responsible for injuries and/or damage resulting from any person's failure to follow the warnings, cautions, and instructions in this owner's manual. Pride is not responsible for injuries and/or damage resulting from any person's failure to exercise good judgement and/or common sense.

The symbols below are used throughout this owner's manual to identify warnings and cautions. It is very important for you to read and understand them completely.



**WARNING! Failure to heed the warnings in this owner's manual may result in personal injury.**



**CAUTION! Failure to heed the cautions in this owner's manual may result in damage to your power chair.**

# CONTENTS

<b>I. INTRODUCTION</b> .....	4
<b>II. SAFETY</b> .....	6
<b>III. EMI/RFI</b> .....	14
<b>IV. THE JAZZY 1104</b> .....	16
<b>V. ASSEMBLY</b> .....	21
<b>VI. COMFORT ADJUSTMENTS</b> .....	23
<b>VII. DISASSEMBLY</b> .....	27
<b>VIII. OPERATION</b> .....	28
<b>IX. BATTERIES AND CHARGING</b> .....	31
<b>X. CARE AND MAINTENANCE</b> .....	36
<b>XI. OPTIONAL ACCESSORIES</b> .....	41
<b>XII. WARRANTY</b> .....	42

# I . I N T R O D U C T I O N

## **INTRODUCTION**

Welcome to Pride Mobility Products Corporation (Pride). Congratulations on the purchase of your new Pride Power Chair. The Pride Power Chair design combines the most advanced state-of-the-art components with modern, attractive styling. We are certain that the design features and trouble-free operation of your new power chair will add convenience to your daily living.

At Pride, your safety is important to us. Please read and follow all of the instructions in this manual before you attempt to operate your power chair for the first time. These instructions were produced for your benefit. Your understanding of these instructions is essential for the safe operation of your new power chair.

Pride is not liable for damage to property or personal injury arising out of unsafe use of a power chair. Pride is also not liable for any property damage or personal injury arising out of the failure of any person and/or user to following the instructions and recommendations set forth in this manual or any other instructions or recommendations contained in other power chair related literature issued by Pride or contained on the power chair itself.

This owner's manual is compiled from the latest specifications and product information available at the time of publication. We reserve the right to make changes as they become necessary. Any changes to our products may cause slight variations between the illustrations and explanations in this manual and the product you have purchased.

If you experience any problems with your power chair that you are unable to solve, or if you do not feel capable of safely following any of the instructions and/or recommendations as contained in this manual, please contact your authorized Pride provider for assistance.

Once you understand how to operate and take care of your power chair, we are certain that it will give you years of trouble-free service and enjoyment.

## **Information Exchange**

We want to hear your questions, comments, and suggestions about this manual. We would also like to hear about the safety and reliability of your new power chair, and about the service you received from your authorized Pride provider.

Please notify us of any change of address, so we can keep you apprised of important information about safety, new products, and new options that can increase your ability to use and enjoy your power chair. Please feel free to contact us at the address below:

Pride Mobility Products Corporation  
Attn: Customer Care Department  
182 Susquehanna Avenue  
Exeter, PA 18643-2694  
customer care@pridemobility.com  
800-424-8205

# I . I N T R O D U C T I O N

## **Pride Owners Club**

As an owner of a Pride product, you are invited to register your product's warranty and enroll in the Pride Owners Club. You may do so by filling out and returning your enclosed registration card or by visiting Pride's web site at [www.pridemobility.com](http://www.pridemobility.com). As a registered member, each time you visit our site, you will have access to the most interactive and honest educational venue available today for people with mobility needs, their families, and friends.

From our home page, select "Owners Club" to enter a page dedicated to current and potential Pride product owners. You will gain access to interviews, stories, recreation ideas, daily living tips, product and funding information, and interactive message boards. These message boards invited you to communicate with other Pride customers as well as Pride representatives who are available to assist you with any questions or concerns you may have.

## **My Authorized Pride Provider Is:**

Name: \_\_\_\_\_

Address: \_\_\_\_\_

Phone Number: \_\_\_\_\_

Purchase Date: \_\_\_\_\_

*NOTE: If you ever lose or misplace your product registration card or your copy of this manual, contact us and we will be glad to send you a new one immediately.*

# II. SAFETY

## SAFETY



**WARNING! Do not operate your new power chair for the first time without completely reading and understanding this owner's manual.**

Your power chair is a state-of-the-art life-enhancement device designed to increase mobility. Pride provides an extensive variety of products to best fit the individual needs of the power chair user. Please be aware that the final selection and purchasing decision regarding the type of power chair to be used is the responsibility of the power chair user, who is capable of making such a decision, and his/her healthcare professional (i.e., medical doctor, physical therapist, etc.).

The contents of this manual are based on the expectation that a mobility device expert has properly fitted the power chair to the user and has assisted the prescribing healthcare professional and/or the authorized Pride provider in the instruction process for the use of the product.

There are certain situations, including some medical conditions, where the power chair user will need to practice operating the power chair in the presence of a trained attendant. A trained attendant can be defined as a family member or care professional specially trained in assisting a power chair user in various daily living activities.

As you begin using your power chair during daily activities, you will probably encounter situations in which you will need some practice. Simply take your time and you will soon be in full and confident control as you maneuver through doorways, on and off of elevators, up and down ramps, and over moderate terrain.

Below are some precautions, tips, and other safety considerations that will help the user become accustomed to operating the power chair safely.

### Modifications

Pride has designed and engineered your power chair to provide maximum mobility and utility. A wide range of accessories is available from your authorized Pride provider to further customize your power chair to better suit your needs and/or preferences. However, under no circumstances should you modify, add, remove, or disable any feature, part, or function of your power chair.



**WARNING! Do not modify your power chair in any way not authorized by Pride. Unauthorized modifications may result in personal injury and/or damage to your power chair.**

### Pre-Ride Safety Check

Get to know the feel of your power chair and its capabilities. Pride recommends that you perform a safety check before each use to make sure your power chair operates smoothly and safely. See X. "Care and Maintenance."

## II. SAFETY

Perform the following inspections prior to using your power chair:

- Check for proper tire inflation. Maintain **30-35 psi** in each tire (if equipped with pneumatic tires).
- Check all electrical connections. Make sure they are tight and not corroded.
- Check all controller connections to the electronics tray. Make sure they are secured properly.
- Check the brakes. See X. "Care and Maintenance."
- Check battery charge. See IX. "Batteries and Charging."

*NOTE: If you discover a problem, contact your authorized Pride provider for assistance.*

### Weight Limitations

Your power chair is rated for a maximum weight capacity. Please refer to the specifications table for this limit.



**WARNING! Exceeding the weight capacity voids your warranty and may result in personal injury and/or damage to your power chair. Pride will not be held responsible for injuries and/or property damage resulting from failure to observe weight limitations.**

**WARNING! Do not carry passengers on your power chair. Carrying passengers on your power chair may result in personal injury and/or property damage.**

### Tire Inflation

If your power chair is equipped with pneumatic tires, you should check or have the air pressure checked at least once a week. Proper inflation pressures will prolong the life of your tires and help ensure the smooth operation of your power chair.



**WARNING! It is important that 30-35 psi tire pressure be maintained in pneumatic tires at all times. Do not underinflate or overinflate your tires. Low pressure may result in loss of control, and overinflated tires may burst. Failure to maintain 30-35 psi tire pressure in pneumatic tires at all times may result in tire and/or wheel failure, causing serious personal injury and/or damage to your Jazzy.**

**WARNING! Inflate your power chair drive tires from a regulated air source with an available pressure gauge. Inflating your tires from an unregulated air source could overinflate them, resulting in a burst tire and/or personal injury.**

### Incline Information

More and more buildings have ramps with specified degrees of inclination, designed for easy and safe access. Some ramps may have turning switchbacks (180-degree turns) that require you to have good cornering skills on your power chair.

- Proceed with extreme caution as you approach the downgrade of a ramp or other incline.
- Take wide swings with your power chair's front wheels around any tight corners. If you do that, the power chair's rear wheels will follow a wide arc, not cut the corner short, and not bump into or get hung up on any railing corners.
- When driving down a ramp, keep the power chair's speed adjustment set to the slowest speed setting to ensure a safely controlled descent. See VIII. "Operation."
- Avoid sudden stops and starts.

## II. SAFETY

When climbing an incline, try to keep your power chair moving. If you must stop, start up again slowly and then accelerate cautiously. When driving down an incline, set your power chair to the slowest setting and drive in the forward direction only. If your power chair starts to move down the incline faster than you anticipated or desired, allow it to come to a complete stop by releasing the joystick, then push the joystick forward slightly to ensure a safely controlled descent.

**WARNING! When climbing an incline, do not zigzag or drive at an angle up the face of the incline. Drive your power chair straight up the incline. This greatly reduces the possibility of a tip or a fall. Always exercise extreme caution when negotiating an incline.**



**WARNING! You should not travel up or down a potentially hazardous incline (i.e., areas covered with snow, ice, cut grass, or wet leaves).**

**WARNING! When on any sort of an incline or decline, never place the power chair in free-wheel mode while seated on it or standing next to it. Doing so may result in personal injury and/or damage to your power chair.**

**WARNING! Never travel down an incline backwards. This may result in personal injury.**

**WARNING! Even though your power chair is capable of climbing slopes greater than those illustrated in figure 1, do not, under any circumstances, exceed the incline guidelines or any other specifications presented in this manual. Doing so could cause instability in your power chair, resulting in personal injury and/or damage to your power chair.**

In compliance with the Americans with Disabilities Act of 1990, all handicap public access ramps are required to have a maximum slope of 5°. Therefore, Pride recommends that the maximum slope of an incline you attempt to safely ascend or descend on your power chair does not exceed 5°. See figure 1a.



**WARNING! Any attempt to climb or descend a slope steeper than 5° may put your power chair in an unstable position and cause it to tip, resulting in personal injury.**

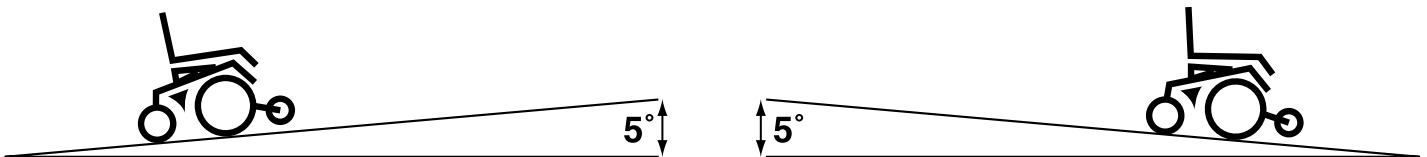

Figure 1. Maximum Safe Angle (Ascending and Descending)

### Braking Information

Your power chair is equipped with two powerful brake systems:

1. Regenerative — uses electricity to rapidly slow the vehicle when the joystick returns to the center/stop position.
2. Disc Park Brake — activates mechanically after regenerative braking slows the vehicle to near stop, or when power is removed from the system for any reason.



## II. SAFETY

### Cornering Information

While your power chair is equipped with rear caster wheels in back and anti-tip wheels in front, excessively high cornering speeds can still create the possibility of tipping. Factors which affect the possibility of tipping include, but are not limited to: cornering speed, steering angle (how sharply you are turning), uneven road surfaces, inclined road surfaces, riding from an area of low traction to an area of high traction (such as passing from a grassy area to a paved area – especially at high speed while turning), and abrupt directional changes. High cornering speeds are not recommended. If you feel that you may tip over in a corner, reduce your speed and steering angle (i.e., lessen the sharpness of the turn) to prevent your power chair from tipping.



**WARNING! When cornering sharply, reduce your speed. This greatly reduces the possibility of a tip or fall. To avoid personal injury and/or property damage, always exercise common sense when cornering.**

### Outdoor Driving Surfaces

Your power chair is designed to provide optimum stability under normal driving conditions—dry, level surfaces composed of concrete, blacktop, or asphalt. However, Pride recognizes that there will be times when you will encounter other surface types. For this reason, your power chair is designed to perform admirably on packed soil, grass, and gravel. Feel free to use your power chair safely on lawns and in park areas.

- Reduce your power chair's speed when driving on uneven terrain and/or soft surfaces.
- Avoid tall grass that can entangle the running gear.
- Avoid loosely packed gravel and sand.
- If you feel unsure about a driving surface, avoid that surface.

### Freewheel Mode

Your power chair is equipped with a manual freewheel lever to allow for manual maneuverability by a trained attendant. For more information about how to place your power chair into and out of freewheel mode, see IV. "The Jazzy 1104."



**WARNING! Do not use your power chair in freewheel mode without an attendant present. Personal injury may result.**

**WARNING! Do not attempt to personally place your power chair in freewheel mode while seated on it. Personal injury may result. Ask an attendant for assistance if necessary.**

**WARNING! Do not place your power chair in freewheel mode while on an incline. The chair could roll uncontrollably on its own, causing personal injury.**

### Stationary Obstacles (Steps, Curbs, etc.)

Proceed with extreme caution when driving near raised surfaces, unprotected ledges and/or drop-offs (curbs, porches, stairs, etc.). The correct method for approaching a curb is illustrated in figure 1b.

## II. SAFETY

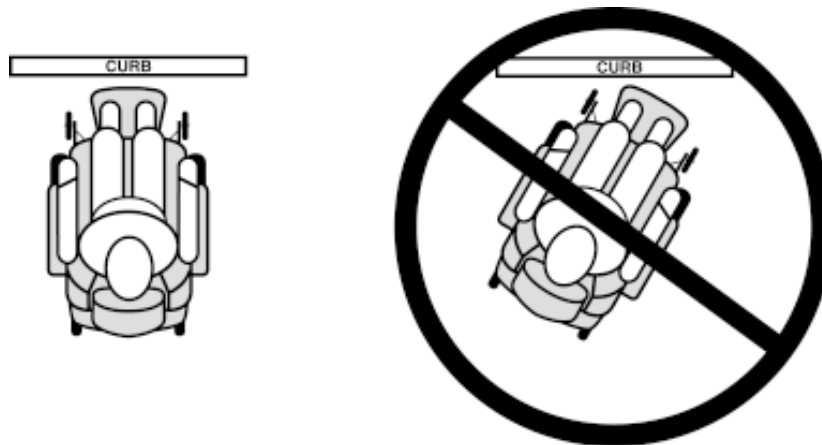

Figure 1a. Correct and Incorrect Curb Approach



**WARNING! Do not attempt to have your power chair climb or descend an obstacle that is higher than two inches unless you have the assistance of an attendant.**

**WARNING! Do not attempt to have your power chair proceed backward down any step, curb, or other obstacle. This may cause the power chair to tip and cause personal injury.**

### Public Streets and Roadways



**WARNING! You should not operate your power chair on public streets and roadways. Be aware that it may be difficult for traffic to see you when you are seated on your power chair. Obey all local pedestrian traffic rules. Wait until your path is clear of traffic, and then proceed with extreme caution.**

### Stairs and Escalators

Power chairs are not designed to travel up or down stairs or escalators. Always use an elevator.



**WARNING! Never use your power chair to negotiate steps or escalators. You may cause injury to yourself and to others and/or damage your power chair.**

### Doors

- Determine if the door opens toward or away from you.
- Drive your power chair gently and slowly forward to push the door open. Or drive your power chair gently and slowly backward to pull the door open.

## II. SAFETY

### Elevators

Modern elevators have a door edge safety mechanism that, when pushed, reopens the elevator door(s).

- If you are in the doorway of an elevator when the door(s) begin to close, push on the rubber door edge or allow the rubber door edge to contact the power chair and the door will reopen.
- Use care that pocketbooks, packages, or power chair accessories do not become caught in elevator doors.

### EMI & RFI

Laboratory tests performed by the Food and Drug Administration (FDA) have shown that radio waves can cause unintended motion of electric mobility vehicles. Radio waves are a form of electromagnetic energy (EM). When EM adversely affects the operation of an electronic device, it is called Electromagnetic Interference (EMI) or Radio Frequency Interference (RFI). For more information, see III. “EMI/RFI.”

### Lift/Elevation Products

If you will be traveling with your power chair, you may find it necessary to use a lift/elevation product to aid in transportation. Pride recommends that you closely review the instructions, specifications, and safety information set forth by the manufacturer of the lift/elevation product before using that product.

### Motor Vehicle Transport

Currently, there are no standards approved for tie-down systems in a moving vehicle of any type to transport a person while seated in a power chair.

### Transfers

Transferring onto and off of your power chair requires a good sense of balance. Always have an attendant or healthcare professional present while learning to properly transfer yourself.

To eliminate the possibility of injury, Pride recommends that you or a trained attendant perform the following tasks before attempting a transfer:

- Turn the power off. See VIII. “Operation.”
- Ensure your power chair is not in freewheel mode. See IV. “The Jazzy 1104.”
- Turn both caster wheels toward the transfer destination to improve power chair stability during transfer.
- Make sure both armrests are flipped up or removed from your power chair.
- Flip the footrest up, or move the leg rests aside; this will help to keep your feet from getting caught on the footrest or the leg rests during the transfer.
- Reduce the distance between your power chair and the object you are transferring onto.

**WARNING! Before transferring, position yourself as far back as possible in the power chair seat to prevent the power chair from tipping forward during transfer and causing injury.**



**WARNING! Avoid using your armrests for weight bearing purposes. Such use may cause the power chair to tip and cause personal injury.**

**WARNING! Avoid putting all of your weight on the footrest. Such use may cause the power chair to tip and cause personal injury.**

## II. SAFETY

### Positioning Belts

Your authorized Pride provider, therapist(s), and other healthcare professionals are responsible for determining your requirement for a positioning belt in order to operate your power chair safely.

**WARNING! If you require a positioning belt to safely operate your power chair, make sure it is fastened securely. Serious personal injury may result if you fall from the power chair.**



**WARNING! The positioning belt is not designed for use as a seat belt in a motor vehicle. Nor is your Jazzy suitable for use as a seat in any vehicle. Anyone traveling in a vehicle should be properly belted into seats approved by the vehicle manufacturer.**

**WARNING! Do not sit on your power chair while it is in a moving vehicle. Personal injury and/or property damage may result.**

**WARNING! Always be sure your power chair and its batteries are properly secured when it is being transported. Failure to do so may result in personal injury and/or damage to your power chair.**

### Inclement Weather Precautions



**WARNING! Pride recommends that you do not operate your power chair in icy or slippery conditions or on salted surfaces (i.e., walks or roads). Such use may adversely affect the performance and safety of your power chair, resulting in an accident and personal injury.**

**WARNING! Do not expose your power chair to any type of moisture at any time (rain, snow, mist, or wash). Such exposure can damage your power chair. Never operate your power chair if it has been exposed to moisture until it has dried thoroughly.**

### Reaching and Bending

Never reach, lean, or bend while driving your power chair. If it is absolutely necessary to reach, lean, or bend while seated on your power chair, it is important to maintain a stable center of gravity and keep the power chair from tipping. Pride recommends that the power chair user determine his/her personal limitations and practice bending and reaching in the presence of a qualified healthcare professional.



**WARNING! Do not bend, lean, or reach for objects if you have to pick them up from the floor by reaching down between your knees. Movements such as these may change your center of gravity and the weight distribution of the power chair. This may cause your power chair to tip, possibly resulting in personal injury. Keep your hands away from the tires when driving.**

### Batteries

In addition to following the warnings below, be sure to comply with all other battery handling information. For more information about your power chair's batteries, see IX. "Batteries and Charging."

## II. SAFETY

**WARNING! Power chair batteries are heavy. See specifications table. If you are unable to lift that much weight, be sure to get help. Lifting beyond your capacity can result in personal injury.**



**WARNING! Battery posts, terminals, and related accessories contain lead and lead compounds. Wash hands after handling.**

**WARNING! Always protect the batteries from freezing and never charge a frozen battery. Charging a frozen battery may result in personal injury and/or damage to the battery.**

### Preventing Unintended movement



**WARNING! If you anticipate being seated in a stationary position for an extended period of time, turn off the power. This will prevent unexpected motion from inadvertent joystick contact. This will also eliminate the possibility of unintended chair movement from electromagnetic (EM) sources. Failure to do so may result in personal injury.**

### Prescription Drugs/Physical Limitations

Users must exercise care and common sense when operating a power chair. This includes awareness of safety issues when taking prescribed or over-the-counter drugs or when the user has specific physical limitations.



**WARNING! Consult your physician if you are taking prescribed or over-the-counter medication or if you have certain physical limitations. Some medications and limitations may impair your ability to operate your power chair in a safe manner.**

### Alcohol

The power chair user must exercise care and common sense when operating his/her power chair. This includes awareness of safety issues while under the influence of alcohol.



**WARNING! Do not operate your power chair while you are under the influence of alcohol, as this may impair your ability to operate your power chair in a safe manner.**

### Removable Parts



**WARNING! Do not attempt to lift or move a power chair by any of its removable parts. Personal injury and/or damage to the power chair may result.**

## III. EMI / RFI

Laboratory tests performed by the Food and Drug Administration (FDA) have shown that radio waves can cause unintended motion of power chairs. Radio waves are a form of electromagnetic energy (EM). When this energy adversely affects the operation of an electronic device, it is called *Electromagnetic Interference (EMI) or Radio Frequency Interference (RFI)*.



**WARNING! Radio waves may interfere with the control of power chairs.**

### **EMI/RFI—FREQUENTLY ASKED QUESTIONS (FAQs)**

The following FAQs summarize what you should know about EMI/RFI. Use this information to minimize the risk that EMI/RFI will affect your power chair.

#### **Where do radio waves come from?**

Radio waves are emitted from the antennas of cellular phones, mobile two-way radios (such as walkie-talkies), radio stations, TV stations, amateur radio (HAM) transmitters, wireless computer links, microwave sources, and paging transmitters. Radio waves are a form of EM. Because electromagnetic energy is more intense closer to the transmitting antenna (source of emission), the EM fields from two-way radios are of special concern to power chair users.

#### **If my power chair is affected by EMI/RFI, what kind of motion should I expect?**

This is hard to predict. It would depend on a number of factors:

- Strength of the radio waves
- Construction of the power chair
- Position of the power chair (whether it is on level ground or on an incline)
- Whether or not the power chair is in motion

An affected power chair's movement can be erratic. It may move by itself or come to a sudden stop. Furthermore, it is possible for EMI/RFI to unexpectedly release the brakes on a power chair. Some intense sources of EMI/RFI can even damage the control system of your Jazzy.

#### **Is there any way to know for sure whether radio waves are responsible for the unintended motion of my power chair?**

Unfortunately, interference from radio wave sources may be difficult to recognize, since the signals from these sources are invisible and may be intermittent. However, the FDA recommends that you report all incidents of unintended motion or brake release to the power chair manufacturer and, if possible, note whether there was a radio wave source nearby at the time of the incident.

#### **Has anyone been hurt from erratic, unintended motion of power chairs?**

The FDA has reports of injuries that resulted from the apparent uncontrolled motion of power chairs. However, it is unclear how many of these incidents were actually caused by radio wave interference.

## III. EMI/RFI

### **Are all power chairs susceptible to EMI/RFI?**

Each make and model of chair differs in its ability to resist electromagnetic interference. That is, each has a particular level of “immunity” to interference, measured in volts per meter (V/m). A higher immunity level offers greater protection. In other words, a power chair with a high immunity level is less likely to be affected by a strong radio source than one with a low immunity level.

### **What is the FDA doing about the problem?**

The FDA has written power chair manufacturers and requested that they test their new products to be sure that they provide a reasonable degree of immunity against EMI/RFI. The letter states that power chairs should have an immunity level of at least 20 V/m. This provides a reasonable degree of protection against the common sources of EMI/RFI.

The FDA has also requested that these manufacturers clearly label their products with the immunity level, or state that the immunity level is not known. The labeling and informational material supplied with the power chair must explain what the immunity level means, and the labeling or informational material must warn users about the possibility of EMI/RFI and how to avoid it. In addition, the FDA has recommended that manufacturers establish an educational program to inform power chair users and their caregivers about the problems associated with EMI/RFI, and the actions they can take to minimize the risk. The FDA requested that power chair manufacturers have these actions implemented by December 2, 1994.

### **What can I do to find out if my power chair is likely to be affected by EMI/RFI?**

If you've had your power chair for a long time and haven't experienced any unintended motion, it is not likely that you will have problems in the future. But it is always possible that problems could arise if you are close to a source of radio waves. Therefore, it is very important to be alert to this possibility. The Jazzy 1104 meets or exceeds an immunity level of at least 20 V/m.

### **What can I do to reduce the risk that my power chair could be affected by EMI/RFI?**

Here are some precautions you can take:

- Do not turn on or use hand-held personal communications devices, such as citizens band (CB) radios and cellular phones, while the power chair is on.
- Be aware of nearby transmitters, such as radio or TV stations and hand-held or mobile two-way radios, and try not to come close to them. For example, if you are in a power chair with an immunity level of 20 V/m, you should remain at least three feet from a hand-held two-way radio and ten feet from a mobile two-way radio.
- Be aware that adding accessories and/or components, or modifying the power chair, may make it more susceptible to interference from radio wave sources. There is no easy way to evaluate their effect on the overall immunity of the power chair.

### **What should I do if my power chair moves unexpectedly?**

If unintended motion or brake release occurs, turn the power chair off as soon as it is safe to do so.

### **If my power chair moves unexpectedly, where should I report this?**

Call Pride at 1-800-424-8205 to report the incident.

# IV. THE JAZZY 1104

## THE JAZZY 1104

Your Jazzy 1104 has two main assemblies: the seat and the power base. See figures 1b and 2. There are a variety of seating options that are designed to accommodate most users. Typically, the seating assembly includes the armrests, seat back, seat base, and joystick controller. Your Jazzy seat may also have some optional accessories attached to it, such as a basket, a cane/crutch holder, a cup holder, or a power seat switch. See XI. "Optional Accessories" in this manual.

The power base is the heart of your Jazzy 1104. The power base assembly includes a frame, two drive wheels, two anti-tip wheels, two rear caster wheels, and a body shroud.



Figure 2. The Jazzy 1104



# IV. THE JAZZY 1104



Figure 2. Rear View

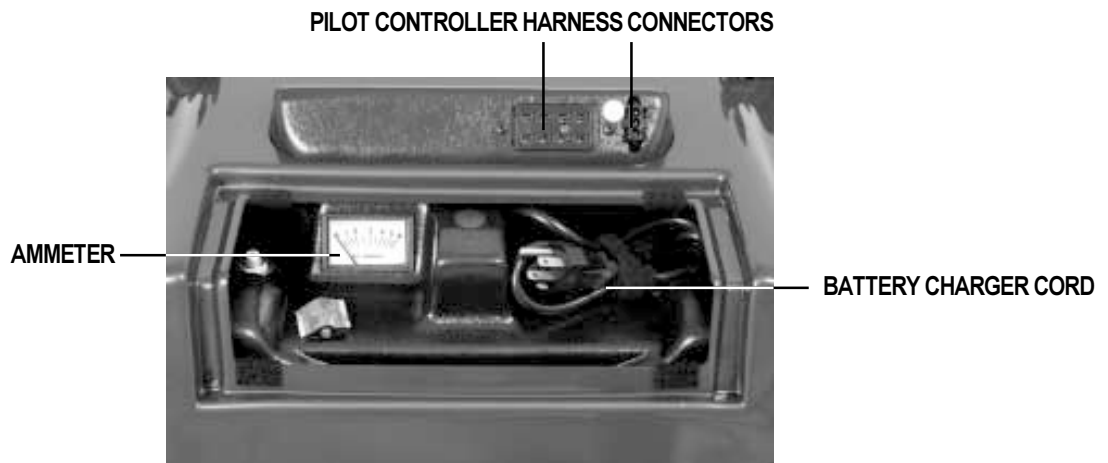

Figure 3. Utility Tray

# IV. THE JAZZY 1104

## ELECTRONICS TRAY

The electronics tray is located on the rear of your Jazzy. See figure 3. A section of the electronics tray is exposed through the body shroud. The rest of the electronics tray is located underneath the rear door. The electronics tray consists of the ammeter, the battery charger cord, the main circuit breaker, the lighting harness connectors (optional equipment), and the controller harness connectors.

- **Ammeter:** The ammeter displays the charger's current output in amps. See figure 3. For more information, see IX. "Batteries and Charging" in this manual.
- **Battery Charger Cord:** This cord is used whenever your battery needs recharging. See figure 3.
- **Main Circuit Breaker:** The main circuit breaker is a safety feature built into your Jazzy 1104. See figure 4. When the batteries and the motors are heavily strained (e.g., from excessive loads), the main circuit breaker trips to prevent damage to the motors and the electronics. If the circuit trips, allow your Jazzy to "rest" for approximately one minute. Next, push down the circuit breaker button, turn on the joystick controller and continue normal operation. If the main circuit breaker continues to trip repeatedly, contact your authorized Pride provider.
- **Lighting Harness Connector (Optional):** This is where the optional lighting harness connects to the controller. See figure 5.
- **Controller Harness Connectors:** This is where the joystick connects to the motors, batteries, and charger. Your Jazzy is equipped with a Pilot controller. There are two connectors on the tray. See figure 3.
- **Power Seat Connector:** This is for the optional power seat switch. (Not shown.)

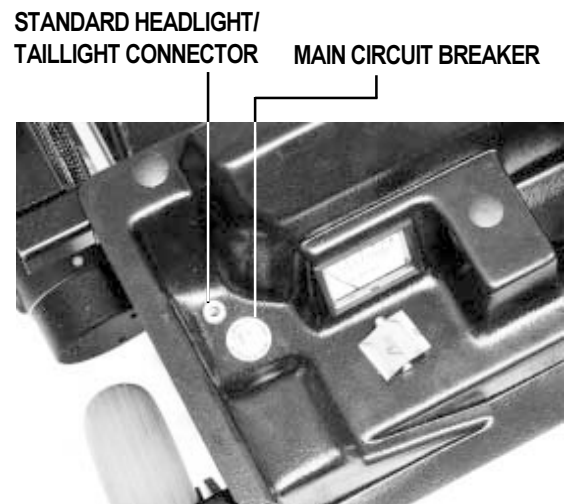

Figure 4. Main Circuit Breaker



Figure 5. Full Lighting Harness Connector

# IV. THE JAZZY 1104

## FREEWHEEL LEVERS

For your convenience, your Jazzy 1104 is equipped with two freewheel levers. See figures 6 and 7. These levers allow you to disengage the drive motors and maneuver the chair manually.



**WARNING! DO NOT use your Jazzy 1104 while the drive motors are disengaged unless you are in the presence of an attendant! DO NOT disengage the drive motors when your Jazzy 1104 is on an incline. The chair could roll down on its own, causing injury!**

**To engage or disengage the freewheel feature:**

1. Turn the freewheel levers outward to disengage the drive motors. See figure 6.
2. Turn the freewheel levers inward, to engage the drive motors. See figure 7.



**CAUTION! It is important to remember that when your Jazzy 1104 is in freewheel mode, the braking system is disengaged.**

If a lever is difficult to move in either direction, rock your Jazzy 1104 back and forth slightly. The lever should then move to the desired position.

FREEWHEEL LEVERS

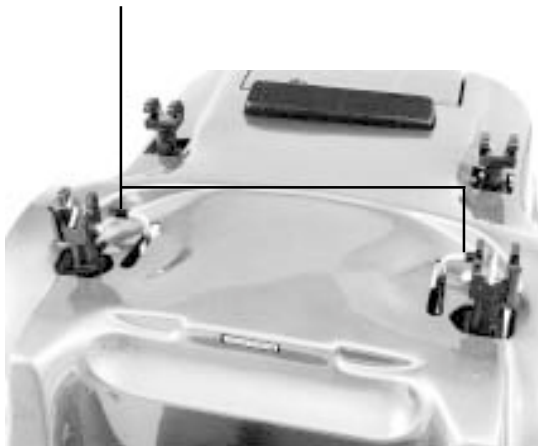

Figure 6. Drive Disengaged

FREEWHEEL LEVERS



Figure 7. Drive Engaged

# IV. THE JAZZY 1104

SPECIFICATIONS	
Suspension:	Limited suspension
Drive Wheels:	14 in., pneumatic (solid tires are optional)
Rear Casters:	8 in., solid, rear articulating
Anti-tip:	6 in., solid, front mounted
Maximum Speed:	Up to 4.5 mph
Brakes:	“Intelligent Braking,” electronic regenerative, disc park brake
Ground Clearance:	3.5 in.
Turning Radius:	19.5 in.
Overall Size:	Length: 39.5 in. Width: 25.4 in.
Seating Options:	Medium-back High-back with headrest
Drive Train:	Two motor, mid wheel
Batteries:	Two 12-volt, Group 24 batteries
Range:	Up to 25 miles
Battery Charger:	Onboard Off-board (optional)
Electronics:	50-amp P & G Pilot Controller
Weight Capacity:	250 lbs.
Jazzy Weights:	Base: 81 lbs. Seat: 29 lbs. Batteries: 48 lbs.
Warranty:	Lifetime limited warranty on frame Two-year warranty on electronics Eighteen-month warranty on drive motor

# V. ASSEMBLY

To reduce the possibility of shipping damage, your Jazzy 1104's seat is removed from the power base, and the seat back is removed from the seat assembly before your Jazzy is shipped. The joystick may also have been removed from the armrest. The following is a set of instructions to help you quickly and easily prepare your Jazzy 1104 for immediate use.



**WARNING!** Do not pick up the seat frame by the armrests. They are free to pivot, and you may lose control of the seat if they do so, resulting in personal injury or damage to the chair.



**CAUTION!** Do not place the controller cable so that it can be pinched in the seat frame or the power base frame.

**Required Tool:** Phillips screwdriver

Parts List	Quantity
Phillips-head seat back mounting screws	4
Seat back	1
8-in. wire ties	4

## SEAT BACK ASSEMBLY

The seat back mounts to the back hinges with four (4) Phillips-head screws. You may install the seat back before or after you install the seat to the power base.

### To mount the seat back to the hinge:

1. Line up the hinges with the holes in the seat back. See figure 8.
2. Insert the seat back mounting screws through the hinge and into the seat back.
3. Tighten the four screws.

## SEAT INSTALLATION (SEAT WITH H-FRAME)

The standard seat installation method incorporates the seat frame (H-frame) and four (4) adjustable seatposts located on the powerbase.

ATTACH SEAT BACK HERE

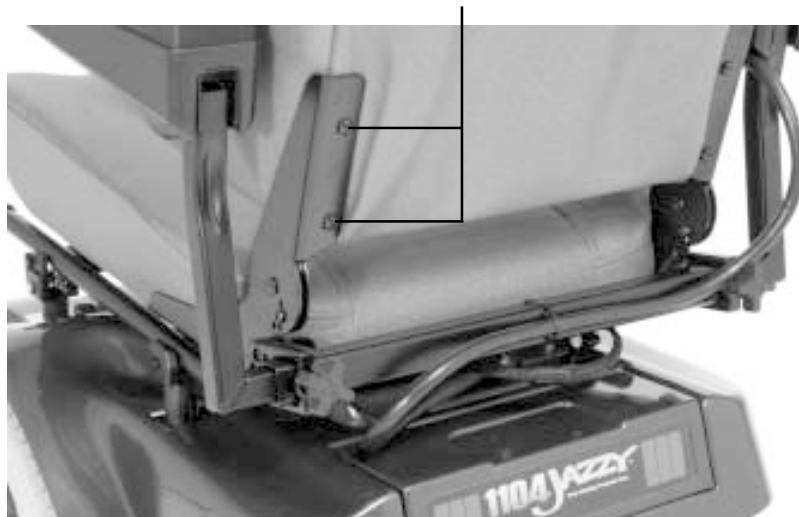

Figure 8. Seat Back Assembly

# V. ASSEMBLY

## To install the seat:

1. Set the seat on the rear seat towers. See figure 9.
2. Push the seat back and down until the latches engage on the front seat towers. See figure 10.
3. Plug the controller cable into the connector on the utility tray. See figure 11.
4. Plug the power seat switch cable (if so equipped) into the connector on the utility tray.
5. Secure the controller cable to the armrest receiver with one or more wire ties.
6. Route the cable to ensure that the cable cannot be pinched in the seat hinge.

## JOYSTICK INSTALLATION

Depending on the various configurations and options you have chosen for your Jazzy, it may have been shipped without the joystick installed in the armrest.

## To install the joystick:

1. Use a 3/16-in. hex wrench to loosen the setscrew. See figure 12.
2. Slide the joystick mounting bracket into or out of the armrest to the desired position.
3. Retighten the setscrew by turning it clockwise.

SLIDE SEAT ONTO TOWERS

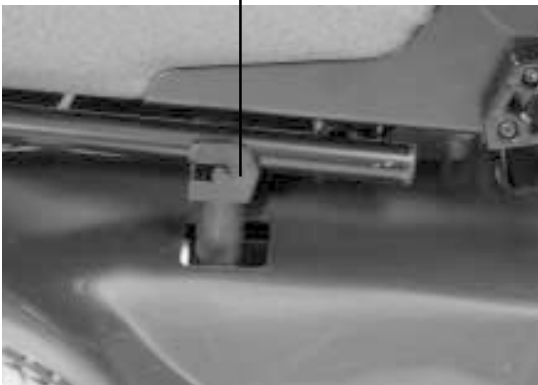

Figure 9. Rear Towers

LOCK SEAT INTO PLACE HERE

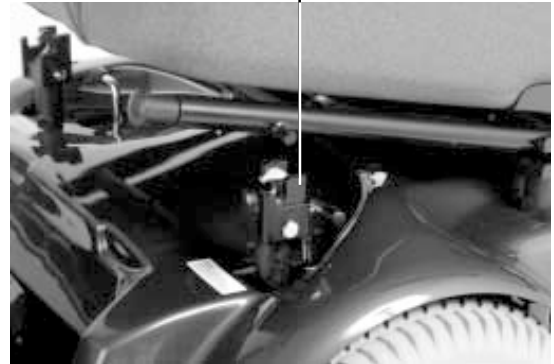

Figure 10. Front Towers

PLUG IN CONTROLLER CABLE



Figure 11. Controller Cable

SLIDE JOYSTICK  
INTO BRACKET

SETSCREW

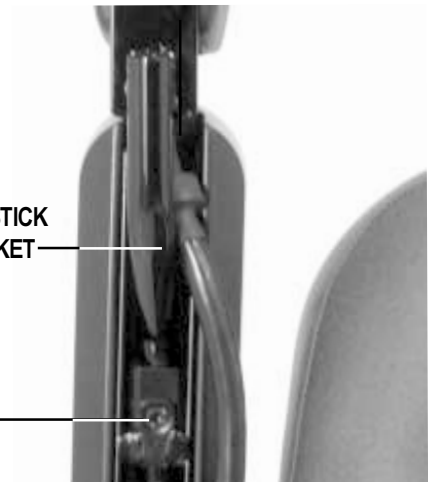

Figure 12. Joystick

# VI. COMFORT ADJUSTMENTS

Once you are familiar with your Jazzy's operation, you may find the need to adjust your seating position. There are some adjustments you can make to increase your comfort, such as seat height and angle, armrest height and angle, footrest height and angle, and joystick position.



**WARNING!** If your Jazzy 1104 was configured at your authorized Pride provider or service center, please consult your health care professional before changing the seat position or making any other adjustment. Some adjustments may degrade your Jazzy's performance and safety by changing its center of gravity.

## SEAT HEIGHT AND ANGLE

You can change the seat height by one of two ways: either manually or automatically.

### To change the seat height:

1. Remove the seat. See VII. "Disassembly" in this manual.
2. Remove the shroud.
3. Remove the ball detent pin from each seat tower. See figure 13.
4. Raise or lower each seat tower to the desired position.
5. Install the ball detent pin into each seat tower.
6. Reinstall the shroud.
7. Install the seat.

### To change the seat angle:

You can change the seat angle by either raising or lowering only one set of seat towers (front or rear).

## ARMREST WIDTH

### To change the armrest width:

1. Locate the two knobs on the armrest receiver bracket. See figure 14.
2. Loosen the knobs and slide the armrests in or out to the desired width.
3. Tighten the knobs.

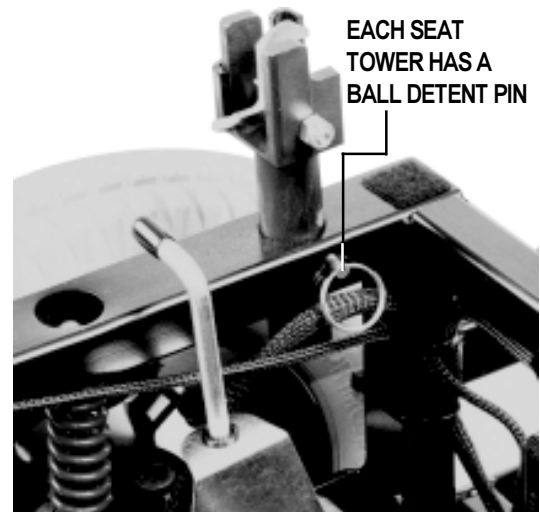

Figure 13. Seat Tower Ball Detent Pin

LOOSEN KNOBS TO MOVE ARMREST



Figure 14. Armrest Width

TURN THIS SCREW TO CHANGE ARMREST ANGLE

JAM NUT LOCKS ADJUSTMENT SCREW IN PLACE

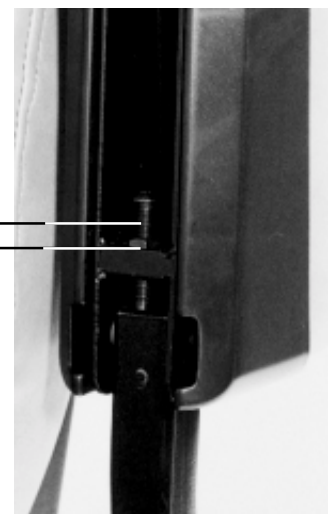

Figure 15. Armrest Angle Adjustment

# VI. COMFORT ADJUSTMENTS

## ARMREST ANGLE

You can adjust the armrest angle to fit your specific needs.

### To change the armrest angle:

1. Lift the armrest straight up so that it is perpendicular to the floor.
2. Use a 7/16-in. wrench to loosen the jam nut. See figure 15.
3. Use a 5/32-in. hex key to loosen the adjusting screw.
4. Turn the screw clockwise to lower the front of the armrest, or turn the screw counterclockwise to raise the front of the armrest.
5. Lock the adjusting screw into place by tightening the jam nut.

## ARMREST HEIGHT (OPTIONAL)

Your Jazzy may be equipped with height-adjustable armrests.

### To change the armrest height:

1. Loosen the setscrew located underneath the armrest using a 3/16-in. hex wrench.
2. Remove the ball detent pin from the armrest.
3. Move the armrest up or down to the desired height.
4. Align the holes and reinsert the ball detent pin.
5. Retighten the setscrew.

## JOYSTICK EXTENSION

The joystick control can easily slide out away from the armrest or in toward the armrest.

### To extend the joystick:

1. Use a 3/16-in. hex wrench to loosen the setscrew. See figure 16.
2. Slide the joystick mounting bracket into or out of the armrest to the desired position.
3. Tighten the setscrew by turning it clockwise.

## SWING-AWAY JOYSTICK

Your Jazzy may be equipped with a swing-away joystick. This option enables you to move the joystick from the front of the armrest to the side of the armrest, without disconnecting it. See figures 17 and 18.

## JOYSTICK POSITION

The standard joystick can be mounted to the left or right side of your Jazzy. Contact your authorized Pride provider.

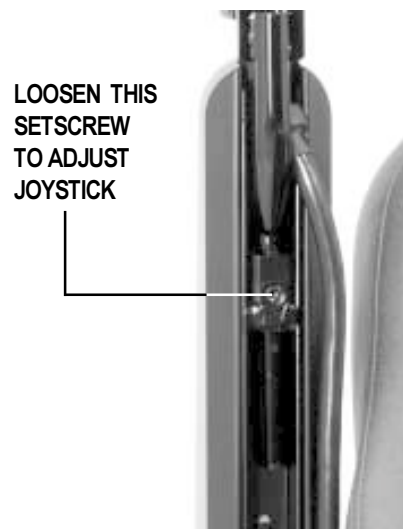

Figure 16. Joystick Extension



Figure 17. Swing-away Joystick (Forward Position)



Figure 18. Swing-away Joystick (Retracted Position)



# VI. COMFORT ADJUSTMENTS

## FOOTREST HEIGHT

The footrest height is easily adjusted to one of six different heights in one-inch increments.

### To raise or lower the footrest:

1. Remove the two 7/16-in. bolts and their nuts from the footrest. See figure 19.
2. Raise or lower the footrest to the desired height.
3. Install the two 7/16-in. bolts and nuts into the footrest and tighten.

## FOOTREST ANGLE

You can adjust the angle of the footrest with a 3/16-in. hex wrench. See figure 20.

### To adjust the footrest angle:

1. Turn the setscrew clockwise to raise the front of the footrest.
2. Turn the setscrew counterclockwise to lower the front of the footrest.

## SWING-AWAY FOOTRESTS OPTION

Swing-away footrests (SFRs) are an option. They enable you to swing the leg rest to the side before transferring from your Jazzy.

### To swing the leg rests:

1. Push in the release lever. See figure 21.
2. Swing the footrest off to the side.

REMOVE THESE NUTS AND BOLTS  
TO RAISE OR LOWER THE FOOTREST

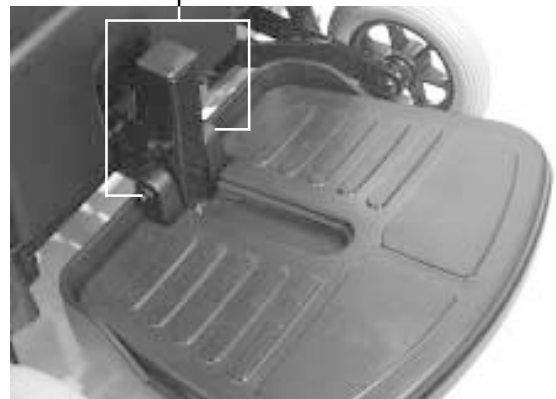

Figure 19. Footrest Height

TURN SETSCREW TO CHANGE FOOTREST ANGLE



Figure 20. Footrest Angle

SFR RELEASE LEVER



Figure 21. Swing-away Footrests

# VI. COMFORT ADJUSTMENTS

## ELEVATING LEG RESTS OPTION

Elevating Leg Rests (ELRs) offer an infinite range of adjustment between 0 and 70 degrees for the leg angle and a footrest adjustment range of 15 – 20 in.

### To adjust the ELR angle:

1. Press the release lever. See figure 22.
2. Move the leg rest to the desired angle.

### To adjust the ELR footrest height:

1. Remove the two screws from the side of each leg rest extension. See figure 23.
2. Loosen the bolt on the side of each leg rest extension.
3. Slide the leg rest in or out to the desired length.
4. Tighten the bolt and reinstall the two screws on each leg rest extension.

## HIGH BACK WITH HEADREST OPTION

If your Jazzy is equipped with the deluxe high-back seat, you can adjust the headrest height.

### To adjust the headrest height:

1. Push in the headrest release button.
2. Move the headrest up or down to the desired position.

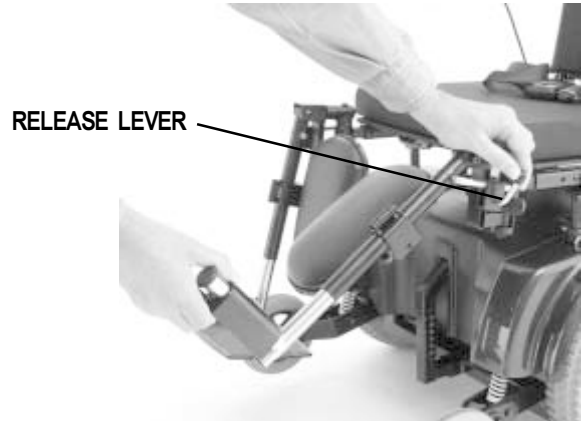

Figure 22. Elevating Leg Rests

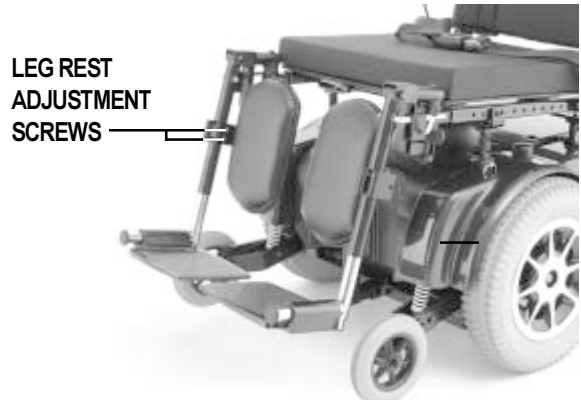

Figure 23. Elevating Leg Rests

# VII. DISASSEMBLY

## SEAT REMOVAL

You may wish to remove the seat for transportation. If you have a Versa Seat, please refer to the Versa Seat Installation and Adjustment guide.

### To remove the seat:

1. Turn the power off.
2. Make sure your Jazzy is not in freewheel mode.
3. Unplug the main wire harness behind the seat.
4. Simultaneously depress the two plungers on the front of the seat frame while lifting the front of the seat. See figure 24.
5. Lift the seat up and gently lower it back onto the front seat towers.
6. Pull the seat forward and lift it off of the rear seat towers.



Figure 24. Removing The Seat

## BODY SHROUD REMOVAL

The body shroud is a one-piece, molded plastic body that covers the power base frame. It helps protect the Jazzy components from the environment. It also provides mounting points for lights and the standard light switch. You must remove the body shroud in order to change the batteries and check the cable connections.

### To remove the body shroud:

1. Turn the power off.
2. Make sure your Jazzy is not in freewheel mode. See IV. “The Jazzy 1104.”
3. Unplug the controller wiring harness.
4. Remove the seat.
5. Disconnect the lighting harness (if your Jazzy is equipped with lights).
6. Lift the body shroud straight up. The body shroud is attached to the metal frame by reusable fasteners. The body shroud should lift up easily.



**WARNING! Your Jazzy 1104 batteries are heavy. Refer to the specifications table. If you are unable to lift that much weight, be sure to get help. Lifting beyond your capacity can result in personal injury.**

## BATTERY REMOVAL

### To remove the batteries:

1. Turn the power off.
2. Remove the body shroud.
3. Remove the battery post caps (both red and black).
4. Unscrew the wing nuts on (+) red battery terminals, one at a time.
5. Remove the (+) red battery cables from the battery posts; be sure to secure the terminals away from the batteries.
6. Loosen the wing nuts on (-) black battery terminals.
7. Remove the (-) black cables and secure the terminals away from the batteries.
8. You can now remove the batteries from your Jazzy 1104.

# VIII. OPERATION

## PILOT CONTROLLER

The electronic controller is what you use to operate your power chair. It takes the battery voltage and sends it to the appropriate system. The electronic controller also enables you to monitor battery charge, electronic controller functions, and the condition of your electrical system. Also, it may be used to control some optional systems such as power elevating seats and lights.

The Pilot electronic controller is an integral electronic controller. All of the electronics necessary to operate the power chair are contained in one module. See figure 25.

The Pilot consists of:

1. joystick
2. on/off button
3. battery condition meter
4. speed control knob
5. off-board charger/programming socket
6. controller connector
7. 3-pin charger inhibit connector

Typically, the Pilot is mounted to one of the armrests and is connected to the motors, batteries, and the onboard charger at the electronics tray.

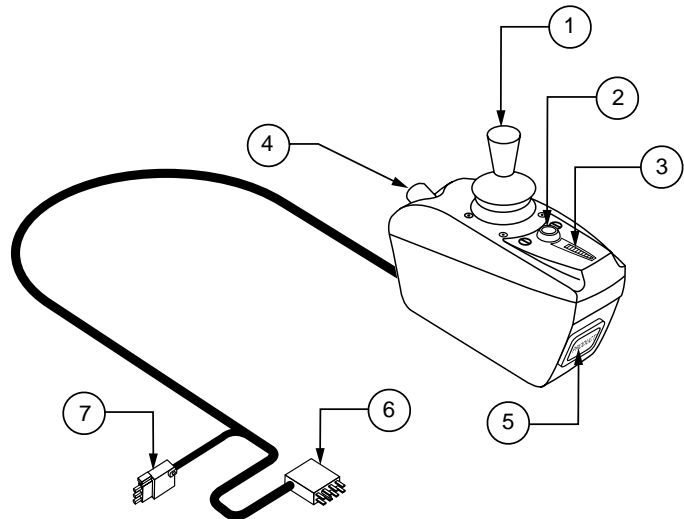

Figure 25. Pilot Controller

## Joystick

The joystick controls the direction and speed of your power chair. When you move the joystick from the neutral (center) position, the electromagnetic brakes release and allow your power chair to move. The further you push the joystick from its neutral position, the faster your power chair moves. When you release the joystick and allow it to return to the neutral position, you engage the electromagnetic brakes. This causes your power chair to decelerate and come to a complete stop.



**WARNING! If your power chair begins to move in an unexpected manner, immediately release the joystick. Unless the joystick is damaged, this action should stop your power chair.**

## On/Off Button

This is a green button located in front of the joystick. It turns the Pilot on and off.



**WARNING! Unless faced with an emergency situation, do not use the on/off push button to stop the chair. This will cause the power chair to stop abruptly.**

**WARNING! Always turn the power off when you are stationary to prevent unexpected movement.**

# VIII. OPERATION

## Battery Condition Meter

The battery condition meter is located in front of the joystick. This is a 10-segment illuminated display that indicates that the Pilot is turned on and also gives the battery status, the Pilot status, and the electrical system status.

- **Red, yellow, and green lights lit:** Battery charged; Pilot and electrical system OK.
- **Red and yellow lights lit:** Charge battery if possible; Pilot and electrical system OK.
- **Red lights only lit or slow flash:** Charge battery as soon as possible; Pilot and electrical system OK.
- **Rapid flash of lights:** Indicates a fault in the Pilot or the electrical system. Refer to “Trouble Codes.”
- **Ripple up and down of lights:** The joystick was not in the neutral position when the controller was turned on. If you get “ripple up and down of lights”, turn off the controller, allow the joystick to return to the neutral position, then turn on the controller.

*NOTE: If you still get “ripple up and down of lights”, contact your authorized Pride Provider.*

*NOTE: When the batteries approach a discharged state, the first red light will begin to slowly flash, reminding you the batteries need to be charged immediately!*

## Speed Control Knob

Sets the maximum speed of the power chair: clockwise to increase, counterclockwise to decrease.

*NOTE: We recommend that the first few times you operate your power chair, you turn the speed control to the slowest setting until you become familiar with your new power chair.*

## Off-board Charger/Programming Socket

You may use an off-board charger to charge the power chair batteries through the 3-pin socket located on the front of the Pilot. If you use an off-board charger, the charger current should not exceed 12 amps. Contact your authorized Pride provider for more information.



**CAUTION! Only chargers with Neutrik NC3MX plugs should be connected to the offboard charger/programming socket. See your authorized Pride provider for more information.**

*NOTE: The offboard charger/programming socket may also be used for reprogramming the Pilot. Contact your authorized Pride provider for more information.*

## Controller Connector

This connects the Pilot to the power chair’s batteries, motors, and motor brakes.

# VIII. OPERATION

## 3-pin Charger Inhibit Connector

This connects the Pilot to the onboard battery charger. This connection provides an inhibit that disables the Pilot when the battery charger is on. The charger inhibit connector is coded with colored dots. The dots are positioned so that you align the flat side of the male connector with the flat side of the female connector before making the connection.



**CAUTION! Failure to properly align the connectors can result in damage to the Pilot, the charger harness, and the connectors.**

## Thermal Rollback

The Pilot is equipped with a thermal rollback circuit. This circuit monitors the temperature of the motors and the Pilot. In the event that either one of the motors or the Pilot becomes excessively hot (above 122° F), the Pilot reduces the motor voltage. For every degree above 122° F, the controller reduces the voltage by 5 volts. This reduces your power chair's speed and allows the electrical components to cool down. When the temperature returns to a safe level, your power chair resumes its normal speed.



**WARNING! Under strenuous driving conditions, it is possible for the bottom and side case temperature of the Pilot to exceed 105° F. DO NOT touch the side or bottom of the Pilot case under these circumstances.**

## Trouble Codes

In addition to indicating the current state of battery charge, the battery condition meter can also indicate possible problems with your power chair. The battery condition meter has ten lights. The lights provide information by the number of lights that are flashing. If any of the meter lights are flashing rapidly, the controller may be indicating a fault. For instance, if the first light is flashing rapidly, the battery voltage is nearly depleted. The following is a list of the possible errors signified by the rapidly flashing meter. When you get a trouble code, contact your authorized Pride provider.

FLASHING LIGHTS	DIAGNOSIS	SOLUTION
10	High Battery Voltage	Check batteries.
9	Solenoid Brake Fault	Check motor/brake wiring.
8	Possible Controller Fault	See authorized Pride provider.
7	Possible Joystick Fault	See authorized Pride provider.
6	Inhibit Active	Unplug charger. Check connections.
5	Right Motor Wiring Fault	Check right motor wiring.
4	Right Motor Disconnected	Check right motor wiring.
3	Left Motor Wiring Fault	Check left motor wiring.
2	Left Motor Disconnected	Check left motor wiring.
1	Low Battery Voltage	Check batteries/battery wiring.

# IX. BATTERIES AND CHARGING

## BATTERIES

Your Jazzy 1104 uses two long-lasting, 12-volt batteries. These batteries are sealed, maintenance free, deep-cycle batteries. Since they are sealed, there is no need to check the electrolyte (fluid) level. Deep-cycle batteries are designed to handle a longer and deeper discharge. Though they are similar in appearance to automotive batteries, they are not interchangeable. Automotive batteries are not designed to handle a long, deep discharge and also are unsafe for use in power chairs.



**WARNING! Battery posts, terminals and related accessories contain lead and lead compounds. Wash hands after handling.**

## CHARGING THE BATTERIES

The battery charger is essential in providing long life for your Jazzy 1104 batteries. See figure 26. The battery charger is designed to optimize your Jazzy 1104's performance by charging the batteries safely, quickly, and easily. The charging system consists of the charger, the charger fuse, and the ammeter. See figures 26 and 27. The onboard charger is located underneath the electronics tray. The ammeter is located on the utility tray for easy viewing. The charger has an in-line fuse that protects the system. The ammeter indicates the rate of charge necessary to fully recharge the batteries. It is also a good indication of whether or not the charger is working. The ammeter and the charger are only functional when the charger power cord is plugged into a wall outlet. The Jazzy will not operate when the charger is plugged into the wall outlet.

**WARNING! Never use an extension cord to plug in your battery charger. Plug the charger directly into a properly wired standard wall outlet.**



**WARNING! You must recharge your Jazzy's batteries with the supplied onboard or off-board charging system. Do not use an automotive-type battery charger.**

**WARNING! Always protect batteries from freezing temperatures and never charge a frozen battery. This damages the battery and may cause personal injury. Attempting to charge a battery in freezing conditions does not prevent a battery from freezing.**



**CAUTION! Only chargers with Neutrik NC3MX plugs should be connected to the off-board charger/programming socket. See your authorized Pride provider for more information.**

BATTERY CHARGER

CHARGER FUSE



Figure 26. Onboard Battery Charger

AMMETER



Figure 27. Electronics Tray

# IX. BATTERIES AND CHARGING

## **To charge the batteries using the onboard battery charger:**

1. Position the rear of your Jazzy 1104 close to a standard wall outlet.
2. Be certain the controller power is turned off and the freewheel levers are in the engaged position. See IV. "The Jazzy 1104" in this manual.
3. Lift off the rear cover.
4. Extend the charger power cord and plug it into the wall outlet. The Jazzy 1104 incorporates an inhibit function that disables the power chair when the charger is plugged into a wall outlet.
5. The ammeter indicates how much charge is needed to fully charge the batteries. Wait about a minute for the charger to warm up. The ammeter may move as high as 5.5 amps, then gradually move back down to 0 amps as the batteries charge.
6. We recommend you charge the batteries for 8 to 14 hours. As the batteries charge, the ammeter needle slowly drops to zero. When the batteries are fully charged, the needle vibrates on or near the zero mark on the ammeter scale.
7. When your Jazzy 1104's batteries are fully charged, you can unplug the power cord from the wall outlet, wind it up using the hook and loop strap, and place the cord back into the rear tray.
8. Secure the rear cover.

## **OFF-BOARD CHARGER**

### **If your Jazzy is equipped with an off-board charger, follow these instructions:**

1. Position your Jazzy next to a standard wall outlet.
2. Be certain the controller power is turned off.
3. Remove the run plug located on the utility tray. This activates the inhibit function.
4. Plug the 3-pin extension cable into the charger, then into the utility tray connector.
5. Plug the charger into the wall outlet.
6. The ammeter indicates how much charge is needed to fully charge the batteries. Wait about a minute for the charger to warm up. The ammeter should move all the way up to 5 amps, then gradually move back down to 0 amps.
7. We recommend you charge the batteries for 8 to 14 hours. As the batteries charge, the ammeter needle slowly drops to zero. When the batteries are fully charged, the needle vibrates on or near zero on the ammeter scale.
8. When your Jazzy 1104's batteries are fully charged, disconnect the charger cord from the wall outlet.
9. Disconnect the charger from the rear utility tray.
10. Reconnect the run plug into its connector.

*Note: If the run plug is not reconnected, your Jazzy will not run.*

11. Replace the rear cover.

## **BATTERY BREAK-IN**

### **To break in new batteries for maximum efficiency:**

1. Fully recharge any new battery prior to its initial use. This brings the battery up to about 90% of its peak performance level.
2. Operate your Jazzy 1104 about the house and yard. Move slowly at first, and don't stray too far until you become accustomed to the controls and break in the batteries.



# IX. BATTERIES AND CHARGING

3. Give the batteries another full charge of 8 to 14 hours and operate your Jazzy 1104 again. The batteries should now perform at over 90% of their potential.
4. After four or five charging cycles, the batteries top off at 100% charge and last for an extended period.

## **BATTERIES AND CHARGING—FREQUENTLY ASKED QUESTIONS (FAQS)**

### **How does the charger work?**

The battery charger takes the standard wall outlet voltage of 120 VAC (alternating current) and converts it to 24 VDC (direct current). The Jazzy 1104 batteries use direct current to run your power chair. When the battery voltage is low, the charger works harder to charge the battery. This is why the charging ammeter initially reads 5 or more amps. As the battery voltage approaches full charge, the charger doesn't work as hard to complete the charging cycle. This explains why the charging ammeter drops as it approaches a full charge. When the battery is fully charged, the amperage from the charger is nearly at zero. This is how the charger maintains a charge but does not overcharge the battery.

### **Can I use a different battery charger?**

You should use the charger supplied with the Jazzy 1104. It is the safest, most efficient tool to charge the batteries. We do not recommend using other types of chargers (e.g., an automotive battery charger). Your Jazzy 1104's charger will not operate after the batteries have been discharged to nearly zero voltage. If this happens, call your local authorized provider for assistance.

### **How often must I charge the batteries?**

Many factors come into play when deciding how often to charge the batteries. You may use your Jazzy 1104 all day on a daily basis or you may not use it for weeks at a time.

#### **■ Daily Use**

If you use your Jazzy 1104 on a daily basis, charge the batteries as soon as you are finished. Your Jazzy 1104 will be ready each morning to give you a full day's service. It is recommended that you charge the batteries 8 to 14 hours after daily use. Do not charge the batteries for more than 24 hours at a charging cycle.

#### **■ Infrequent Use**

If you use your Jazzy 1104 infrequently (once a week or less), you should charge the batteries at least once per week for 12 to 14 hours.

*Note: Keep your batteries fully charged and avoid deeply discharging your batteries. Do not charge the batteries for more than 24 hours at a charging cycle.*

### **How can I get maximum range or distance per charge?**

Rarely do you have an ideal driving situation such as smooth, flat, hard terrain with no wind, hills or curves. More often you are presented with hills, sidewalk cracks, uneven and loosely packed surfaces, curves, and wind. All of these factors affect the distance or running time per battery charge. The following are a few suggestions for obtaining the maximum range per charge.

- Always fully charge the batteries prior to your trip.

# IX. BATTERIES AND CHARGING

- Maintain **30–35 psi** in pneumatic drive wheels.
- Plan your trip in advance to avoid inclines if possible.
- Limit baggage weight to essential items.
- Try to maintain an even speed and avoid stop-and-go driving.

## What type of battery should I use?

We recommend deep-cycle batteries that are sealed and maintenance free. Both AGM and Gel-Cell are deep-cycle batteries that are similar in performance.

Use these specifications to reorder deep-cycle batteries:

Battery Specifications	
Type:	Deep-cycle AGM or Gel Cell
Size:	Group 24
Voltage:	12 volts each
Amperage:	70 - 80 amp hours
Size:	NF-22 (power seat option only)
Voltage:	12 volts each
Amperage:	45 - 55 amp hours



**WARNING! Corrosive chemicals contained in batteries. Use only AGM or Gel-Cell batteries to reduce the risk of leakage or explosive conditions.**

## Why do my new batteries seem weak?

Deep-cycle batteries employ a much different chemical technology than that used in car batteries, nickel-cadmium (nicads), or in other common battery types. Deep-cycle batteries are specifically designed to provide power, drain down their charge, and then accept a relatively quick recharge. Lead acid batteries should be charged as often as possible. They do not have a “memory” like nickel cadmium batteries.

We work closely with our battery manufacturer to provide a battery that best suits your Jazzy 1104’s specific demands. Fresh batteries arrive regularly at Pride and are promptly shipped with a full charge. During shipping, the batteries encounter temperature extremes that may influence initial performance. Heat robs the charge from the battery, and cold slows the power available and extends the time needed to recharge the battery (just as with a car battery).

It might take a few days for the temperature of the battery to stabilize and adjust to its new ambient temperature. More importantly, it takes a few “charging cycles” (a partial drain—then a full recharge) to establish the critical chemical balance that is essential to the battery’s peak performance and long life. It is well worth it to take the time to break in your battery properly.

## IX. BATTERIES AND CHARGING

*Note: The useful life of a battery is quite often a reflection of the care it receives.*

### **How can I ensure maximum battery life?**

A fully charged deep-cycle battery provides reliable performance and extended battery life. Keep your Jazzy's batteries fully charged whenever possible. Batteries that are regularly and deeply discharged, infrequently charged, or stored without a full charge may be permanently damaged, causing unreliable Jazzy operation and limited battery life.

### **How should I store my Jazzy 1104 and its batteries?**

If you do not use your Jazzy 1104 regularly, we recommend maintaining battery vitality by charging the batteries at least once a week.

If you do not plan on using your Jazzy 1104 for an extended period, fully charge the batteries prior to storage. Disconnect the battery harnesses and store the Jazzy in a warm, dry environment. Avoid temperature extremes, such as freezing and excessively hot conditions, and never attempt to charge a frozen battery. A cold or frozen battery should be warmed for several days prior to recharging.

*Note: If you are storing a Jazzy 1104 for an extended period of time, you may wish to block the unit up with several boards under the frame. This keeps the tires off the ground and prevents the possibility of flat spots developing.*

### **What about public transportation?**

If you intend to use public transportation while using your Jazzy, you must contact in advance the transportation provider to determine their specific requirements. See II. "Safety" for more details.

Sealed lead-acid and gel cell batteries are designed for application in power chairs and in other mobility vehicles. Generally, sealed lead-acid batteries are safe for all forms of transportation such as aircraft, buses, and trains. We suggest that you contact your transportation provider to determine specific requirements of transportation and packaging.

### **What about shipping?**

If you wish to use a freight company to ship your Jazzy 1104 to your final destination, repack your Jazzy 1104 in the original shipping container and ship the batteries in separate boxes.

# X. CARE AND MAINTENANCE

## ROUTINE MAINTENANCE

Your Jazzy is a sophisticated power chair. Like any motorized vehicle, it requires routine maintenance checks. You can perform some of these checks, but others require assistance from an authorized Pride provider. Preventive maintenance is very important. If you follow the maintenance checks in this section as scheduled, you can help ensure that your Jazzy gives you years of trouble-free operation. If you have any doubt as to your Jazzy's care or operation, contact your Pride provider.



**CAUTION! Your Jazzy 1104, like most electrical equipment, is susceptible to damage from the elements. Avoid damp areas of any kind. Direct exposure to water or dampness could cause the power chair to malfunction electronically and mechanically. Water can cause electrical components to corrode and the chair's frame to rust.**

### Should your Jazzy 1104 come in contact with water:

1. Dry your Jazzy 1104 as thoroughly as possible with a dry towel.
2. Allow your Jazzy 1104 to sit in a warm, dry place for 12 hours to allow unseen water to evaporate.
3. Check the joystick operation and the brakes before using your Jazzy again.
4. If any inconsistencies are found, take your Jazzy 1104 to an authorized service center.

## TEMPERATURE

Some of the parts of your Jazzy 1104 are susceptible to extreme changes in temperature. Always keep your Jazzy 1104 between the temperatures of 18° F and 122° F.

- In extremely cold temperatures the batteries may freeze. The specific temperature at which they freeze depends on a number of factors, such as battery charge, usage, and composition of the batteries (e.g., sealed lead-acid or gel cell).
- Temperatures above 122° F may cause your Jazzy 1104 to operate at a reduced speed. This reduced speed is a safety feature built into the controller that helps prevent damage to the motor and other electrical components. See VIII. "Operation" in this manual.

## GENERAL GUIDELINES

- Avoid knocking or bumping the controller, especially the joystick.
- Avoid prolonged exposure of your Jazzy to extreme conditions, such as heat, cold, or moisture.
- Keep the controller clean.
- Check all controller connectors on the utility tray to ensure that they are all tight and secured properly. Also check the charger harness connector.
- When the battery indicator gauge is completely lit, the batteries are fully charged, and the controller and the electrical system are OK.
- If one red bar on the battery indicator gauge is blinking slowly, the batteries are low and need to be charged, but the controller and the electrical system are OK.
- If the battery indicator gauge is blinking rapidly, the controller has detected a fault in either its own circuits or in your Jazzy's circuits. See VIII. "Operation" in this manual.
- Make sure the drive tires are inflated to **30 – 35 psi**. See figure 28.



**WARNING! Do not underinflate or overinflate your tires. Low pressure may result in loss of control, and overinflated tires may burst. Serious injury may result. Overinflating tires can cause them to explode and can result in personal injury.**

**WARNING! Do not use a high pressure hose to inflate your tires.**

# X. CARE AND MAINTENANCE

- Use a rubber conditioner on the tire sidewalls to help preserve them.



**WARNING! Never use a rubber conditioner on the tread area of the tires; doing so may make the tires slippery and cause your Jazzy to skid.**

- The body shroud has been sprayed with a clear sealant coating. You can apply a light coat of car wax to help it retain its high-gloss appearance.
- Check all electrical connections. Make sure they are tight and are not corroded. Batteries must sit flat within the battery well, with the battery terminals facing inward, toward each other. Refer to the frame decal for the correct wiring layout.
- All wheel bearings are prelubricated and sealed. They require no subsequent lubrication.



**Figure 38. Check Tire Pressure**

## DAILY CHECKS

- With the controller turned off, check the joystick. Make sure it is not bent or damaged and that it returns to the center when you release it. Check the rubber boot around the base of the joystick for damage. Visually inspect the boot. Do not handle or try to repair it. See your authorized service center if there is a problem.
- Visually inspect the controller harnesses. Make sure that they are not frayed or cut or have any wires exposed. See your authorized service provider if there is a problem with any of these harnesses.

## WEEKLY CHECKS

- Disconnect and inspect the controller and the charger harnesses from the utility tray. Look for corrosion. Contact your local Pride provider if necessary.
- Ensure that all parts of the controller system are securely fastened to your Jazzy. Do not overtighten any screws.
- Check for proper tire inflation. There should be 30 – 35 psi in each tire. If a tire does not hold air, see an authorized service provider for replacement of the tube.
- Calibrate the joystick if a noticeable difference in performance is detected or if the joystick does not operate properly.
- Check the brakes. This test should be carried out on a level surface with at least three feet of clearance around your Jazzy.

### To check the brakes:

1. Turn on the controller and turn down the speed response adjustment knob.
2. After one second, check the battery gauge. Make sure that it remains on.
3. Slowly push the joystick forward until you hear the electric brakes click. Immediately release the joystick. You must be able to hear each electrical brake operating by a “clicking” sound within a few seconds of joystick movement. Repeat this test three times, pushing the joystick backwards, then left, and then right.

# X. CARE AND MAINTENANCE

## MONTHLY CHECKS

- Check that the anti-tip wheels do not rub the ground when you operate the Jazzy. Adjust them as necessary. See VI. “Comfort Adjustments” in this manual.
- Check for extreme wear on the anti-tip wheels. Replace them as necessary.
- Check for drive tire wear. See an authorized Pride provider for repair.
- Check the rear casters for wear. Replace them as necessary.
- Check the rear forks for damage or fluttering which indicates that they may need to be adjusted or have the bearings replaced. See an authorized Pride provider for repair.
- Keep your Jazzy clean and free of foreign material, such as mud, dirt, hair, food, drink, etc.

## YEARLY CHECKS

Take your Jazzy to an authorized service provider for yearly maintenance. This helps ensure that your Jazzy is functioning properly and helps prevent future complications.

## STORAGE

Your power chair should be stored in a dry place, free from temperature extremes. When storing, disconnect the batteries from the Jazzy. See IX. “Batteries and Charging” in this manual.



**WARNING!** If you fail to store the unit properly, the frame can rust and the electronics can be damaged.

## CLEANING INSTRUCTIONS



**CAUTION!** Never hose off your Jazzy or place it in direct contact with water. Your Jazzy has a painted, ABS plastic body shroud that allows it to be easily wiped clean with a damp cloth.

**CAUTION!** Never use any chemicals to clean a vinyl seat, as they may cause the seat to become slippery or dry out and crack. Use soapy water and dry the seat thoroughly.

## TIRES AND TUBES

If your Jazzy 1104 is equipped with pneumatic tires, you should check the air pressure at least once a week. This prolongs the life of your tires and helps ensure the perfect operation of your chair. If you have a flat tire, replace the tube. Replacement tires and tubes are readily available at the provider shop where you purchased your Jazzy 1104.



**WARNING!** To avoid possible injury, be sure that the controller's power is turned off and the power chair is not in freewheel mode before performing this procedure.

**WARNING!** Make sure the tire is completely deflated before attempting repair.

**Follow these easy steps for a quick and safe repair:**

1. Completely deflate the tire if pneumatic.
2. Use a 3/4-in. wrench to remove the drive wheel bolt from the center hub of the wheel. See figure 29.
3. Pull the wheel off of the axle.
4. Remove the nuts that hold the wheel rims together.

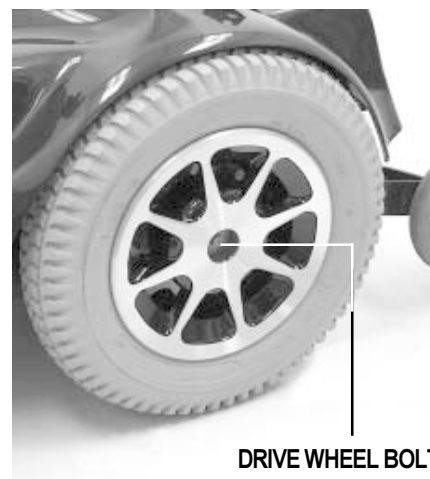

Figure 29. Drive Wheel

# X. CARE AND MAINTENANCE

5. Remove the old tube and/or tire and replace it with a new tube and/or tire.
6. Reassemble the wheel.
7. Slide the wheel back onto the shaft.
8. Install the drive wheel bolt into the center hub and tighten.
9. Inflate the tire to **30 – 35 psi**.

## BATTERY REPLACEMENT

A diagram is printed on a decal on the Jazzy 1104 frame near the battery tray.



**WARNING! Battery posts, terminals, and related accessories contain lead and lead compounds. Wear goggles and gloves when handling batteries and wash hands after handling.**

### To replace the batteries:

1. Turn the power off.
2. Unplug the controller wire harness.
3. Remove the seat.
4. Remove the body shroud.
5. Loosen the wing nuts on the positive (red) battery terminals first.
6. Remove the wires.
7. Loosen the wing nuts on the negative (black) battery terminals.
8. Remove the wires.
9. Replace the batteries.
10. Install the batteries into your Jazzy 1104 with the terminal sides of the batteries facing inward, toward each other.
11. Connect the wire marked (+) to the closest positive (red) battery terminal.
12. Connect the wire marked (-) to the closest negative (black) battery terminal on the other battery.
13. Connect one circuit breaker harness to the empty positive terminal of one battery, and connect the other circuit breaker harness to the empty negative terminal of the other battery.



**WARNING! Make sure you tighten the fasteners so that the connections are secure.**

# X. CARE AND MAINTENANCE

## MOTOR BRUSHES

The electric motors that power your Jazzy 1104 use carbon brushes. These brushes may become susceptible to wear over a long period of time. The motor brushes are the two contacts located inside the motor assembly that supply power to the motor. They are designed to provide several thousand hours of operation. However, if the brushes become dirty with carbon deposits or wear out, the motor will run poorly or not at all.



**CAUTION!** If inspection determines excessive wear on the brushes, they must be replaced or motor damage will result. Failure to maintain the brushes could void the warranty.

### To inspect or replace the motor brushes:

1. Remove the seat, body shroud, and batteries. See VII. “Disassembly” in this manual.
2. Unscrew the motor brush caps. See figure 30.
3. Remove the brushes.
4. Inspect for wear.
5. Replace brushes, if necessary. Contact your local authorized Pride provider for replacement brushes.

## WHEN TO SEE YOUR PRIDE PROVIDER FOR SERVICE

The following symptoms could indicate a serious problem with your Jazzy 1104. If necessary, contact an authorized Pride provider. When calling, have the model number, serial number, nature of the problem, and the trouble code if available.

- Motor noise
- Frayed harnesses
- Cracked or broken connectors
- Uneven wear on any of the tires
- Jerky motion
- Pulling to one side
- Bent or broken wheel assemblies
- Does not power up
- Powers up, but does not move

MOTOR  
BRUSH CAP



Figure 30. Motor

## CORRECTIVE MAINTENANCE

If the battery indicator gauge does not light up when you turn on the power:

- Check the harness connections. Make sure they are tight.
- Check the circuit breaker. Reset it if necessary.
- Check the battery connections.

If the above conditions prove normal, you can load test the batteries with a battery load tester. These testers are available at automotive parts stores. Disconnect both batteries before load testing and follow the directions that come with the load tester. If either one of the batteries fails the load test, replace both of them. If your Jazzy 1104 still does not power up, contact your local Pride provider.



# XI. OPTIONAL ACCESSORIES

The following accessories are available from your local Pride provider.

## POSITIONING BELT



**WARNING! The positioning belt is not designed for use as a seat belt in a motor vehicle. Nor is your Jazzy 1104 suitable for use as a seat in any vehicle. Anyone traveling in a vehicle should be properly belted into seats approved by the auto manufacturer.**

The positioning belt is designed to support the operator so that he or she does not slide down or forward in the seat. The positioning belt is not designed for use as a restraining device. Make sure the belt is secure but does not cause discomfort.

## OXYGEN TANK HOLDER

The removable oxygen tank holder is mounted to the back of the seat by means of the accessory bracket.

## CANE AND CRUTCH HOLDER

The removable cane and crutch holder is mounted to the back of the seat by means of the accessory bracket.

## WALKER HOLDER

The removable walker holder is mounted to the back of the seat by means of the accessory bracket. It can hold a standard size walker.

## REAR BASKET

The rear basket is mounted to the accessory bracket. It has a handle that can be used when removing the basket from your Jazzy 1104.

## CUP HOLDER (NOT SHOWN)

The cup holder is mounted to the armrest.

## ANTI-SCUFF DECAL

Your Jazzy comes with contoured anti-scuff decals. See figure 31. These decals help protect the rear corners of your Jazzy's body shroud. They are made from translucent, textured polyurethane plastic that provides a tough, attractive finish. Each piece has an adhesive back for easy application.



Figure 31. Anti-Scuff Decal

### To apply your anti-scuff decals:

1. Peel the backing away from the anti-scuff decal.
2. Apply the decal along the contour of the shroud.

# XII. WARRANTY

## LIFETIME LIMITED WARRANTY

For the lifetime of your Blast from the date of purchase, Pride will repair or replace at our option, to the original purchaser, free of charge, any of the following parts found upon examination by an authorized representative of Pride to be defective in material and/or workmanship:

- Structural frame components

## Two-Year Warranty

For two (2) years from the date of purchase, Pride will repair or replace at our option, to the original purchaser, free of charge, any of the following parts found upon examination by an authorized representative of Pride to be defective in material and/or workmanship:

- Electronics

## Eighteen-Month Warranty

For eighteen (18) months from the date of purchase, Pride will repair or replace, at our option to the original purchaser, free of charge, any of the following parts found upon examination by an authorized representative of Pride to be defective in material and/or workmanship:

- Motor/gearbox assembly

## Warranty Exceptions

Motor: If damage occurs to the commutator of a motor as a result of not replacing the motor brushes after heavy wear to the brushes. Motor brushes are wear items and are not warranted.

Brake: One (1) year warranty for the electrical function of the brake. Brake pads are a wear item and are not warranted.

## Six-Month Limited Warranty

For six (6) months from date of purchase, Pride will repair or replace, at our option, to the original purchaser, free of charge, any of the following parts found upon examination by an authorized representative of Pride to be defective in material and/or workmanship:

- Plastic components, except body
- Rubber components (except tires and tubes)
- Bearings and bushings
- Casters and anti-tip wheels

Battery warranty is covered by the battery manufacturer. Battery warranty is not covered by Pride.

Warranty service can be performed by an authorized Pride provider or by Pride. Do not return faulty parts to Pride without prior consent. All transportation costs and shipping damage incurred while submitting parts for repair or replacement are the responsibility of the original purchaser.

## Warranty Exclusions

- ABS plastic body shrouds and footrest covers (wear items)
- Batteries (battery manufacturer provides a six-month limited warranty)
- Tires and tubes
- Upholstery and seating
- Repairs and/or modifications made to any part without specific consent from Pride
- Circumstances beyond the control of Pride
- Labor, service calls, shipping, and other charges incurred for repair of the product, unless specifically authorized by Pride Mobility Products Corporation

Damage caused by:

- Battery fluid spillage or leakage
- Abuse, misuse, accident, or negligence
- Improper operation, maintenance, or storage
- Commercial use or use other than normal

There is no other express warranty.

Implied warranties, including those of merchantability and fitness for a particular purpose, are limited to one (1) year from the date of purchase and to the extent permitted by law. Any and all implied warranties are excluded. This is the exclusive remedy. Liabilities for consequential damages under any and all warranties are excluded.

Some states do not allow limitations on how long an implied warranty lasts or do not allow the exclusion of limitation of incidental or consequential damages, so the above limitation or exclusion may not apply to you.

This warranty gives you specific rights, and you may also have other rights which vary from state to state.

Please fill out and return the warranty card to Pride. This assists Pride in providing the best possible technical and customer service.

# Jazzy Power Chairs®

*How a Power Chair Should Feel™*



## Quality Control- Model 1104

Thank you for making the Pride Jazzy your choice in Power Chairs.

We have thoroughly inspected your Jazzy. The following checkmarks indicate that it has been test driven and inspected.

**Model #** \_\_\_\_\_

**Serial #** \_\_\_\_\_



Pride keeps a more detailed report on file at the factory.

\_\_\_\_\_  
Date Inspected

\_\_\_\_\_  
Inspector