

# Owner's Operator And Maintenance Manual

# P7E

DEALER: THIS MANUAL MUST BE GIVEN TO THE USER OF THE WHEELCHAIR.

USER: BEFORE USING THIS WHEELCHAIR, READ THIS MANUAL AND SAVE FOR FUTURE REFERENCE.



W  
A  
R  
N  
I  
N  
G

## WARNING

DO NOT OPERATE THIS EQUIPMENT WITHOUT FIRST READING AND UNDERSTANDING THIS MANUAL. IF YOU ARE UNABLE TO UNDERSTAND THE WARNINGS, CAUTIONS, AND INSTRUCTIONS, CONTACT A HEALTHCARE PROFESSIONAL, DEALER OR TECHNICAL PERSONNEL IF APPLICABLE BEFORE ATTEMPTING TO USE THIS EQUIPMENT - OTHERWISE INJURY OR DAMAGE MAY RESULT. THE INITIAL SET UP OF THIS WHEELCHAIR MUST BE PERFORMED BY A QUALIFIED TECHNICIAN. PROCEDURES OTHER THAN THOSE DESCRIBED IN THIS MANUAL MUST BE PERFORMED BY A QUALIFIED TECHNICIAN.

## SPECIAL NOTES

WARNING/CAUTION notices as used in this manual apply to hazards or unsafe practices which could result in personal injury or property damage.

### NOTICE

THE INFORMATION CONTAINED IN THIS DOCUMENT IS SUBJECT TO CHANGE WITHOUT NOTICE.

### WHEELCHAIR USER

As a manufacturer of wheelchairs, Invacare endeavors to supply a wide variety of wheelchairs to meet many needs of the user. However, final selection of the type of wheelchair to be used by an individual rests solely with the user and his/her healthcare professional capable of making such a selection.

### WHEELCHAIR TIE-DOWN RESTRAINTS AND SEAT POSITIONING STRAPS

Invacare recommends that wheelchair users NOT be transported in vehicles of any kind while in wheelchairs. As of this date, the Department of Transportation has not approved any tie-down systems for transportation of a user while in a wheelchair, in a moving vehicle of any type.

It is Invacare's position that users of wheelchairs should be transferred into appropriate seating in vehicles for transportation and use be made of the restraints made available by the auto industry. Invacare cannot and does not recommend any wheelchair transportation systems.

AS REGARDS RESTRAINTS - SEAT POSITIONING STRAPS - IT IS THE OBLIGATION OF THE DME DEALER, THERAPISTS AND OTHER HEALTHCARE PROFESSIONALS TO DETERMINE IF A SEAT POSITIONING STRAP IS REQUIRED TO ENSURE THE SAFE OPERATION OF THIS EQUIPMENT BY THE USER. SERIOUS INJURY CAN OCCUR IN THE EVENT OF A FALL FROM A WHEELCHAIR.

**SAVE THESE INSTRUCTIONS**

# TABLE OF CONTENTS

<b>SPECIAL NOTES</b> .....	<b>2</b>	<b>PROCEDURE 5 - SEAT FRAME</b> .....	<b>27</b>
<b>SAFETY SUMMARY</b> .....	<b>5</b>	ADJUSTING SEAT WIDTH .....	27
<b>SAFETY/HANDLING OF WHEELCHAIRS</b> .	<b>8</b>	ADJUSTING SEAT DEPTH .....	28
<b>FEATURES</b> .....	<b>11</b>	<b>PROCEDURE 6 - BATTERIES</b> .....	<b>29</b>
<b>SPECIFICATIONS</b> .....	<b>12</b>	INSTALLING/REMOVING BATTERY TRAY .....	29
<b>PACKAGING/HANDLING</b> .....	<b>13</b>	REPLACING THE BATTERIES .....	30
<b>SAFETY INSPECTION CHECKLIST</b> .....	<b>14</b>	BATTERY INSTALLATION .....	30
<b>TROUBLESHOOTING</b> .....	<b>15</b>	INSTALLING/REMOVING BATTERY BOX(ES) .....	32
TROUBLESHOOTING GUIDE MECHANICAL .....	15	WHEN TO CHARGE BATTERIES .....	32
TROUBLESHOOTING GUIDE ELECTRICAL .....	15	CHARGING THE BATTERIES .....	32
CHECKING BATTERY CHARGE LEVEL .....	16	<b>PROCEDURE 7 - ELECTRONICS</b> .....	<b>34</b>
USING HYDROMETER TO CHECK		PREPARING THE MKIV-RII Joystick for Use .....	34
BATTERY CELLS (DIGITAL VOLTMETER		Disconnecting/Connecting the MKIV-RII-lp Controller	
NOT AVAILABLE) (LEAD ACID) .....	17	Motor and Battery Leads .....	34
MOTOR TESTING .....	18	Repositioning the MKIV-RII Joystick .....	35
MOTOR BRUSH INSPECTION .....	18	REMOVING/INSTALLING	
ELECTROMECHANICAL PARKING		THE MKIV-RII-LP CONTROLLER .....	35
BRAKE TESTING .....	19	<b>PROCEDURE 8 - RETAINING STRAP</b> ...	<b>36</b>
<b>PROCEDURE 1 - ASSEMBLY</b> .....	<b>20</b>	REPLACING BATTERY BOX RETAINING	
ASSEMBLING THE P7E .....	20	STRAP .....	36
<b>PROCEDURE 2 - FRONT RIGGINGS</b> .....	<b>21</b>	<b>PROCEDURE 9 - WIRING HARNESS</b> .....	<b>37</b>
SWINGAWAY FOOTREST ASSEMBLY		REPLACING THE WIRING HARNESS ...	37
INSTALLATION .....	21	<b>PROCEDURE 10 - WHEELS/ANTI-TIPPER</b> .	<b>38</b>
SWINGAWAY FOOTREST HEIGHT		ENGAGING/DISENGAGING CLUTCHES .....	38
ADJUSTMENT .....	21	USING/INSTALLING/ADJUSTING WHEEL	
HEEL LOOP REPLACEMENT .....	22	LOCKS .....	39
ELEVATING LEGREST ASSEMBLY		REPLACING PNEUMATIC TIRES AND TUBES -	
INSTALLATION .....	22	FRONT CASTERS AND REAR WHEELS .....	40
ADJUSTING THE ELEVATING LEGREST		INSTALLING/REPLACING REAR WHEEL	
ASSEMBLY .....	23	ASSEMBLIES .....	40
<b>PROCEDURE 3 - ARMS</b> .....	<b>24</b>	INSTALLING/REPLACING FRONT CASTER	
ADJUSTING ARMREST HEIGHT, REMOVING		ASSEMBLIES .....	41
OR REPLACING ARMRESTS .....	24	REPLACING FRONT FORK .....	41
REPLACING/REPOSITIONING DESK/FULL		INSTALLING/REMOVING THE ANTI-TIPPERS ....	41
LENGTH ARMREST PAD/PLASTIC SNAP .....	24	INSTALLING OPTIONAL CLUTCH	
REPLACING CLOTHING GUARDS		EXTENSION HANDLES .....	42
(FIXED HEIGHT ARMS ONLY) .....	25	<b>PROCEDURE 11 - MOTOR/GEARBOX</b> ...	<b>43</b>
<b>PROCEDURE 4 - UPHOLSTERY/</b>		REPLACING THE MOTOR GEARBOX .....	43
<b>RESTRAINT</b> .....	<b>26</b>	<b>LIMITED WARRANTY</b> .....	<b>Back (44)</b>
REPLACING THE SEAT UPHOLSTERY .....	26		
REPLACING THE BACK UPHOLSTERY .....	26		
REPLACING THE SEAT RESTRAINT .....	26		

# **SAFETY SUMMARY**

**S  
A  
F  
E  
T  
Y  
  
S  
U  
M  
M  
A  
R  
Y**

## **REPAIR OR SERVICE INFORMATION**

If the wheelchair does NOT perform to specifications, turn the wheelchair OFF immediately and contact authorized dealer.

## **OPERATING INFORMATION**

### **WARNING**

To determine and establish your particular safety limits, practice bending, reaching and transferring activities in several combinations in the presence of a qualified health professional BEFORE attempting active use of the wheelchair.

DO NOT attempt to reach objects if you have to move forward in the seat.

DO NOT attempt to reach objects if you have to pick them up from the floor by reaching down between your knees.

DO NOT lean over the top of the back upholstery to reach objects from behind as this may cause the wheelchair to tip over.

DO NOT shift your weight or sitting position toward the direction you are reaching as the wheelchair may tip over.

DO NOT tilt the wheelchair without assistance.

DO NOT use an escalator to move a wheelchair between floors. Serious bodily injury may occur.

Before attempting to transfer in or out of the wheelchair, every precaution should be taken to reduce the gap distance. Turn both casters toward the object you are transferring onto. Also be certain the power is OFF and wheel locks are engaged to prevent the wheels from moving.

Wheel locks are an OPTION on this wheelchair, (you may order with or without wheel locks). Invacare strongly recommends ordering the wheel locks as an additional safeguard for the Action wheelchair user. Transfer to and from the wheelchair in the presence of a qualified healthcare professional to determine individual safety limits.

DO NOT engage or disengage the clutches until the power is in the OFF position.

DO NOT operate on roads, streets or highways.

DO NOT climb, go up or down ramps or traverse slopes greater than 9°.

DO NOT attempt to move up or down an incline with a water, ice or oil film.

DO NOT attempt to drive over curbs or obstacles. Doing so may cause your wheelchair to turn over and cause bodily harm or damage to the wheelchair.

DO NOT use unauthorized parts, accessories, or adapters other than those authorized by Invacare.

DO NOT leave the power ON when entering or exiting your wheelchair.

DO NOT attempt to lift the wheelchair by any removable (detachable) parts. Lifting by means of any removable (detachable) parts of a wheelchair may result in injury to the user or damage to the wheelchair.

DO NOT stand on the frame of the wheelchair.

Anti-tippers MUST BE attached at all times.

DO NOT use the footplates as a platform. When getting in or out of the wheelchair, make sure that the footplates are in the upward position or swing footrests towards the outside of the wheelchair.

ALWAYS wear your seat restraint.

**SAFETY SUMMARY (CONTINUED)****TIRE PRESSURE**

DO NOT use your power wheelchair unless it has the proper tire pressure (p.s.i.). DO NOT overinflate the tires. Failure to follow these suggestions may cause the tire to explode and cause bodily harm.

**ELECTRICAL****Grounding Instructions:**

DO NOT, under any circumstances, cut or remove the round grounding prong from any plug used with or for Invacare products. Some devices are equipped with three-prong (grounding) plugs for protection against possible shock hazards. Where a two-prong wall receptacle is encountered, it is the personal responsibility and obligation of the customer to contact a qualified electrician and have the two-prong receptacle replaced with a properly grounded three-prong wall receptacle in accordance with the National Electrical Code. If you must use an extension cord, use ONLY a three-wire extension cord having the same or higher electrical rating as the device being connected. In addition, Invacare has placed RED/ORANGE WARNING TAGS on some equipment. DO NOT remove these tags. Carefully read battery/battery charger information prior to installing, servicing or operating your wheelchair.

**RAIN TEST**

INVACARE has tested its Action power wheelchairs in accordance with ISO 7176 Part 9 "Rain Test". This provides the end user or his/her assistant sufficient time to remove his/her power wheelchair from a rain storm and retain wheelchair operation.

DO NOT leave your power wheelchair in a rain storm of any kind.

DO NOT use your power wheelchair in a shower or leave it in a damp bathroom while taking a shower.

DO NOT leave your power wheelchair in a damp area for any length of time.

Direct exposure to rain or dampness will cause the wheelchair to malfunction electrically and mechanically; may cause the wheelchair to prematurely rust.

Check to ensure that the battery covers are secured in place, joystick boot is NOT torn or cracked where water can enter and that all electrical connections are secure at all times.

DO NOT use the joystick if the boot is torn or cracked. If the joystick boot becomes torn or cracked, replace IMMEDIATELY.

**WEIGHT TRAINING**

Invacare DOES NOT recommend the use of its Action wheelchairs as a weight training apparatus. Action wheelchairs have NOT been designed or tested as a seat for any kind of weight training. If occupant uses said wheelchair as a weight training apparatus, Invacare shall NOT be liable for bodily injury and the warranty will be voided immediately.

**WEIGHT LIMITATION**

The P7E has a weight limitation of 200 lbs.

## SAFETY SUMMARY (CONTINUED)

### CAUTION:

IT IS VERY IMPORTANT THAT YOU READ THIS INFORMATION REGARDING THE POSSIBLE EFFECTS OF ELECTROMAGNETIC INTERFERENCE ON YOUR POWERED WHEELCHAIR.

### WARNING

#### Electromagnetic Interference (EMI) From Radio Wave sources

Powered wheelchairs and motorized scooters (in this text, both will be referred to as powered wheelchairs) may be susceptible to electromagnetic interference (EMI), which is interfering electromagnetic energy (EM) emitted from sources such as radio stations, TV stations, amateur radio (HAM) transmitters, two way radios, and cellular phones. The interference (from radio wave sources) can cause the powered wheelchair to release its brakes, move by itself, or move in unintended directions. It can also permanently damage the powered wheelchair's control system. The intensity of the interfering EM energy can be measured in volts per meter (V/m). Each powered wheelchair can resist EMI up to a certain intensity. This is called its "immunity level." The higher the immunity level, the greater the protection. At this time, current technology is capable of achieving at least a 20 V/m immunity level, which would provide useful protection from the more common sources of radiated EMI. This powered wheelchair model as shipped, with the MKIV-R11-LP controller has an unknown immunity level.

There are a number of sources of relatively intense electromagnetic fields in the everyday environment. Some of these sources are obvious and easy to avoid. Others are not apparent and exposure is unavoidable. However, we believe that by following the warnings listed, your risk to EMI will be minimized.

The sources of radiated EMI can be broadly classified into three types:

1) Hand-held Portable transceivers (transmitters-receivers with the antenna mounted directly on the transmitting unit. Examples include: citizens band (CB) radios, "walkie talkie," security, fire, And police transceivers, cellular telephones, and other personal communication devices.

*\*\*NOTE: Some cellular telephones and similar devices transmit signals while they are ON, even when not being used;*

2) Medium-range mobile transceivers, such as those used in police cars, fire trucks, ambulances, and taxis. These usually have the antenna mounted on the outside of the vehicle; and

3) Long-range transmitters and transceivers, such as commercial broadcast transmitters (radio and TV broadcast antenna towers) and amateur (HAM) radios.

*NOTE: Other types of hand-held devices, such as cordless phones, laptop computers, AM/FM radios, TV sets, CD players, cassette players, and small appliances, such as electric shavers and hair dryers, so far as we know, are not likely to cause EMI problems to your powered wheelchair.*

#### Powered Wheelchair Electromagnetic Interference (EMI)

Because EM energy rapidly becomes more intense as one moves closer to the transmitting antenna (source), the EM fields from hand-held radio wave sources (transceivers) are of special concern. It is possible to unintentionally bring high levels of EM energy very close to the powered wheelchair's control system while using these devices. This can affect powered wheelchair movement and braking. Therefore, the warnings listed are recommended to prevent possible interference with the control system of the powered wheelchair.

**SAFETY SUMMARY (CONTINUED)****WARNINGS**

Electromagnetic interference (EMI) from sources such as radio and TV stations, amateur radio (HAM) transmitters, two-way radios, and cellular phones can affect powered wheelchairs and motorized scooters. Following the warnings listed below should reduce the chance of unintended brake release or powered wheelchair movement which could result in serious injury.

- 1) Do not operate hand-held transceivers (transmitters receivers), such as citizens band (CB) radios, or turn ON personal communication devices, such as cellular phones, while the powered wheelchair is turned ON;
- 2) Be aware of nearby transmitters, such as radio or TV stations, and try to avoid coming close to them;
- 3) If unintended movement or brake release occurs, turn the powered wheelchair OFF as soon as it is safe;
- 4) Be aware that adding accessories or components, or modifying the powered wheelchair, may make it more susceptible to EMI (Note: There is no easy way to evaluate their effect on the overall immunity of the powered wheelchair); and
- 5) Report all incidents of unintended movement or brake release to the powered wheelchair manufacturer, and note whether there is a source of EMI nearby.

**IMPORTANT INFORMATION**

- 1) 20 volts per meter (V/m) is a generally achievable and useful immunity level against EMI (as of May 1994) (the higher the level, the greater the protection);
- 2) The MKIV-RII-LP controller has an unknown immunity level.

P7E Frame with MKIV-RII Joystick.

Modification of any kind to the electronics of this wheelchair as manufactured by Invacare may adversely affect the RFI immunity levels.

## SAFETY/HANDLING OF WHEELCHAIRS

“SAFETY AND HANDLING” of the wheelchair requires the close attention of the wheelchair user as well as the assistant. This manual points out the most common procedures and techniques involved in the safe operation and maintenance of the wheelchair. It is important to practice and master these safe techniques until you are comfortable in maneuvering around the frequently encountered architectural barriers.

Use this information only as a “basic” guide. The techniques that are discussed on the following pages have been used successfully by many.

Individual wheelchair users often develop skills to deal with daily living activities that may differ from those described in this manual. Invacare recognizes and encourages each individual to try what works best for him/her in overcoming architectural obstacles that they may encounter. Techniques in this manual are a starting point for new wheelchair users and assistants with “safety” as the most important consideration for all.

### STABILITY AND BALANCE

#### WARNING

**ALWAYS WEAR YOUR SEAT RESTRAINT.**

To assure stability and proper operation of your wheelchair, you must at all times maintain proper balance. Your wheelchair has been designed to remain upright and stable during normal daily activities as long as you do not move beyond the center of gravity.

**DO NOT lean forward out of the wheelchair any further than the length of the armrests. Make sure the casters are pointing in the forward position whenever you lean forward. This can be achieved by advancing the wheelchair and then reversing it in a straight line.**

### COPING WITH EVERYDAY OBSTACLES

Coping with the irritation of everyday obstacles can be alleviated somewhat by learning how to manage your wheelchair. Keep in mind your center of gravity to maintain stability and balance.

### A NOTE TO WHEELCHAIR ASSISTANTS

When assistance to the wheelchair user is required, remember to use good body mechanics. Keep your back straight and bend your knees whenever tilting the wheelchair or traversing curbs, or other impediments.

Also, be aware of detachable parts such as arms or legrests. These must NEVER be used for hand-hold or lifting supports, as they may be inadvertently released, resulting in possible injury to the user and/or assistant(s).

When learning a new assistance technique, have an experienced assistant help you before attempting it alone.

### TILTING

#### WARNING

**DO NOT tilt the wheelchair without assistance.**

When tilting the wheelchair, an assistant should grasp the back of the wheelchair on a non-removable (non-detachable) part. Inform the wheelchair occupant before tilting the wheelchair and remind him/her to lean back. Be sure the occupant’s feet and hands are clear of all wheels.

### TILTING - CURBS:

After mastering the techniques of tilting the wheelchair, use this procedure to tackle curbs, short stairs, etc.

Unless the first assistant has exceptional upper body strength, it is recommended that this procedure be performed with two (2) assistants. The second assistant should be positioned at the front of the wheelchair lifting upward on a non-removable (non-detachable) part of the wheelchair frame when lifting the wheelchair and stabilizing the wheelchair when the wheelchair is being lowered to the ground.

The first assistant should turn the anti-tippers so the wheels are pointing up, apply a continuous downward motion until the balance point is achieved and the front casters clear the curb. At this point, the assistants will feel a difference in the weight distribution.

Roll the wheelchair forward and Slowly lower the wheelchair in one continuous movement. Do not let the wheelchair drop the last few inches to the ground. This could result in injury to the occupant. Push the wheelchair forward until the rear wheels roll up and over the curb.

#### WARNING

**Make sure anti-tipper wheels are pointing down towards the ground/floor BEFORE using the wheelchair.**

*Turn the anti-tipper wheels down towards the ground/floor.*

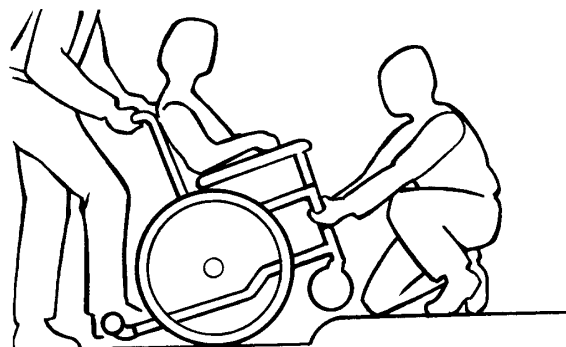

TILTING: CURBS



## STAIRWAY

**WARNING**

DO NOT attempt to move an occupied power wheelchair between floors using a stairway. Use an elevator to move an occupied power wheelchair between floors. If moving a power wheelchair between floors by means of a stairway, the occupant **MUST** be removed and transported independently of the power wheelchair.

Extreme caution is advised when it is necessary to move an UNOCCUPIED power wheelchair up or down the stairs. Invacare recommends using two (2) assistants and making thorough preparations. Make sure to use **ONLY** secure, non-detachable parts for hand-hold supports.

DO NOT attempt to lift the wheelchair by any removable (detachable) parts. Lifting by means of any removable (detachable) parts of a wheelchair may result in injury to the user or damage to the wheelchair.

Follow this procedure for moving wheelchair between floors when an elevator is NOT available:

**CAUTION**

The weight of the wheelchair without the user and batteries is still over 78 lbs. Use proper lifting techniques (lift with legs) to avoid injury.

1. Remove the occupant from the wheelchair.
2. Remove the battery box(es) from the rear of the wheelchair. Refer to INSTALLING/REMOVING BATTERY BOX(ES) in PROCEDURE 6 of this manual.
3. Remove the anti-tippers from the wheelchair. Refer to INSTALLING/REMOVING THE ANTI-TIPPERS in PROCEDURE 10 of this manual.
4. Disengage the clutches. Refer to ENGAGING/DISENGAGING CLUTCHES in PROCEDURE 10 of this manual.
5. After the wheelchair has been tilted back to the balance point, one assistant (in the rear) backs the wheelchair up against the first step, while securely grasping a non-removable (non-detachable) part of the wheelchair for leverage.



6. The second assistant, with a firm hold on a non-detachable part of the framework, lifts the wheelchair up and over the stair and steadies the wheelchair as the first assistant places one (1) foot on the next stair and repeats STEP 1.
7. The wheelchair should not be lowered until the last stair has been negotiated and the wheelchair has been rolled away from the stairway.

**WARNING**

Make sure anti-tipper wheels are pointing down towards the ground/floor **BEFORE** using wheelchair.

3. Reinstall the anti-tippers to the wheelchair. Refer to INSTALLING/REMOVING THE ANTI-TIPPERS in PROCEDURE 10 of this manual.
9. Engage the clutches. Refer to ENGAGING/DISENGAGING CLUTCHES in PROCEDURE 10 of this manual.

**ESCALATORS? SORRY!**

DO NOT use an escalator to move a wheelchair between floors. Serious bodily injury may occur.

**TRANSFERRING TO/FROM OTHER SEATS****WARNING**

**BEFORE** attempting to transfer in or out of the wheelchair, every precaution should be taken to reduce the gap distance. Turn both casters toward the object you are transferring onto. Also be certain the wheel locks\* are engaged to help prevent the wheels from moving.

\*Wheel locks are an **OPTION** on this wheelchair, (you may order with or without wheel locks). Transfer to and from the wheelchair in the presence of a qualified healthcare professional to determine individual safety limits. Invacare strongly recommends ordering the wheel locks as an additional safeguard for the Action wheelchair user.

**CAUTION**

When transferring, position yourself as far back as possible in the seat. This will prevent broken screws, damaged upholstery and the possibility of the wheelchair tipping forward.

*NOTE: This activity may be performed independently provided you have adequate mobility and upper body strength.*



## SAFETY/HANDLING

Position the wheelchair as close as possible along side the seat to which you are transferring, with the front casters pointing toward it. Engage wheel locks\*. Shift body weight into seat with transfer.

During independent transfer, little or no seat platform will be beneath you. Use a transfer board if at all possible.

### PERCENTAGE OF WEIGHT DISTRIBUTION

#### WARNING

**DO NOT** attempt to reach objects if you have to move forward in the seat or pick them up from the floor by reaching down between your knees.

Many activities require the wheelchair owner to reach, bend and transfer in and out of the wheelchair. These movements will cause a change to normal balance, center of gravity, and weight distribution of the wheelchair. To determine and establish your particular safety limits, practice bending, reaching and transferring activities in several combinations in the presence of a qualified health professional BEFORE attempting active use of the wheelchair.

Proper positioning is essential for your safety. When reaching, leaning, bending or bending forward, it is important to use the front casters as a tool to maintain stability and balance.

### FUNCTIONAL REACH FROM A WHEELCHAIR

The approximate reach-limit values shown in the accompanying graphs were derived on the basis of a sample of 91 male and 36 female subject wheelchair users. Note the difference between the maximum and the comfortable reach limits, a subjective but important consideration in design.

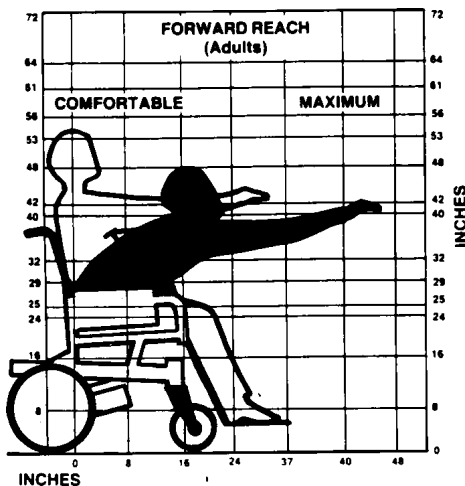

### REACHING, LEANING, BENDING AND BENDING - FORWARD

Position the front casters so that they are extended as far forward as possible and engage wheel locks\*. **DO NOT LEAN FORWARD OF THE ARMRESTS.**



#### WARNING

\*Wheel locks are an **OPTION** on this wheelchair, (you may order with or without wheel locks). Transfer to and from the wheelchair in the presence of a qualified healthcare professional to determine individual safety limits. Invacare strongly recommends ordering the wheel locks as an additional safeguard for the Action wheelchair user.

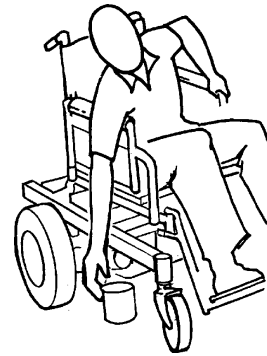

### REACHING, BENDING - BACKWARDS

#### WARNING

**DO NOT** lean over the top of the back upholstery. This will change your center of gravity and may cause you to tip over.



Position wheelchair as close as possible to the desired object. Point front casters forward to create the longest possible wheelbase. Reach back only as far as your arm will extend without changing your sitting position.

# FEATURES

FEATURES

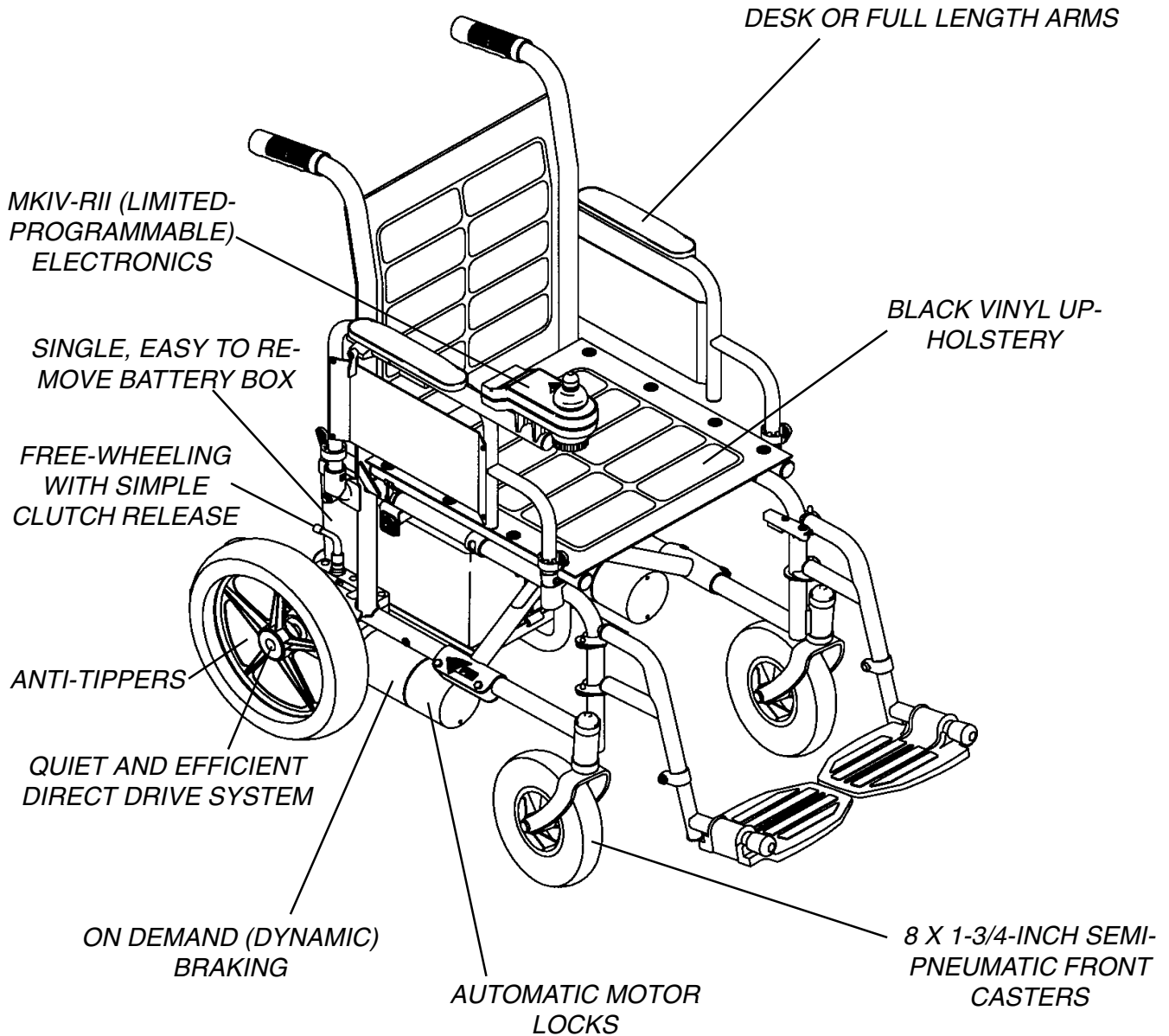

## FEATURES NOT SHOWN

4 AMP SINGLE MODE (GEL CELL) AUTOMATIC BATTERY CHARGER  
TRANSPORTABLE

AUTO-STYLE BUCKLE SEAT RESTRAINT

REVERSE POLARITY PROTECTION - TO PREVENT ELECTRICAL DAMAGE IN THE EVENT OF INCORRECT BATTERY HOOKUP

CHARGER LOCKOUT - PREVENTS THE WHEELCHAIR FROM BEING DRIVEN WHILE CONNECTED TO A BATTERY CHARGER

**SPECIFICATIONS**

**SPECIFICATIONS**

*NOTE: All specifications are approximate.*

**S  
P  
E  
C  
I  
F  
I  
C  
A  
T  
I  
O  
N  
S**

	<b>P7E</b>
<b>Seat Width Range:</b>	16 to 18-inches - In 2-inch increments
<b>Seat Depth Range:</b>	16 to 18-inches - In 1-inch increments with seat extension kits
<b>Back Height:</b>	16-1/2-inches
<b>Seat-to-Floor (approximate):</b>	20-1/2-inches
<b>Overall Width (Limited-Programmable w/MKIV-RII Controller)</b>	
<b>Open:</b>	24 to 26-inches
<b>Closed:</b>	14-1/2-inches
<b>Overall Height:</b>	37-inches
<b>*Overall Length (with front riggings and anti-tippers):</b>	41-3/4 to 43-3/4-inches
<b>** Weight</b>	
<b>W/O Batteries:</b>	77 lbs.
<b>W/ Batteries:</b>	126 lbs.
<b>Shipping (approximate):</b>	105-110 lbs.
<b>Rear Wheels/Tires: (Foam Filled or Pneumatic)</b>	12-1/2 x 2-1/4 inches
<b>Casters w/Precision Sealed Bearings:</b>	8 x 1-3/4-inches Semi Pneumatic (Standard) 8 x 2-inches Pneumatic (Optional)
<b>Anti-Tippers:</b>	Rotating, Removable (Standard)
<b>Footrest:</b>	Swingaway, Removable
<b>Armrests:</b>	Fixed Height - Desk and Full Length (Standard) Adjustable Height - Desk and Full Length (Optional)
<b>Frame/Front Riggings Colors:</b>	Wet Black
<b>Upholstery:</b>	Black Vinyl
<b>Battery/Size (Not Supplied): Two (2) Required</b>	U1 - Deep Cycle (Gel Cell)

*\* NOTE: Range is with P93 riggings.*

*\*\* NOTE: 18 x 16 -inch wheelchair with MKIV-RII (Limited-Programmable) electronics.*

**PERFORMANCE**

	<b>P7E</b>
<b>Speed (M.P.H.):</b>	0 to 4
<b>* Range (variable):</b>	12-14 miles with U1 batteries
<b>Weight Limitation:</b>	200 lbs.

*\*NOTE: Range will vary with battery conditions, surface, terrain and operating weight.*

## PACKAGING

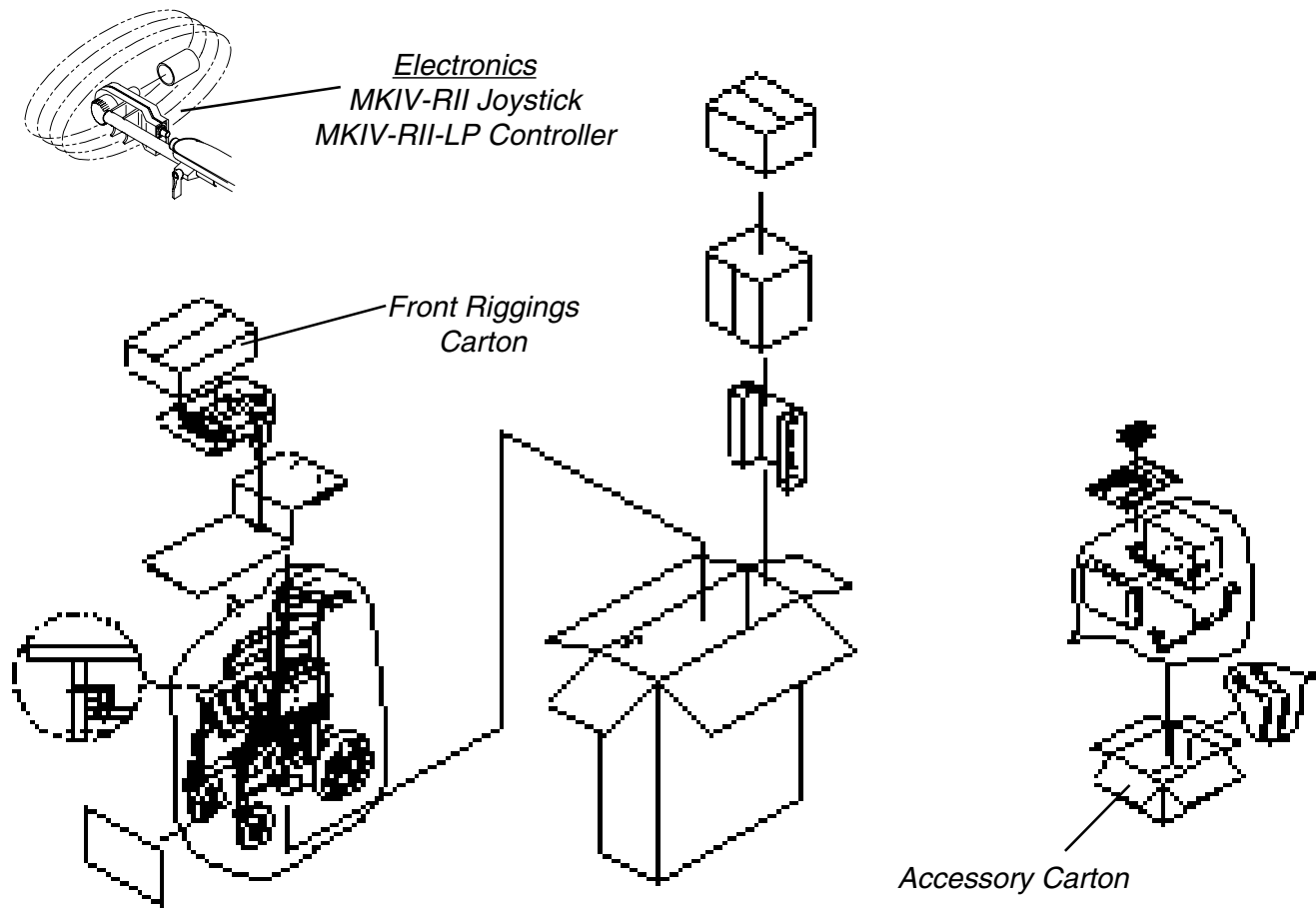

## HANDLING

### UNPACKING

1. Check for any obvious damage to the carton or its contents. If damage is evident, notify your Dealer/Carrier.
2. Remove all loose packing from the carton.
3. Carefully remove all components from the carton.

*NOTE: Unless the P7E is to be assembled immediately, retain cartons and packing materials for use in storing the wheelchair until assembly is required.*

### INSPECTION

1. Examine exterior of the P7E for nicks, dents, scratches or other damages. Inspect all components. If damage is evident, notify your Dealer/Carrier.

### STORAGE

1. Store the packaged/repackaged P7E in a dry area.
2. DO NOT place other objects on top of the packaged/repackaged wheelchair.

# SAFETY INSPECTION CHECK LIST

## SAFETY INSPECTION CHECKLIST

Initial adjustments should be made to suit your personal body structure and preference. Thereafter follow these maintenance procedures.

SAFETY INSPECTION

ITEM	INITIALLY	INSPECT/ ADJUST WEEKLY	INSPECT/ ADJUST MONTHLY	INSPECT/ ADJUST PERIODICALLY
<b>GENERAL - (MECHANICAL TROUBLESHOOTING)</b> Wheelchair rolls straight (no <b>excessive</b> drag or pull to one side).	X			X
<b>CLOTHING GUARDS - (PROCEDURE 3)</b> Ensure all fasteners are secure.	X			X
<b>ARMS - (PROCEDURE 3)</b> Secure but easy to release; adjustment levers engage properly. Adjustable height arms operate and lock securely.	X X			X X
<b>ARMRESTS - (PROCEDURE 3)</b> Inspect for rips in upholstery. Arm rest pad sits flush against arm tube.	X X			X X
<b>SEAT AND BACK UPHOLSTERY - (PROCEDURE 4)</b> Inspect for rips or sagging.	X			X
<b>* WHEEL LOCKS - (PROCEDURE 10)</b> Do not interfere with tires when rolling. Pivot points free of wear and looseness. Wheel locks easy to engage.	X X X		X X	X
<b>REAR WHEELS - (PROCEDURE 10)</b> Axle nut and wheel mounting nuts are secure. No excessive side movement or binding when lifted and rotated when disengaged.	X X		X	X X
<b>FRONT CASTERS - (PROCEDURE 10)</b> Inspect wheel/fork assembly for proper tension by spinning caster; caster should come to a gradual stop. Loosen/tighten locknut if wheel wobbles noticeably or binds to a stop. <b>CAUTION: As with any vehicle, the wheels and tires should be checked periodically for cracks and wear, and should be replaced when necessary.</b>	X X	X	X	
<b>CASTER/WHEEL/FORK/HEAD TUBE - (PROCEDURE 10)</b> Ensure all fasteners are secure.	X	X		
<b>TIRES - (PROCEDURE 10)</b> Inspect for flat spots and wear. If pneumatic tires check for proper inflation. <b>CAUTION: As with any vehicle, the wheels and tires should be checked periodically for cracks and wear, and should be replaced when necessary.</b>	X X	X X		
<b>CLEANING</b> Clean upholstery and armrests.	X			X

*NOTE: Twice a year take your wheelchair to a qualified dealer for a thorough inspection and servicing. Regular cleaning will reveal loose or worn parts and enhance the smooth operation of your wheelchair. To operate properly and safely, your wheelchair must be cared for just like any other vehicle. Routine maintenance will extend the life and efficiency of your wheelchair.*

### WARNING

**\*Wheel locks are an OPTION on this wheelchair, (you may order with or without wheel locks). Transfer to and from the wheelchair in the presence of a qualified healthcare professional to determine individual safety limits. Invacare strongly recommends ordering the wheel locks as an additional safeguard for the Action wheelchair user.**

# TROUBLESHOOTING

## TROUBLESHOOTING GUIDE MECHANICAL

CHAIR VEERS RIGHT	CHAIR VEERS LEFT	SLUGGISH TURN OR PERFORMANCE	CASTER FLUTTERS	SQUEAKS AND RATTLES	LOOSENESS IN CHAIR	SOLUTIONS
X	X	X				Check tires for correct and equal pressure.
		X	X	X	X	Check for loose stem nuts.
X	X	X				Check that both casters contact the ground at the same time.

## TROUBLESHOOTING GUIDE ELECTRICAL

SYMPTOM	PROBABLE CAUSE	SOLUTIONS
Batteries draw excessive current when charging.	Battery failure.  Electrical malfunction.	Check batteries for shorted cell. Perform Field Load Test (Troubleshooting). Replace if necessary (PROCEDURE 6).  Contact Dealer/Invacare for Service.
Battery indicator flashes the charge level is low —immediately after re-charge.	Battery failure.  Malfunctioning battery charger.  Electrical malfunction.	Check batteries for shorted cell. Perform Field Load Test (Troubleshooting). Replace if necessary (PROCEDURE 6).  Contact Dealer/Invacare for Service.  Poor connections between charger and wheelchair. Contact Dealer/Invacare for Service.
Battery indicator flashes the charge level is low—too soon after being re-charged.	Batteries not charged.  Weak batteries.  Electrical malfunction.	Have charger checked.  Check for shorted cell. Perform Field Load Test (Troubleshooting). Replace batteries if necessary (PROCEDURE 6).  Contact Dealer/Invacare for Service.
Motor “chatters” or runs irregular.	Electrical malfunction.	Contact Dealer/Invacare for Service.
Only one (1) rear wheel turns.	One clutch is disengaged.	Engage clutch (PROCEDURE 10).
Joystick erratic or does not respond as desired.	Electrical malfunction.  Controller Programed improperly.	Contact Dealer/Invacare for Service.  Reprogram controller (Refer to controller manual supplied with wheelchair).
Wheelchair does not respond to commands. Power indicator OFF—even after recharging.	Battery Box connectors are disconnected.  Poor battery terminal connection.  Battery Box fuse blown.  Electrical malfunction.	Reconnect all connectors.  Clean battery terminals (PROCEDURE 6).  Replace fuse.  Contact Dealer/Invacare for Service.

**NOTE:** For additional troubleshooting information and explanation of error codes, refer to the individual **CONTROLLER MANUAL** supplied with each wheelchair.

**CHECKING BATTERY CHARGE LEVEL (FIGURE 1)**

**TROUBLESHOOTING**

<b>WARNING</b>	
<p>Invacare recommends that the following procedures be performed by an Authorized Dealer or Qualified Service Technician.</p> <p>The following "Do's" and "Don'ts" are provided for your convenience and safety.</p>	
<b>DON'T</b>	<b>DO</b>
<p>Don't perform any installation or maintenance without first reading this manual.</p> <p>Don't perform installation or maintenance of batteries in an area that could be damaged by battery spills.</p> <p>Don't make it a habit to discharge batteries to the lowest level.</p> <p>Don't use randomly chosen batteries or chargers.</p> <p>Don't put new batteries into service before charging.</p> <p>Don't tip or tilt batteries.</p> <p>Don't use ordinary tap water.</p> <p>Don't overfill cells.</p> <p>Don't use uneven levels of distilled water in the cells.</p> <p>Don't tap on the clamps and terminals with tools.</p> <p>Don't mismatch your battery and chargers.</p>	<p>Read and understand this manual and any service information that accompanies a battery and charger before operating the wheelchair.</p> <p>Move the wheelchair to a work area before checking the fluid level, adding distilled water, cleaning terminals, or opening battery box(es).</p> <p>Recharge as frequently as possible to maintain a high charge level and extend battery life.</p> <p>Follow recommendations in this manual when selecting a battery or charger.</p> <p>Fully charge a new battery before using.</p> <p>Use a carrying strap to remove, move or install a battery.</p> <p>ONLY use distilled water to refill.</p> <p>Keep the liquid level in the cells at the "split ring" level.</p> <p>Maintain the liquid in all cells at the "split ring" level.</p> <p>Push the battery clamps on the terminals. Spread clamps wider if necessary.</p> <p>Use ONLY a GEL charger or GEL setting for a GEL or sealed battery and a regular charger or regular setting (wet) for regular batteries.</p>

**FIELD LOAD TEST**

Old batteries lose their ability to store and release power, due to increased internal resistance. This means that as you try to take power from the battery, some of that power is used up in the process of passing through the battery, resulting in less voltage at the posts. The more power drawn, the lower the voltage available. When this lost voltage drops the output 1.0 volts under load (2.0 for a pair), replace the batteries.

Testing under load is the only way to spot this problem. While special battery load testing equipment is available, it is costly and difficult to transport.

Use a digital voltmeter to check battery charge level at the charger connector. It is located on the side of the wheelchair frame.

*NOTE: READ the instructions CAREFULLY before using the digital voltmeter.*



1. Ensure that power is OFF.
2. Make sure battery is fully charged. An extremely discharged battery will exhibit the same symptoms as a bad one.
3. Remove the footrests from the wheelchair and place the front of the wheelchair against a wall, workbench or other stationary object.

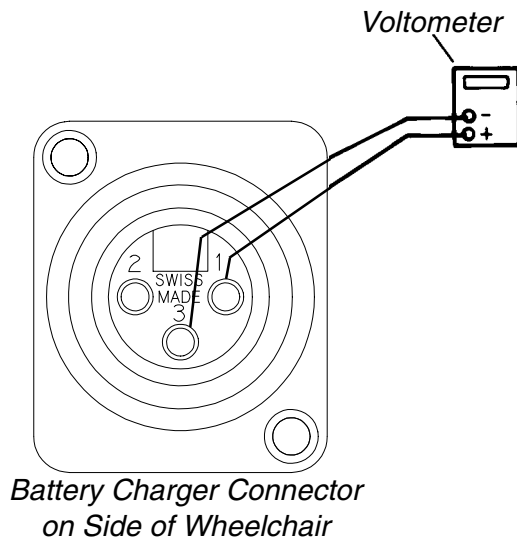

**FIGURE 1 - CONNECTING THE DIGITAL VOLTMETER TO THE WHEELCHAIR**

4. Place the voltmeter leads into the charger plug on the wheelchair. Most digital voltmeters are not affected by polarity, however, analog meters (meters with swinging needles) can be and should be used carefully. A good meter reading should be 25.5 to 26 VDC.
5. Have two (2) individuals (one [1] on each arm) apply as much downward pressure as possible on the arms of the wheelchair.
6. Turn the power ON and push the joystick forward, trying to drive the wheelchair through the stationary object. This puts a heavy load on the batteries as they try to push through the stationary object. Read the meter while the motors are straining to determine the voltage under load.

*NOTE: If the voltage drops to less than 23.5 volts from a pair of fully charged batteries while under load, they should be replaced regardless of the unloaded voltages.*

## USING HYDROMETER TO CHECK BATTERY CELLS (DIGITAL VOLTMETER NOT AVAILABLE) (LEAD ACID) (FIGURE 2)

### WARNING

Invacare recommends that the following procedure be performed by an Authorized Dealer or Qualified Service Technician.

NEVER smoke or strike a match near the batteries. If the caps of the battery cells are removed, NEVER look directly into them when charging the battery.

The use of rubber gloves and safety glasses is recommended when testing the battery cells.

When reading a hydrometer, DO NOT allow any liquid to come in contact with your eyes or skin. It is a form of acid and can cause serious burns, and in some cases, blindness. If you do get battery acid on you, flush the exposed areas with cool water immediately. If the acid comes into contact with eyes or causes serious burns, get medical help IMMEDIATELY.

The battery acid can damage your wheelchair, clothing, and household items. Therefore, take readings cautiously and only in designated areas.

Most batteries are not sold with instructions. However, warnings are frequently noted on the cell caps. Read them carefully.

### CAUTION

ONLY use distilled water when topping off the battery cells. Ordinary tap water will shorten the life of the battery.

1. Remove the battery box(es) from the wheelchair. Refer to INSTALLING/REMOVING BATTERY BOX(ES) in PROCEDURE 6 of this manual.
2. Remove the battery caps from the battery.
3. Squeeze the air from the hydrometer.
4. Place the hydrometer into a battery cell.

*NOTE: DO NOT fill hydrometer more than 3/4 full.*

5. Draw up sufficient acid to cover float balls.
6. Tap lightly to remove air bubbles.

## TROUBLESHOOTING

7. Number of floating balls indicates charge.

NUMBER OF FLOATING BALLS	
0	Discharged
1	25% Charged
2	50% Charged
3	75% Charged
4	100% Charged
* 5	Overcharged

\* Check charging system.

8. Flush the liquid back into the same cell after reading the float. Repeat this step until all cells have been properly read. A shorted or dead cell can be detected when it is the only cell that doesn't charge.

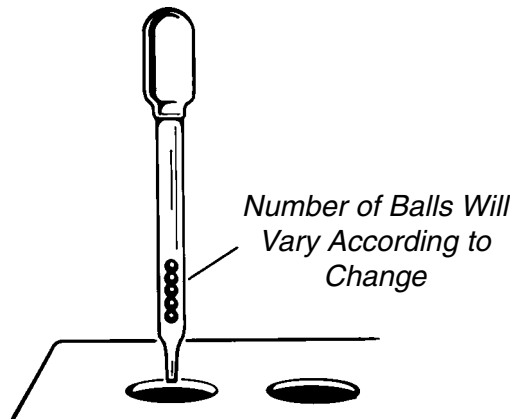

FIGURE 2 - USING A HYDROMETER

9. Flush the hydrometer in cold running water by allowing the water to rise into the hydrometer as far as possible. Do this several times to guard against burn damage.
10. Replace the battery caps.
11. Reinstall battery box(es). Refer to INSTALLING/REMOVING BATTERY BOX(ES) in PROCEDURE 6 of this Manual.

### MOTOR TESTING (FIGURE 3)

#### WARNING

Invacare recommends that the following procedures be performed by an Authorized Dealer or Qualified Service Technician.

1. On the 4-pin motor connector, locate the two (2) contacts in the red and black housings.

2. Set the digital multimeter to measure ohms.
3. Measure the resistance between the two (2) motor contacts.

*NOTE: A normal reading is between 1 and 5 ohms (W). A reading of 0 ohms (W) or in excess of 15 ohms (W) indicates a problem. High readings are generally caused by bad connections and/or damaged brushes. Contact authorized dealer or Invacare.*

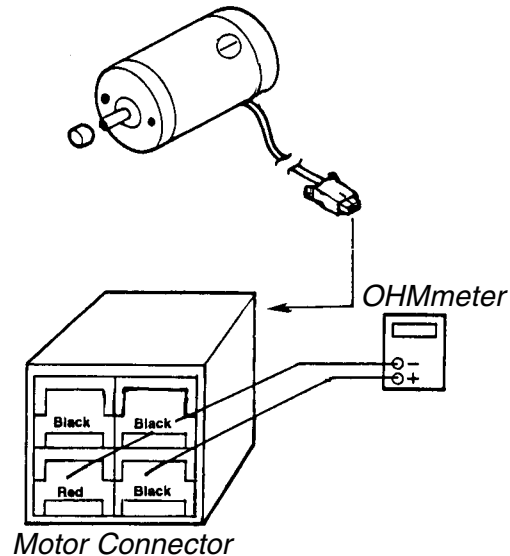

FIGURE 3 - MOTOR TESTING

### MOTOR BRUSH INSPECTION (FIGURE 4)

#### WARNING

Invacare recommends that the following procedures be performed by an Authorized Dealer or Qualified Service Technician.

Long End Cap Motors (Internally Concealed Brushes)

*NOTE: There are two (2) contact brushes on P7E motors.*

Motor brushes are located under the motor end cap. Remove the end cap, by removing the two (2) phillip screws.

*NOTE: It is very important to note which way the brush comes out of the motor. It MUST be placed into the motor exactly the same way to ensure good contact with the commutator.*

- Once the motor brush caps have been removed, pull the brushes out of the motor. The end of the brushes should be smooth and shiny and the spring should not be damaged or discolored. If one or both of the brushes are damaged, only the damaged or worn brushes need be replaced. It is very important that any time a brush is replaced, it must be "burned in". This is accomplished by running the motor for one hour in each direction with a half hour break in-between. This should also be done with little or no load on the motor, i.e., put the rear of the wheelchair up on blocks and run the wheelchair. A motor with only one brush replaced will only carry a small percentage of its rated load capacity until the NEW brush is burned in.

**Long End Cap Motor**

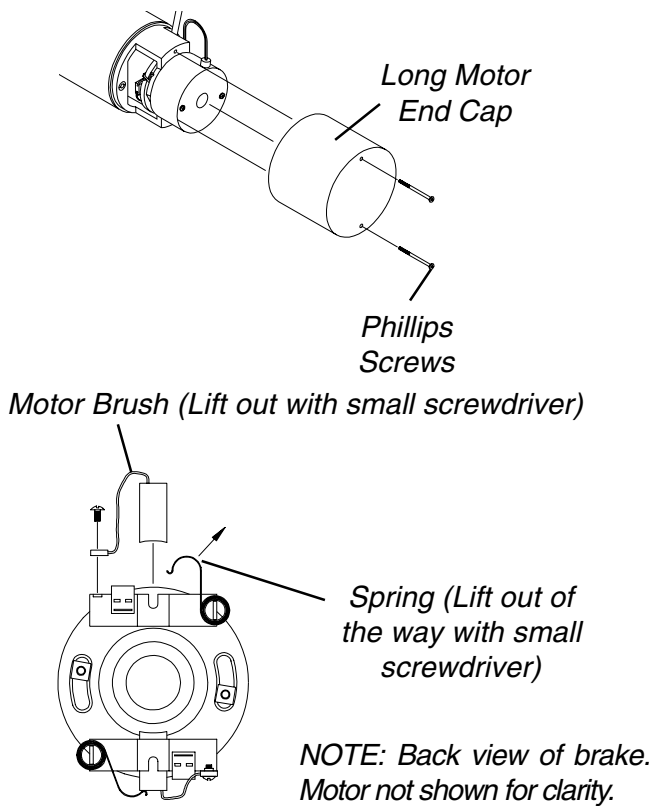

FIGURE 4 - MOTOR BRUSH INSPECTION

**ELECTROMECHANICAL PARKING BRAKE TESTING (FIGURE 5)**

**WARNING**

Invacare recommends that the following procedures be performed by an Invacare Dealer or Qualified Service Technician.

- On the four-pin motor connector, locate the side by side connectors in the black housings.
- Set the digital multimeter to read ohms.
- Measure the resistance between the two (2) brake contacts. A normal reading is 100 ohms (W). A reading of 0 ohms (W) or a very high reading; i.e., MEG ohms or O.L. (out of limit) indicates a shorted brake or an open connection respectively. If either condition exists, it is recommended that the motor be sent to Invacare Technical Service for inspection/repair.

**CAUTION**

A short circuited brake will damage the brake output section in the controller. DO NOT connect a bad electromechanical brake to a good controller module. A shorted electromechanical brake MUST be replaced.

NOTE: A bad motor can damage the controller module but a bad controller will NOT damage a motor.

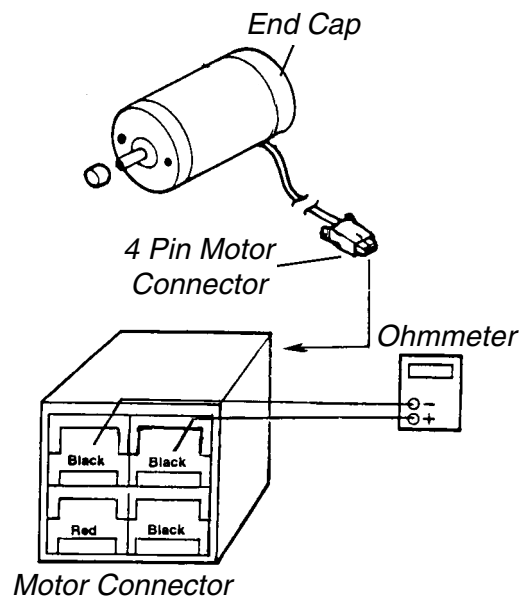

FIGURE 5 - PARKING BRAKE TESTING

*This Procedure includes the following:*

*Assembling the P7E*

ASSEMBLY

**ASSEMBLING THE P7E (FIGURE 1)**

**WARNING**

The following procedure should be performed only by an nvacare dealer or qualified technician.

*Install the footrests/legrests. Refer to SWINGAWAY FOOTREST ASSEMBLY INSTALLATION or ELEVATING LEGREST ASSEMBLY INSTALLATION in PROCEDURE 2 of this manual.*

*Install the battery tray and batteries. Refer to INSTALLING/REMOVING BATTERY TRAY and INSTALLING/REMOVING BATTERY BOX(ES) in PROCEDURE 6 of this manual.*

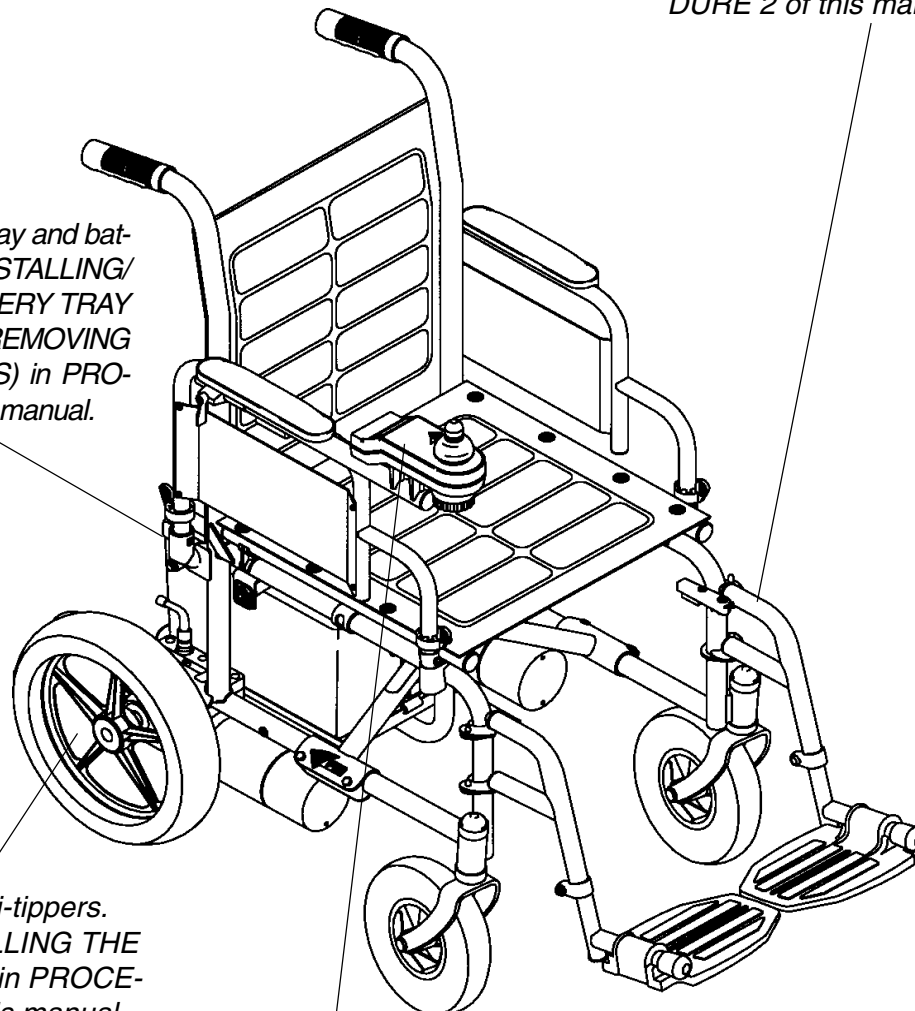

*Install the anti-tippers. Refer to INSTALLING THE ANTI-TIPPERS in PROCEDURE 10 of this manual.*

*Install the electronics. Refer to INSTALLING THE MKIV-R11-LP (LIMITED-PROGRAMMABLE) CONTROLLER in PROCEDURE 7 of this manual.*

**FIGURE 1 - ASSEMBLING THE P7E**

- This Procedure includes the following:*
- Swingaway Footrest Assembly Installation*
  - Swingaway Footrest Height Adjustment*
  - Heel Loop Replacement*
  - Elevating Legrest Assembly Installation*
  - Adjusting the Elevating Legrest Assembly*

**WARNING**

After making adjustments, always make sure that parts are properly tightened **BEFORE** using the wheelchair.

**SWINGAWAY FOOTREST ASSEMBLY INSTALLATION (FIGURE 1)**

1. Turn the footrest to the side (open footplate is perpendicular to wheelchair).
2. Install the hinge plates on the footrest onto the hinge pins on the wheelchair frame.
3. Push the footrest towards the inside of the wheelchair until it locks into place.

*NOTE: The footplate will be on the inside of the wheelchair when locked in place.*

4. Repeat STEPS 1-3 for the opposite footrest assembly.
5. To release the footrest, push the footrest release lever inward, rotate footrest outward.

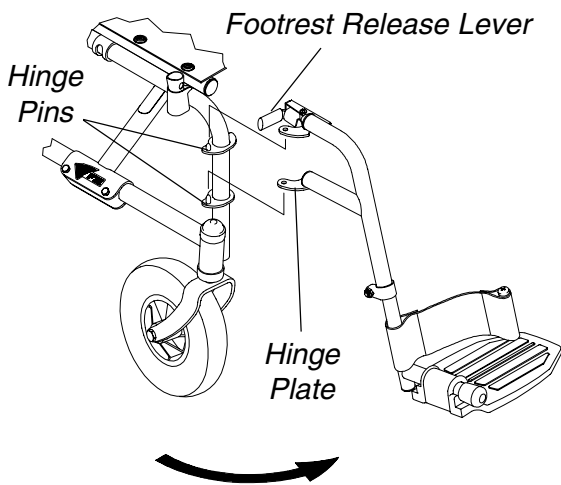

**FIGURE 1 - SWINGAWAY FOOTREST ASSEMBLY INSTALLATION**

**SWINGAWAY FOOTREST HEIGHT ADJUSTMENT (FIGURE 2)**

1. Remove any accessory from the footrest(s).
2. Remove the footrest from the wheelchair. Refer to **INSTALLING/REMOVING FOOTRESTS** in this procedure of the manual.

*NOTE: Lay the footrest on a flat surface to simplify this procedure.*

3. Remove the hex bolt, coved washers and locknut that secure the lower footrest to the footrest support.
4. Reposition the lower footrest to the desired height.
5. Reinstall the hex bolt, coved washers and locknut that secure the lower footrest to the footrest support and tighten securely.
6. Repeat STEPS 1-5 for the opposite side of the wheelchair footrest, if necessary.
7. Reinstall the footrest(s) onto the wheelchair. Refer to **INSTALLING/REMOVING FOOTRESTS** in this procedure of the manual.
8. Reinstall any accessory onto the footrest(s).

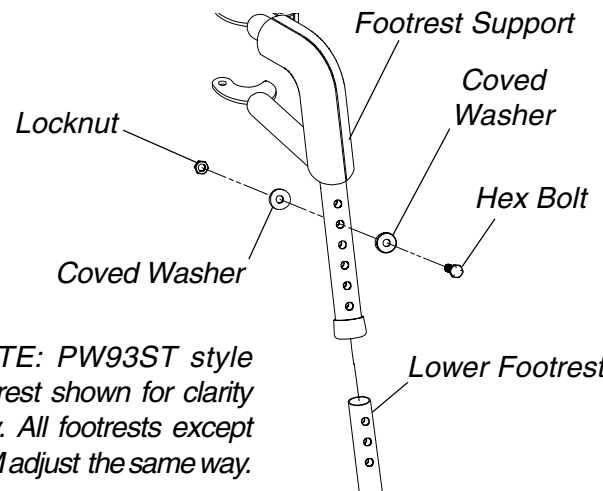

*NOTE: PW93ST style footrest shown for clarity only. All footrests except 93M adjust the same way.*

**FIGURE 2 - SWINGAWAY FOOTREST HEIGHT ADJUSTMENT**

**HEEL LOOP REPLACEMENT (FIGURE 3)**

1. Note the position of the hex bolt, covered washers and locknut for reinstallation.
2. Remove the hex bolt, covered washers and locknut that secure the lower footrest to the footrest support.
3. Remove the lower footrest.
4. Remove the phillips bolt, spacer and locknut that secure the existing heel loop to the lower footrest.
5. Slide the existing heel loop off the lower footrest.
6. Replace heel loop.
7. Reverse STEPS 1-6 to reassemble.

*NOTE: When securing the heel loop to the lower footrest, tighten the phillips screw and locknut until the spacer is secure.*

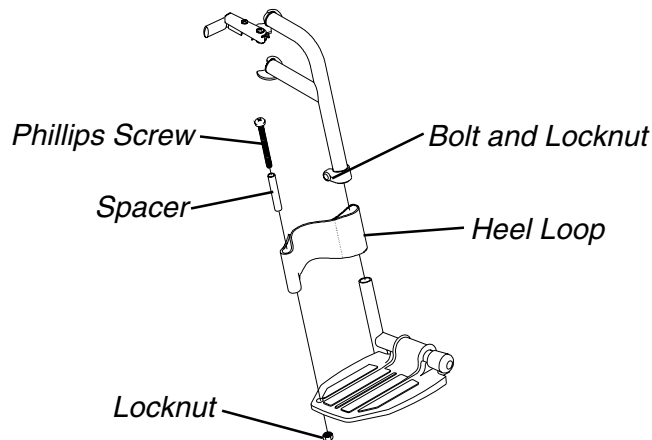

FIGURE 3 - HEEL LOOP REPLACEMENT

**ELEVATING LEGREST ASSEMBLY INSTALLATION (FIGURES 4 AND 5)**

1. Insert the lower footrest assembly into the calypad assembly and secure it with the bolt and locknut (FIGURE 4).

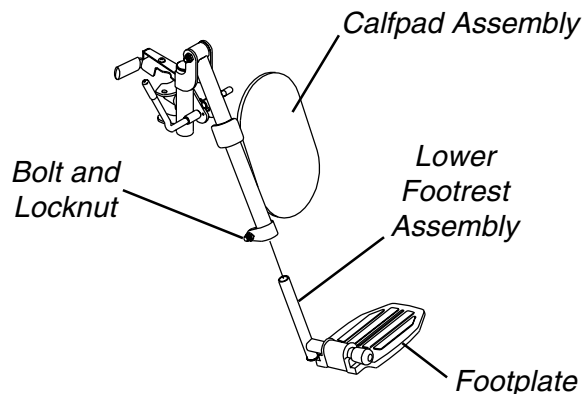

FIGURE 4 - INSTALLING LOWER FOOTREST ASSEMBLY

2. Place legrest assembly on the outside of the wheelchair and install the hinge plates onto the hinge pins on the wheelchair frame (FIGURE 5).
3. Rotate legrest assembly toward the inside of the wheelchair until it locks in place (FIGURE 5).

*NOTE: The footplate will be on the inside of the wheelchair when locked in place.*

4. Repeat this procedure for other legrest assembly.
5. After seated in wheelchair, adjust footrest to correct height by loosening the nut and sliding the inner tube up or down until desired height is achieved.
6. To release the legrest, push the legrest release handle toward the inside of the wheelchair (facing the front of the wheelchair) and swing the legrest assembly to the outside of the wheelchair.

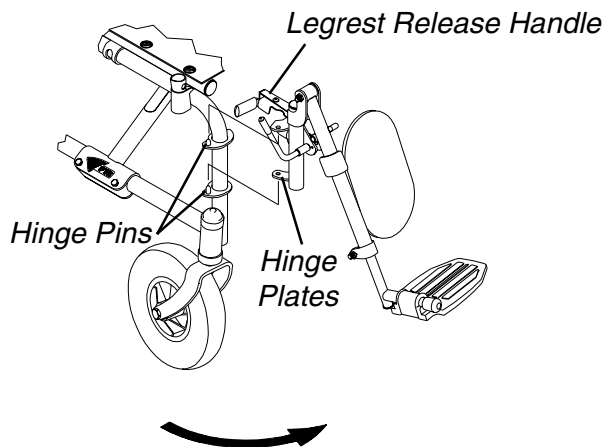

FIGURE 5 - INSTALLING LEGREST ASSEMBLY ONTO THE WHEELCHAIR

## ADJUSTING THE ELEVATING LEGREST ASSEMBLY (FIGURE 6)

1. To adjust the elevating legrest, raise legs until the desired height is obtained.
2. To reposition legrest to normal position, support leg with one (1) hand and push release lever downward with other hand.
3. To adjust the calfpad, turn pad towards the outside of the wheelchair.
4. Slide the calfpad up or down until the desired position is obtained.
5. To secure the calfpad, turn the calfpad towards the inside of the wheelchair.

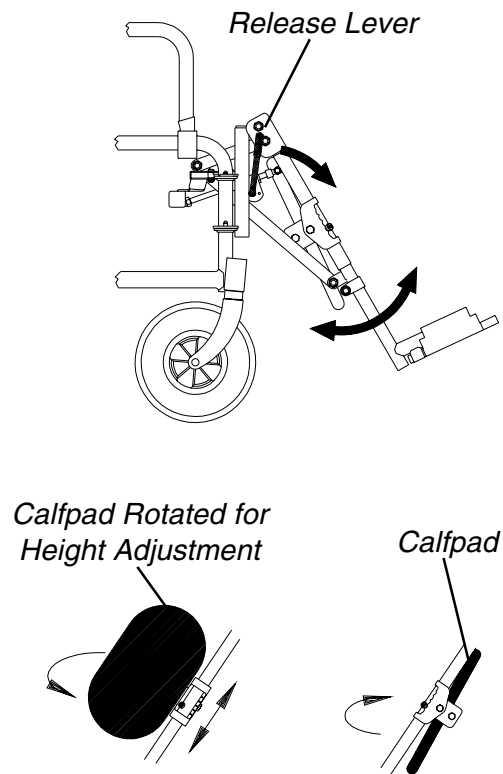

FIGURE 6FC - ADJUSTING ELEVATING LEGREST ASSEMBLY

**This Procedure includes the following:**  
**Adjusting Armrest Height, Removing or Replacing Armrests**  
**Replacing/Repositioning Desk/Full Length Armrest Pad/Plastic Snap**  
**Replacing Clothing Guards (Fixed Height Arms Only)**

**WARNING**  
 After adjustments and before use make sure all attaching hardware is securely tightened and torqued to specifications.

**ADJUSTING ARMREST HEIGHT, REMOVING OR REPLACING ARMRESTS (FIGURE 1)**

**WARNING**  
 Make sure the locking mechanism is secured before using the wheelchair.

**Adjusting Armrest Height**

1. Unlock the armrest by flipping the height adjustment lever on the top front of the armrest to the UP (HORIZONTAL) position.
2. Adjust armrest to desired height.

*NOTE: The height adjustment lever MUST be in the unlocked position when placing armrest into the arm assembly.*

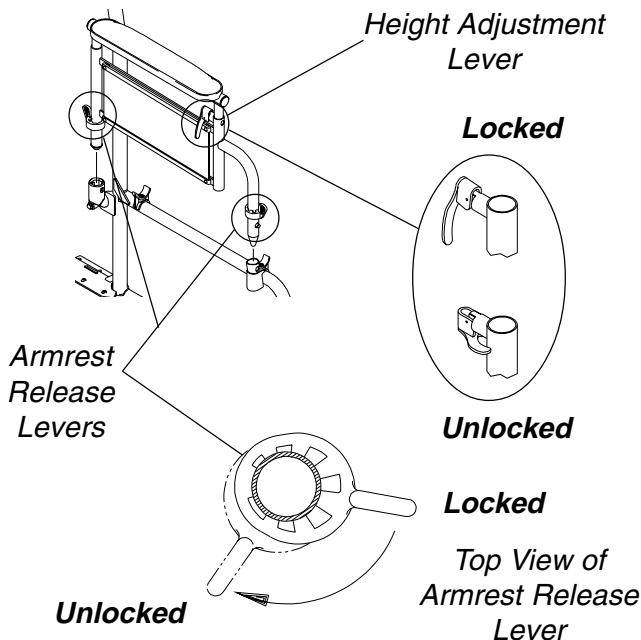

**FIGURE 1 - ADJUSTING ARMREST HEIGHT, REMOVING OR REPLACING ARMRESTS**

3. Lock the armrest by pressing the height adjustment lever into the DOWN (VERTICAL) position when the desired height is achieved.

**Removing Armrests**

1. Unlock the armrest by rotating the armrest release lever towards the outside of the wheelchair.
2. To remove the armrest from the wheelchair, pull the armrest straight up/out of the arm sockets.

**Replacing Armrests**

1. Insert the armrest into the arm sockets on the wheelchair.

*NOTE: Armrest release levers MUST be in the unlocked position when placing armrest into the arm sockets.*

2. Lock the armrests by rotating the armrest release lever towards the inside of the wheelchair.

**REPLACING/REPOSITIONING DESK/FULL LENGTH ARMREST PAD/PLASTIC SNAP (FIGURE 2)**

**Replacing**

*NOTE: If replacing the armrest pad on the armrest that the controller is mounted on, make sure the plastic snap is BETWEEN the two mounting holes on the armrest.*

1. Remove the phillips screws that secure the armrest pad(s) to the armrest assembly.
2. Replace armrest pad and securely tighten with the existing phillips screws.

**Repositioning**

*NOTE: If the controller position is changed from the right side of the wheelchair to the left side or vice versa, the armrest pad and plastic snap must be repositioned as well.*

1. Remove the phillips screws that secure the armrest pad(s) to the armrest assembly.
2. Remove the plastic snap from the armrest.



3. Reposition the plastic snap on the opposite armrest. Make sure the plastic snap is positioned between the two (2) mounting holes on the armrest.
4. Reposition the armrest pads on the opposite side of the wheelchair.
5. Position the armrest pads on the armrests and securely tighten with the existing phillips screws

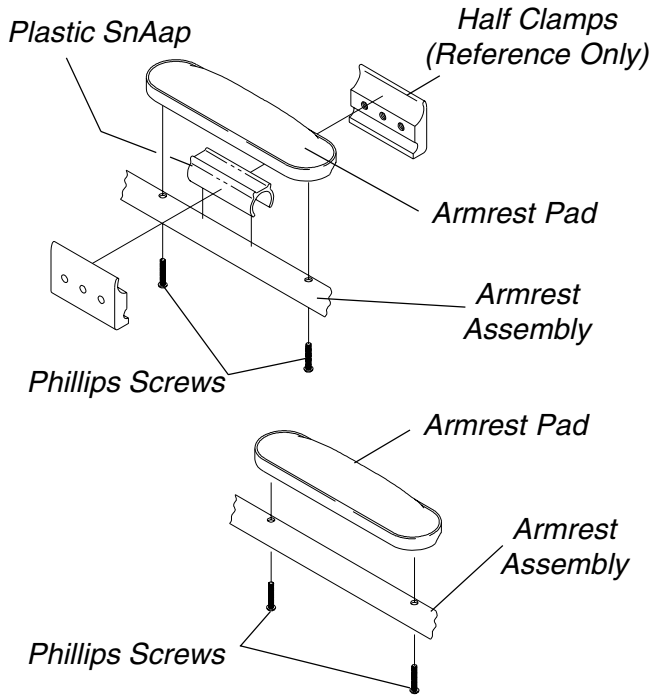

FIGURE 2 - REPLACING/REPOSITIONING DESK/  
FULL LENGTH ARMREST PAD/PLASTIC SNAP

**REPLACING CLOTHING GUARDS  
(FIXED HEIGHT ARMS ONLY)  
(FIGURE 3)**

1. Remove the four (4) screws that secure the existing clothing guard to the armrest assembly.
2. Replace the existing clothing guard with the new clothing guard and securely tighten with the existing hardware.

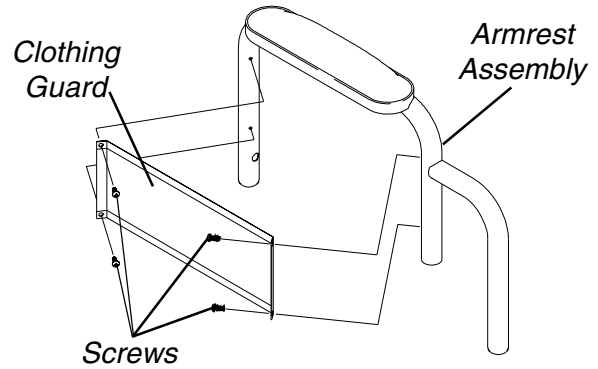

FIGURE 3 - REPLACING CLOTHING GUARDS  
(FIXED HEIGHT ARMS ONLY)

A  
R  
M  
S

*This Procedure includes the following:*

*Replacing the Seat Upholstery*

*Replacing the Back Upholstery*

*Replacing the Seat Restraint*

**WARNING**

After making adjustments, always make sure that parts are properly tightened BEFORE using the wheelchair.

**REPLACING THE SEAT UPHOLSTERY (FIGURE 1)**

1. Remove the eight (8) phillips screws that secure the existing seat upholstery to the crossbraces.
2. Remove the existing seat upholstery from the crossbraces.
3. Line up mounting holes in new seat upholstery with mounting holes in the crossbraces.
4. Securely tighten with existing phillips screws.

*NOTE: Clean upholstery with warm DAMP cloth and mild detergent to remove superficial soil.*

**WARNING**

Laundrying or moisture will reduce flame retardation of the upholstery.

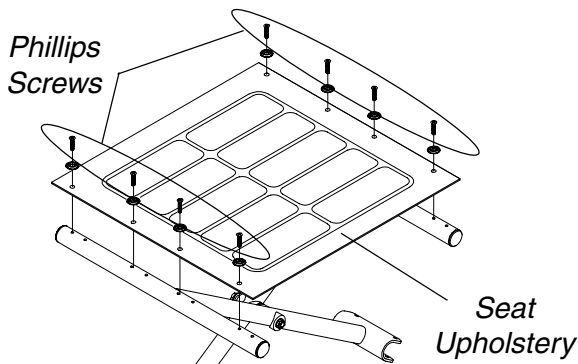

FIGURE 1 - REPLACING THE SEAT UPHOLSTERY

**REPLACING THE BACK UPHOLSTERY (FIGURE 2)**

1. Remove the eight (8) phillips screws and washers that secure the back upholstery to the back canes.
2. Position the new back upholstery on the back canes. Make sure the mounting holes in the back upholstery line up with the mounting holes in the back canes.

3. Secure the new back upholstery to the back canes with the eight (8) phillips screws and washers.

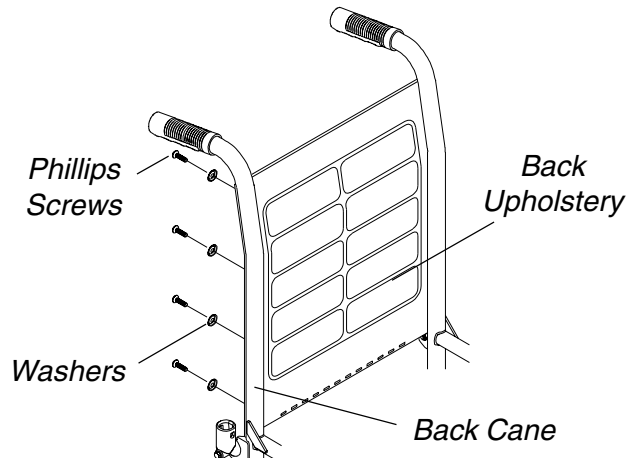

FIGURE 2 - REPLACING THE BACK UPHOLSTERY

**REPLACING THE SEAT RESTRAINT (FIGURE 3)**

1. Remove the two (2) rear phillips screws and washers that secure the seat upholstery and seat restraint to the crossbraces.
2. Remove the two (2) halves of the seat restraint from the crossbraces.
3. Reposition the two (2) new seat restraint halves between the seat upholstery and the crossbraces.
4. Reinstall the rear phillips screws and washers that secure the seat upholstery and seat restraint to the crossbraces.

*NOTE: Washer is positioned on top of the seat upholstery.*

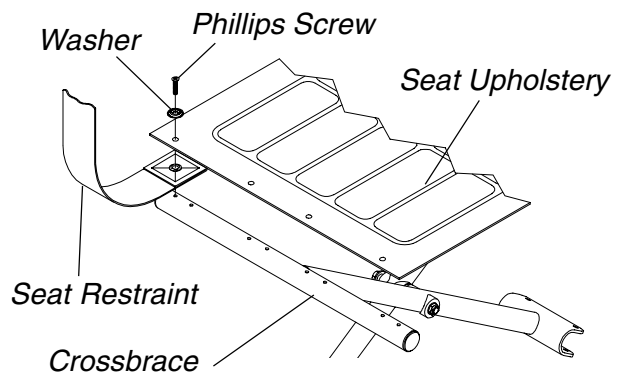

FIGURE 3 - REPLACING THE SEAT RESTRAINT

*This Procedure includes the following:*

*Adjusting Seat Width*

*Adjusting Seat Depth*

**WARNING**

The following procedures should only be performed by an Invacare dealer or qualified technician.

After making adjustments, always make sure that parts are properly tightened BEFORE using the wheelchair.

**ADJUSTING SEAT WIDTH (FIGURE 1)**

1. Remove the battery box(es) and battery tray from the wheelchair. Refer to INSTALLING/REMOVING BATTERY BOX(ES) and INSTALLING/REMOVING BATTERY TRAY in PROCEDURE 6 of this manual.
2. Remove the existing back and seat upholstery from the wheelchair. Refer to REPLACING THE BACK UPHOLSTERY and REPLACING THE SEAT UPHOLSTERY in PROCEDURE 4 of this manual.

*NOTE: If adjusting the seat width of the wheelchair, the back and seat upholstery MUST be changed as well.*

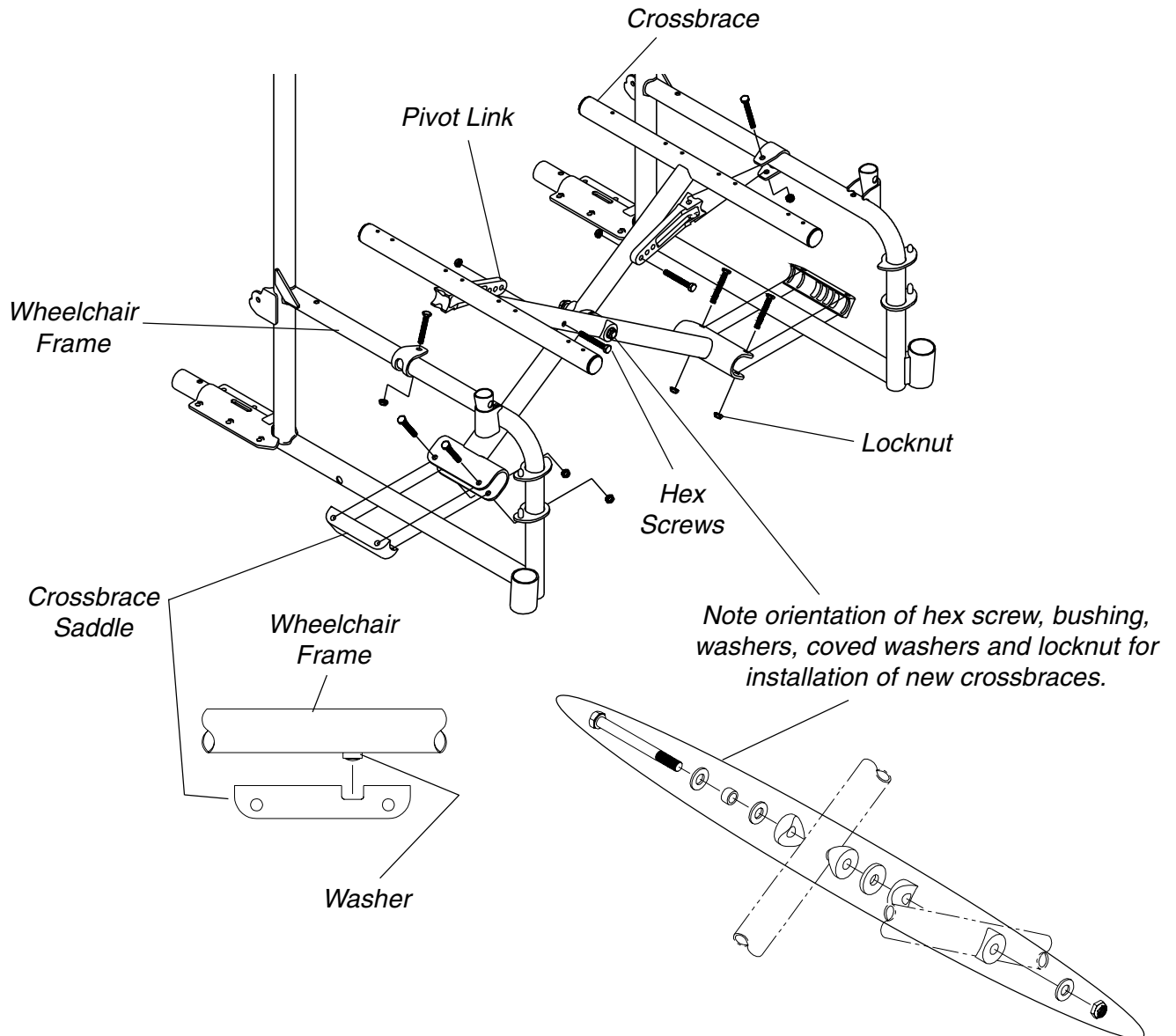

**FIGURE 1 - ADJUSTING SEAT WIDTH**

3. Remove the hex screws and locknuts that secure the two (2) pivot links to the wheelchair frame and crossbraces.
4. Remove the hex screws, locknuts and crossbrace saddles that secure the bottom of the two (2) crossbraces to the wheelchair frame.
5. Remove the hex screw, coved spacers, washers and locknut that secure the two (2) existing crossbraces together.

*NOTE: Note coved spacer, washer and locknut order for reinstallation.*

6. Assemble the two (2) new crossbraces together. Refer to FIGURE 1 for hardware orientation.
7. Reinstall the hex screws, locknuts and crossbrace saddles that secure the bottom of the two (2) new crossbraces to the wheelchair frame.

*NOTE: Position crossbrace saddle on wheelchair frame using the washer on the underside of wheelchair frame as a reference. Refer to FIGURE 7.*

8. Reinstall the hex screws and locknuts that secure the pivot links to the wheelchair frame and crossbraces.
9. Install the new back and seat upholstery onto the wheelchair. Refer to REPLACING THE BACK UPHOLSTERY and REPLACING THE SEAT UPHOLSTERY in PROCEDURE 4 of this manual.
10. Reinstall the battery tray and battery box(es)/batteries onto the wheelchair. Refer to INSTALLING/REMOVING BATTERY TRAY and INSTALLING/REMOVING BATTERY BOX(ES) in PROCEDURE 6 of this manual.

### ADJUSTING SEAT DEPTH (FIGURE 2)

1. Remove the existing seat upholstery from the wheelchair. Refer to REPLACING THE SEAT UPHOLSTERY in PROCEDURE 4 of this manual.

*NOTE: If adjusting the seat depth of the wheelchair, the seat upholstery MUST be changed as well.*

2. Remove the two (2) plug buttons from the ends of the crossbraces that are towards the front of the wheelchair.

*NOTE: The two (2) plug buttons will be used in the ends of the seat extensions.*

3. Install the two (2) seat extension tubes into the ends on the crossbraces. Make sure the notches and mounting holes are pointing up.
4. Install the new seat upholstery onto the wheelchair. Make sure to line up the notches and mounting holes in the seat extension tubes with the new seat upholstery. Refer to REPLACING THE SEAT UPHOLSTERY in PROCEDURE 4 of this manual.
5. Install plug buttons into the ends of the seat extension tubes.

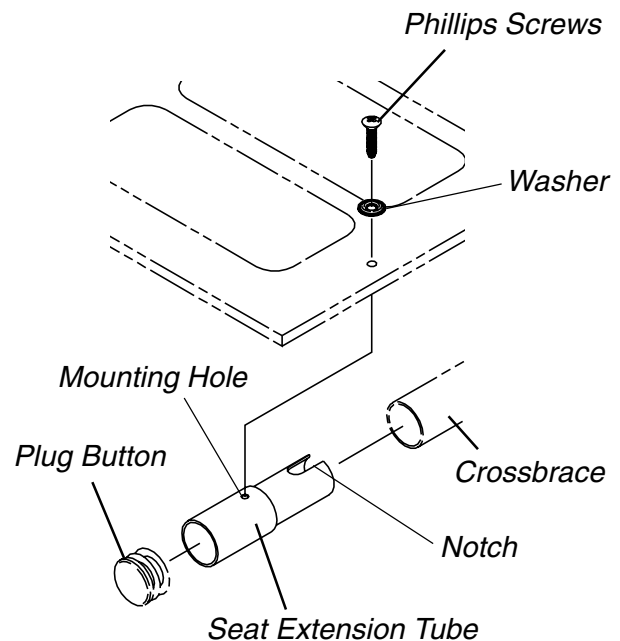

FIGURE 2 - ADJUSTING SEAT DEPTH

**This Procedure includes the following:**  
**Installing/Removing Battery Tray**  
**Installing/Removing Batteries from/into Single Battery Box and Optional Dual Battery Boxes**  
**Removing/Installing Battery Box(es)**  
**When to Charge the Batteries**  
**Charging the Batteries**

**WARNING**  
 During use and charging, unsealed batteries will vent hydrogen gas which is explosive in the right concentration with air.

*NOTE: The hex screws will be positioned in the correct mounting holes for the corresponding width of the wheelchair.*

2. Secure the hanger brackets to the battery tray in the mounting holes that the hex screws are mounted into.
3. Attach the key slot bracket located at the front of the battery tray over the crossbrace bolt bushing under the seat upholstery of the wheelchair.
4. Attach the hanger brackets to the support tubes on the wheelchair frame.

*NOTE: To remove the battery tray from the wheelchair, reverse the above procedure.*

**INSTALLING/REMOVING BATTERY TRAY (FIGURE 1)**

1. Remove the battery tray from the packaged container.

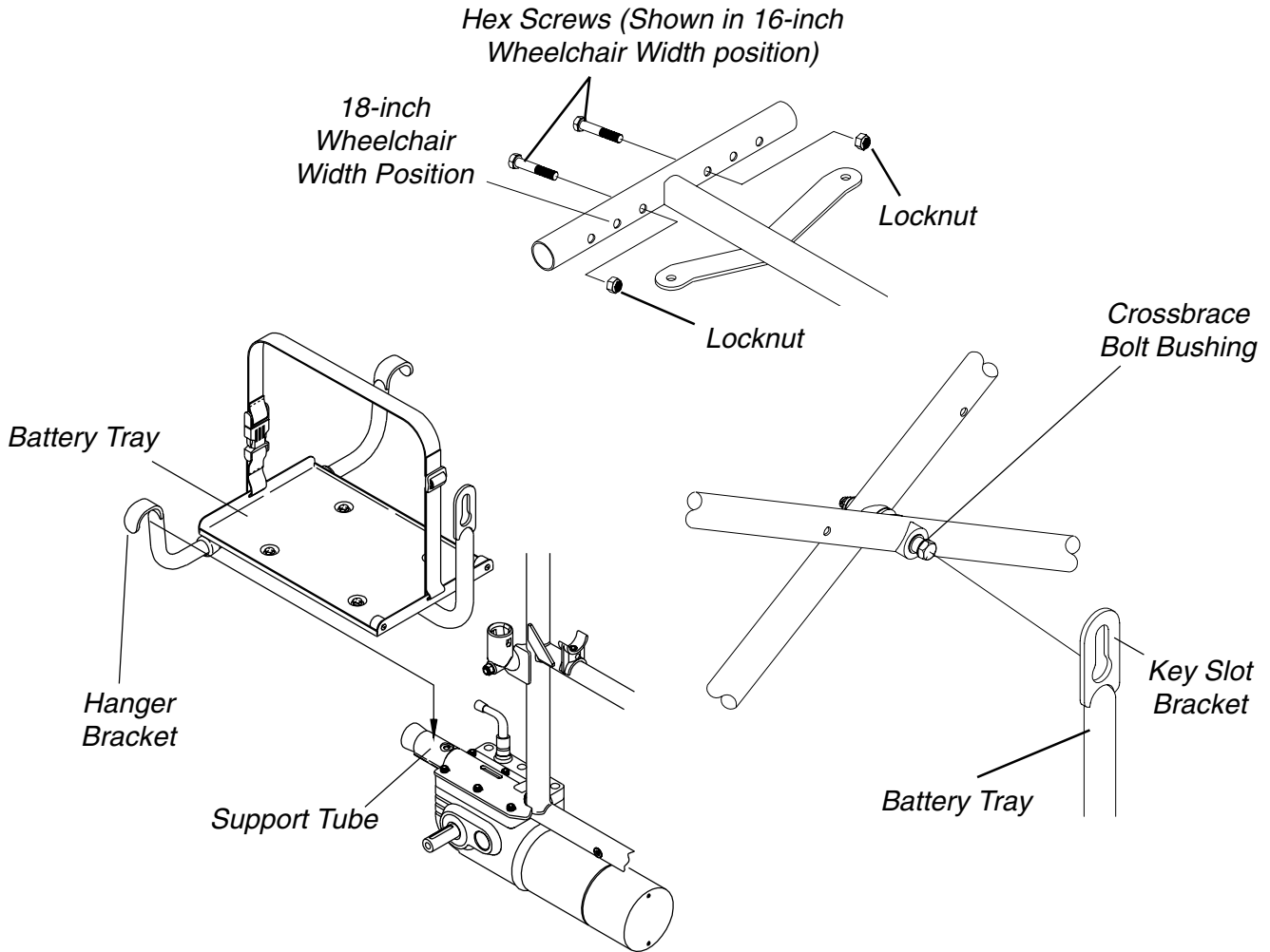

**FIGURE 1 - INSTALLING/REMOVING BATTERY TRAY**

## INSTALLING AND/OR REMOVING BATTERIES

*NOTE: Invacare recommends that both batteries be replaced if one (1) battery is defective.*

### RECOMMENDED BATTERY TYPES

BATTERIES

#### GENERAL WARNINGS

Failure to use the correct battery size and/or voltage may cause damage to your wheelchair and give you unsatisfactory performance.

Make sure power to the wheelchair is OFF before performing this procedure.

The use of rubber gloves and safety glasses is recommended when working with batteries.

After ANY adjustments, repair or service and BEFORE use, make sure all attaching hardware is tightened securely -otherwise, serious personal injury, damage to the wheelchair and/or damage to surrounding property may occur.

#### CAUTION

DO NOT tip the batteries. Keep the battery(ies) in an upright position.

The warranty and performance specifications contained in this manual are based on the use of deep cycle gel cell or sealed lead acid batteries. Invacare strongly recommends their use as the power source for this unit.

SEAT WIDTH	QTY	VOLTS	BCI STOCK	REMARKS
16/18-inches	2	12	U1	Deep Cycle

*NOTE: Have the following tools available:*

TOOLS	QTY	COMMENTS
7/16-inch (6 pt) Box Wrench	1	Not Supplied
3/8-inch (6 pt) Box Wrench	1	Not Supplied
Diagonal Cutters	1	Not Supplied

*NOTE: Charge batteries daily. It is critical not to let them run low at any time.*

*NOTE: This procedure provides instructions for **Initially Installing Batteries into the Battery Box** and for future instruction on **Removing/Installing the Batteries into/from Battery Box**, refer to the Summary of Installation below.*

### SUMMARY OF INSTALLATION - SINGLE BATTERY BOX

1. Perform the sections indicated, in order, to properly remove and/or install the batteries:

#### Initial Installation of Batteries into Battery Box

- A. Remove single battery box from wheelchair.
- B. N/A
- C. Installing batteries into single battery box
- D. N/A
- E. Installing Terminal Caps
- F. Connecting Battery Cables.
- G. Securing terminal caps to battery terminals/ posts.
- H. Install single battery box into wheelchair.

#### Removing/Installing the Batteries into/from Battery Box

- A. Remove single battery box from wheelchair.
- D. Disconnecting Battery Cables.
- B. Remove the batteries from the single battery box
- C. Install the batteries into the single battery box.
- F. Connecting Battery Cables.
- G. Securing terminal caps to battery terminals/ posts.
- H. Install single battery box into wheelchair.

**SECTION A - REMOVE SINGLE BATTERY BOX FROM WHEELCHAIR (FIGURE 2)**

1. Place wheelchair in a well ventilated area where work can be performed without risking damage to carpeting or floor covering.
2. Verify that the ON/OFF switch on the joystick is in the OFF position.
3. Disconnect the battery cables of the battery box from the battery connectors on the wheelchair frame.
4. Disconnect the battery box retaining strap clip.
5. Remove battery box from wheelchair.

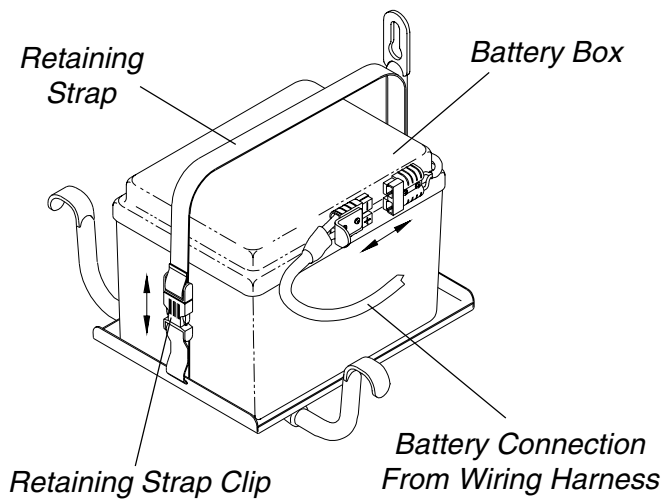

**FIGURE 2 - REMOVING BATTERIES FROM SINGLE BATTERY BOX**

**SECTION B - REMOVING THE SINGLE BATTERIES FROM THE BATTERY BOX (FIGURE 3)**

**WARNING**  
Always use a battery lifting strap when lifting a battery. It is the most convenient method and assures that the battery acid will not spill (wet cell batteries). It also helps to prolong the life of the battery.

*NOTE: Refer to the battery manufacturer for the proper lifting strap and/or battery tools for U1 battery removal/installation.*

1. Clean battery terminals. Refer to CLEANING BATTERY TERMINALS in this section.
2. Secure battery lifting strap or battery tools to one (1) battery and remove from battery box. Repeat for other battery.

*NOTE: If there is battery acid in the bottom or on the sides of the battery box or battery, apply baking soda to these areas to neutralize the battery acid. Before reinstalling the NEW or existing battery(ies), clean the baking soda from the battery box(es) or battery(ies).*

**Cleaning Battery Terminals**

**WARNING**  
Most batteries are not sold with instructions. However, warnings are frequently noted on the cell caps. Read them carefully.  
DO NOT allow the liquid in the battery to come in contact with skin, clothes or other possessions. It is a form of acid and harmful or damaging burns may result. Should the liquid touch your skin, wash the area immediately and thoroughly with cool water. In serious cases or if eye contact is made, seek medical attention IMMEDIATELY.  
NEVER smoke or strike a match near the batteries. If the caps of the battery cells are removed, NEVER look directly into them when charging the battery.

1. Examine the battery clamps and terminals for corrosion.
2. Verify that the plastic caps are in place over the battery cell holes.
3. Clean the terminals and inside the battery clamps by using a battery cleaning tool, wire brush, or medium grade sand paper.

*NOTE: Upon completion, these areas should be shiny, not dull.*

4. Carefully dust off all metal particles.

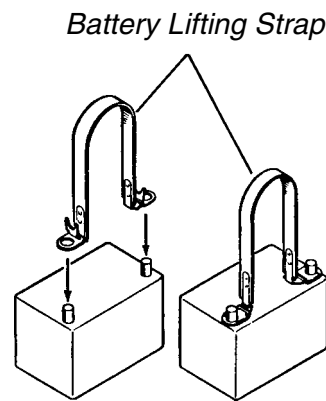

**FIGURE 3 - REMOVING THE BATTERIES FROM THE SINGLE BATTERY BOX**

**SECTION C - INSTALLING THE BATTERIES INTO THE SINGLE BATTERY BOX (FIGURE 3)**

*NOTE: Refer to the battery manufacturer for the proper lifting strap and/or battery tools for U1 battery removal/installation.*

**WARNING**

U1 batteries in a single battery box **MUST** be positioned in the battery box as shown in FIGURE 1 for proper battery cable connection to battery box top.

Always use a battery lifting strap when lifting a battery. It is the most convenient method and assures that the battery acid will not spill (wet cell batteries). It also helps to prolong the life of the battery.

Some battery manufacturers mold a carrying strap and/or hold down flanges directly into the battery case. Batteries which interfere with the battery box cannot be used for these applications. Attempting to "wedge" a battery into a battery box may damage the box and/or the battery. Refer to DETAIL "A" in FIGURE 3.

1. Secure battery lifting strap or battery tools to one (1) battery and place battery in front area of battery box.
2. Secure battery lifting strap or battery tools to remaining battery and place battery in rear area of battery box.

DETAIL "A"

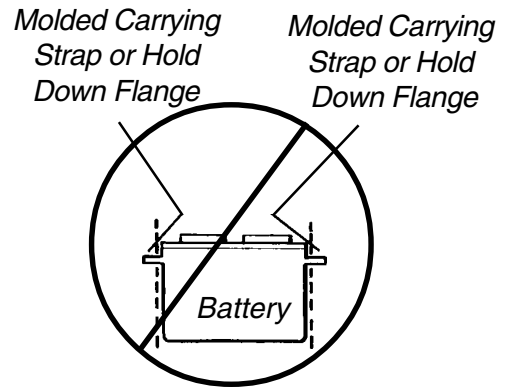

Battery Lifting Strap

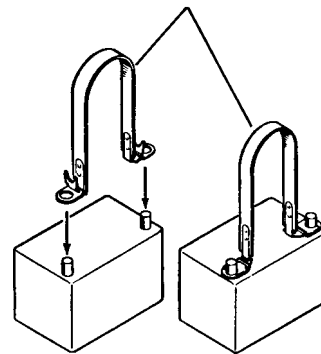

*This side faces the front of the wheelchair*

FRONT AREA OF BATTERY BOX

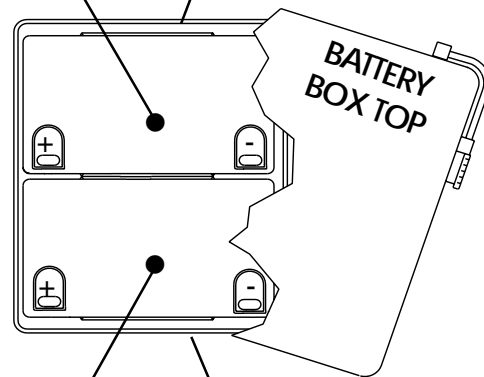

REAR AREA OF BATTERY BOX

*This side faces the rear of the wheelchair*

**FIGURE 3 - REMOVING/INSTALLING THE BATTERIES FROM/INTO SINGLE BATTERY BOX**



**SECTION D - DISCONNECT BATTERY CABLE(S) FROM BATTERY(IES)**

**WARNING**

NEVER allow any of your tools and/or battery cable(s) to contact BOTH battery terminal(s)/post(s) at the same time. An electrical short may occur and serious personal injury, damage to the wheelchair and/or damage to surrounding property may occur.

1. Carefully lift up existing U1 battery box top to expose the underlying battery cables.
2. Cut the tie-wraps that secure the orange and gray caps to the battery terminals/posts. (DETAIL "B" in FIGURE 4)
3. Slide the terminal caps up on the battery cable. (DETAIL "C" in FIGURE 4)
4. Disconnect the battery cable (jumper) terminal end from NEGATIVE (-) battery terminal/post of REAR battery. (DETAIL "D" in FIGURE 5)

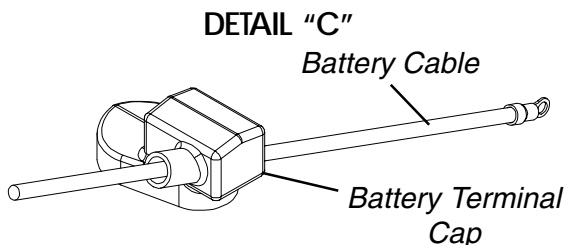
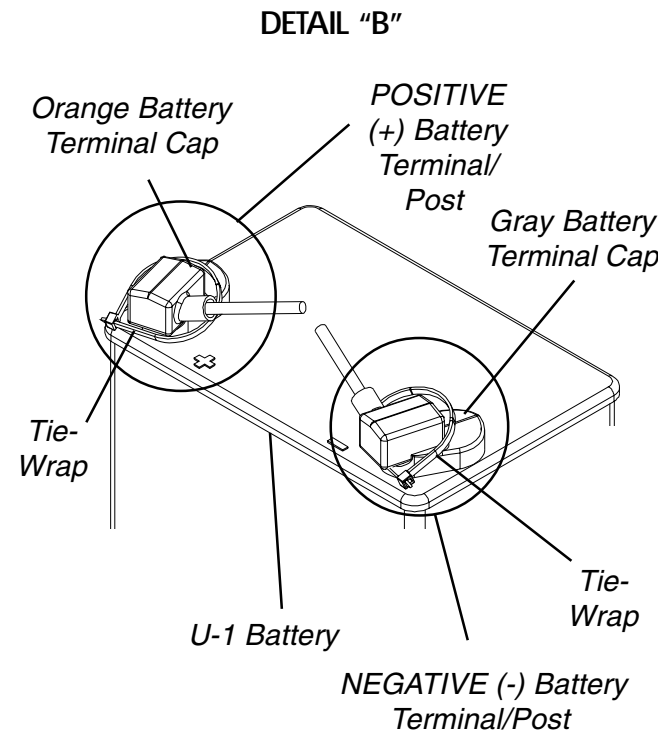

FIGURE 4 - REMOVING/INSTALLING THE BATTERIES FROM/INTO SINGLE BATTERY BOX

5. Disconnect the battery cable (jumper) terminal end from POSITIVE (+) battery terminal/post of FRONT battery. (DETAIL "D" in FIGURE 5)
6. Disconnect NEGATIVE (-) BLACK battery cable extending from battery box top from NEGATIVE (-) battery terminal/post of FRONT battery. (DETAIL "E" in FIGURE 5)
7. Disconnect POSITIVE (+) RED battery cable extending from box top from POSITIVE (+) battery terminal/post of REAR battery. (DETAIL "E" in FIGURE 5)

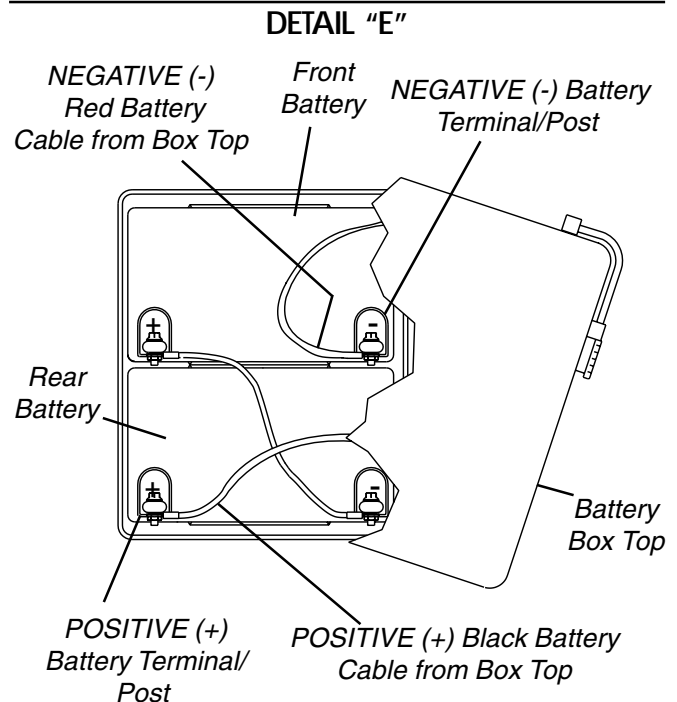
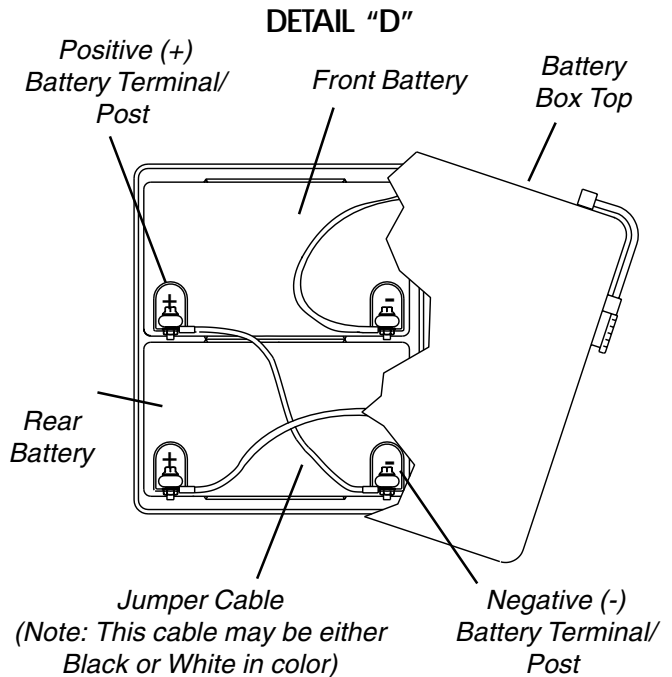

FIGURE 5 - DISCONNECT BATTERY CABLE(S) FROM BATTERY(IES)

**SECTION E - INSTALLING TERMINAL CAPS (FIGURE 6)**

*NOTE: Refer to INSTALLATION WARNINGS and CAUTIONS in the SAFETY SUMMARY of this instruction sheet.*

1. Install battery terminal cap(s) onto battery cable(s) as follows:
  - A. ORANGE battery terminal cap onto RED battery cable extending from box top.
  - B. GRAY battery terminal cap onto BLACK battery cable extending from box top.
  - C. ORANGE battery terminal cap onto BLACK or WHITE battery (jumper) cable.
  - D. GRAY battery terminal cap onto BLACK or WHITE battery (jumper) cable.

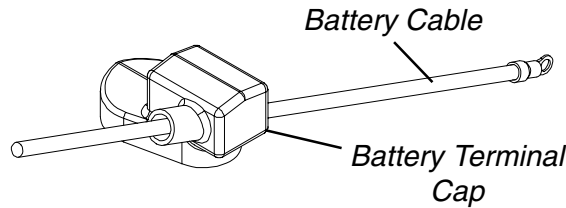

FIGURE 6 - INSTALLING TERMINAL CAPS

**SECTION F - CONNECTING BATTERY CABLE(S) TO BATTERY(IES) (FIGURE 7)**

1. Connect battery cable(s) to battery(ies) terminal(s)/post(s) as shown in FIGURE 9.

**CAUTION**

When connecting the battery cables to the battery(ies), the battery cable(s) **MUST** be connected to the battery terminal(s)/post(s) as shown in FIGURE 7 (below), otherwise damage to the battery cable(s) may result when sliding battery terminal cap(s) down onto battery terminal/posts.

When tightening the clamps, **ALWAYS** use a box wrench. Pliers will "round off" the nuts. **NEVER** wiggle the battery terminal(s)/post(s) when tightening. The battery may become damaged.

The **POSITIVE (+) RED** battery cable **MUST** connect to the **POSITIVE (+)** battery terminal/post, otherwise serious damage will occur to the electrical system.

2. Use one (1) 1/4-20 x 7/8-inch hex flange screw and one (1) 1/4-20 hex flange locknut to secure the battery cables to the battery terminals/posts. Securely tighten. (FIGURE 7)

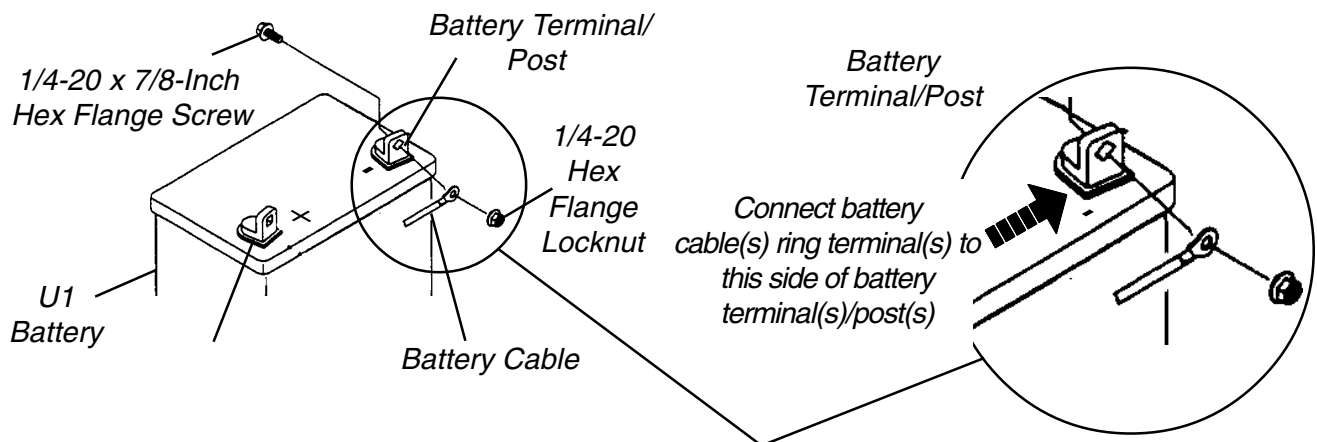

FIGURE 7 - CONNECTING BATTERY CABLE(S) TO BATTERY(IES)

**SECTION F - CONNECTING BATTERY CABLE(S) TO BATTERY(IES)**  
**(continued)**

**WARNING**

NEVER allow any of your tools and/or battery cable(s) to contact BOTH battery terminal(s)/post(s) at the same time. An electrical short may occur and serious personal injury, damage to the wheelchair and/or damage to surrounding property may occur.

3. Connect the battery cable (jumper) terminal end to NEGATIVE (-) battery terminal/post of REAR battery. (DETAIL "F" in FIGURE 8)
4. Connect battery cable (jumper) terminal end to POSITIVE (+) battery terminal/post of FRONT battery. (DETAIL "F" in FIGURE 8)
5. Connect NEGATIVE (-) BLACK battery cable from box top to NEGATIVE (-) battery terminal/post of FRONT battery. (DETAIL "G" in FIGURE 8)
6. Connect POSITIVE (+) RED battery cable extending from box top to POSITIVE (+) battery terminal/post of REAR battery. (DETAIL "G" in FIGURE 8)

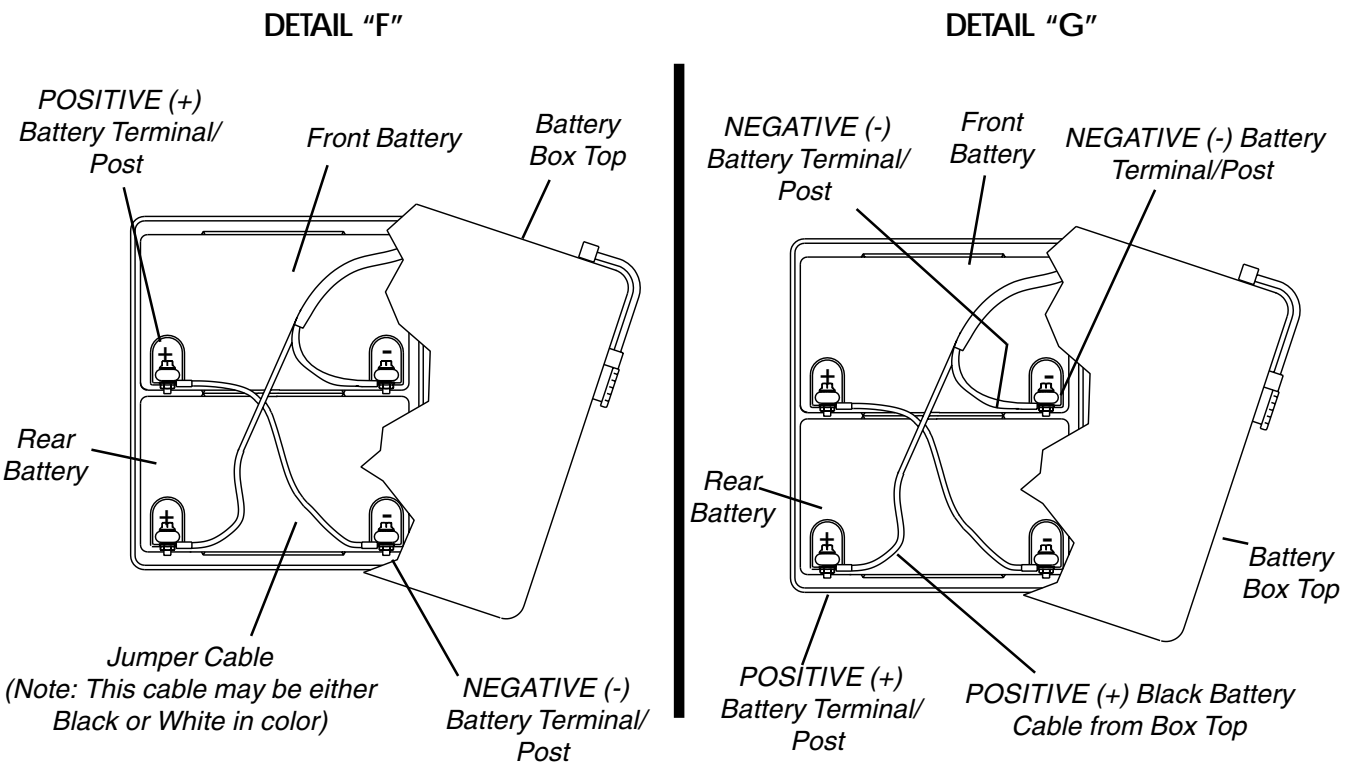

**FIGURE 8 - CONNECTING BATTERY CABLE(S) TO BATTERY(IES)**

BATTERIES

**SECTION G - SECURING TERMINAL CAPS TO BATTERY TERMINALS/POSTS (FIGURE 9)**

1. Verify battery cable(s)/ring terminal(s) are correctly installed and securely tightened.
2. Slide terminal cap(s) down battery cable(s) and onto battery terminal(s)/post(s).
3. Secure each terminal cap in place with a tie-wrap (Use tie-wraps 11-1/2-inches long).

*NOTE: It will be necessary to trim excess tie-wrap in order to install the battery box top(s).*

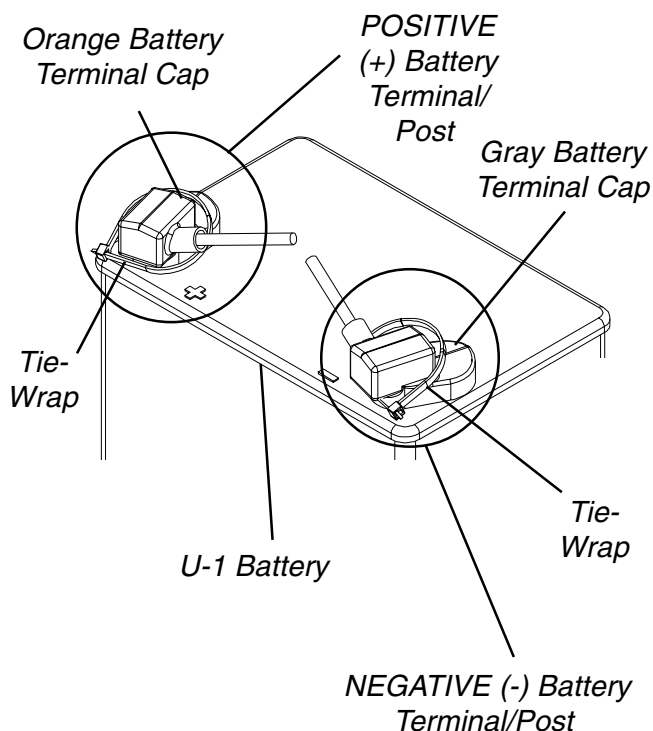

**FIGURE 9 - SECURING TERMINAL CAPS TO BATTERY TERMINALS/POSTS**

**SECTION H - INSTALLING BATTERY BOX INTO WHEELCHAIR (FIGURE 10)**

1. Verify that the ON/OFF switch on the joystick is in the OFF position.
2. Position the battery box(es) onto the battery tray. Make sure the battery cables on the battery box(es) are on the same side as the battery connectors on the wheelchair frame.
3. Connect the battery box(es) retaining strap clip together.
4. Connect the battery cables from the battery box(es) to the battery connectors on the wheelchair frame.

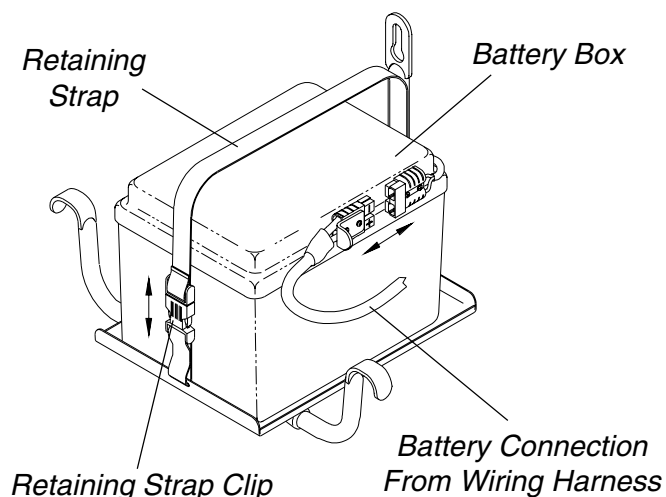

**FIGURE 10 - INSTALLING SINGLE BATTERY BOX INTO WHEELCHAIR**

**SUMMARY OF INSTALLATION FOR - OPTIONAL DUAL BATTERY BOX**

1. Perform the sections indicated, in order, to properly remove and/or install the batteries:

**Initial Installation of Batteries into Battery Box**

- A. Remove dual battery boxes from wheelchair.
- B. N/A
- C. Installing battery into dual battery box
- D. N/A
- E. Install Terminal Caps
- F. Connect Battery Cables.
- G. Secure terminal caps to battery terminals/ posts.
- H. Install battery box into wheelchair.

**Removing/Installing the Batteries into/from Battery Box**

- A. Remove dual battery box from wheelchair.
- D. Disconnecting Battery Cables.
- B. Remove the batteries from the dual battery boxes
- C. Install the batteries into the dual battery boxes.
- F. Connecting Battery Cables.
- G. Securing terminal caps to battery terminals/ posts.
- H. Install dual battery box into wheelchair.

**SECTION A - REMOVE DUAL BATTERY BATTERY BOXES FROM WHEELCHAIR (FIGURE 1)**

1. Place wheelchair in a well ventilated area where work can be performed without risking damage to carpeting or floor covering.
2. Verify that the ON/OFF switch on the joystick is in the OFF position.
3. Disconnect the battery cables of the dual battery boxes from the battery connectors on the wheelchair frame.
4. Disconnect the battery box retaining strap clip.
5. Remove batteries from wheelchair.

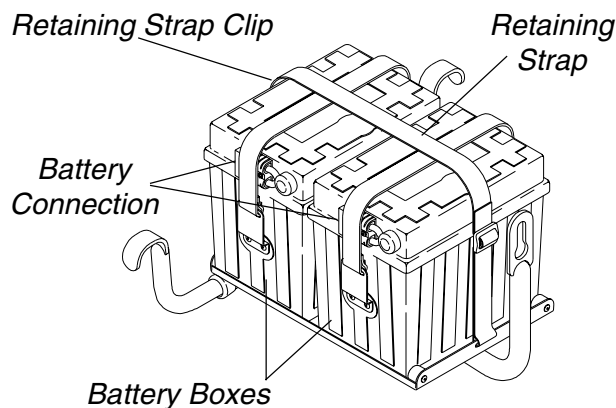

NOTE: Wheelchair Frame not shown for clarity.

**FIGURE 1 - REMOVING BATTERIES FROM BATTERY BOX**

**SECTION B - REMOVING THE BATTERIES FROM THE DUAL BATTERY BOXES (FIGURE 2)**

**WARNING**

Always use a battery lifting strap when lifting a battery. It is the most convenient method and assures that the battery acid will not spill (wet cell batteries). It also helps to prolong the life of the battery.

NOTE: Refer to the battery manufacturer for the proper lifting strap and/or battery tools for U1 battery removal/installation.

1. Clean battery terminals. Refer to CLEANING BATTERY TERMINALS in this section.
2. Secure battery lifting strap or battery tools to battery and remove from battery box. Repeat for other battery.

NOTE: If there is battery acid in the bottom or on the sides of the battery box or battery, apply baking soda to these areas to neutralize the battery acid. Before reinstalling the NEW or existing battery(ies), clean the baking soda from the battery box(es) or battery(ies).

**Cleaning Battery Terminals**

**WARNING**

Most batteries are not sold with instructions. However, warnings are frequently noted on the cell caps. Read them carefully.

DO NOT allow the liquid in the battery to come in contact with skin, clothes or other possessions. It is a form of acid and harmful or damaging burns may result. Should the liquid touch your skin, wash the area immediately and thoroughly with cool water. In serious cases or if eye contact is made, seek medical attention IMMEDIATELY.

NEVER smoke or strike a match near the batteries. If the caps of the battery cells are removed, NEVER look directly into them when charging the battery.

1. Examine the battery clamps and terminals for corrosion.
2. Verify that the plastic caps are in place over the battery cell holes.
3. Clean the terminals and inside the battery clamps by using a battery cleaning tool, wire brush, or medium grade sand paper.

*NOTE: Upon completion, these areas should be shiny, not dull.*

4. Carefully dust off all metal particles.

**SECTION C - INSTALLING THE BATTERIES INTO THE DUAL BATTERY BOXES**

*NOTE: Refer to the battery manufacturer for the proper lifting strap and/or battery tools for U1 battery removal/installation.*

**WARNING**

Always use a battery lifting strap when lifting a battery. It is the most convenient method and assures that the battery acid will not spill (wet cell batteries). It also helps to prolong the life of the battery.

Some battery manufacturers mold a carrying strap and/or hold down flanges directly into the battery case. Batteries which interfere with the battery box cannot be used for these applications. Attempting to "wedge" a battery into a battery box may damage the box and/or the battery. Refer to DETAIL "A" in FIGURE 2.

1. Secure battery lifting strap or battery tools to battery and place battery in dual battery box.

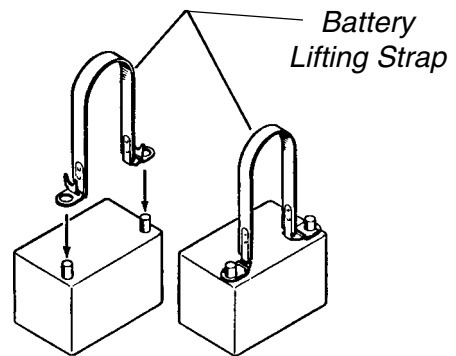
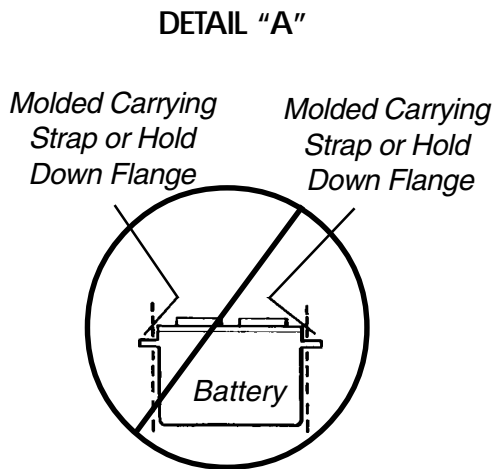

Molded Carrying Strap or Hold Down Flanges

U1 Battery Box Bottom

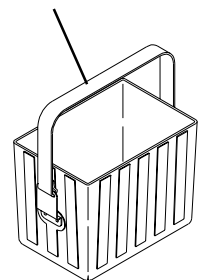
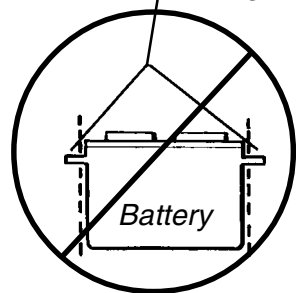

FIGURE 2 - REMOVING/INSTALLING THE BATTERIES FROM/INTO BATTERY BOX

**SECTION D - DISCONNECT BATTERY CABLE(S) FROM BATTERY(IES)**

**WARNING**

NEVER allow any of your tools and/or battery cable(s) to contact BOTH battery terminal(s)/post(s) at the same time. An electrical short may occur and serious personal injury, damage to the wheelchair and/or damage to surrounding property may occur.

1. Carefully lift up existing U1 battery box top to expose the underlying battery cables.
2. Cut the tie-wraps that secure the orange and gray caps to the battery terminals/posts. (DETAIL "B" in FIGURE 3)
3. Slide the terminal caps up on the battery cable. (DETAIL "C" in FIGURE 3)

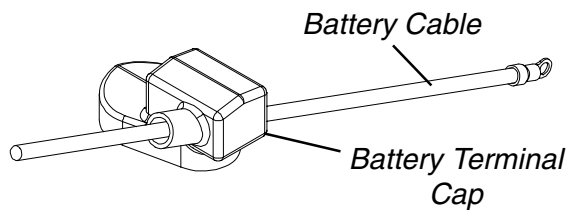
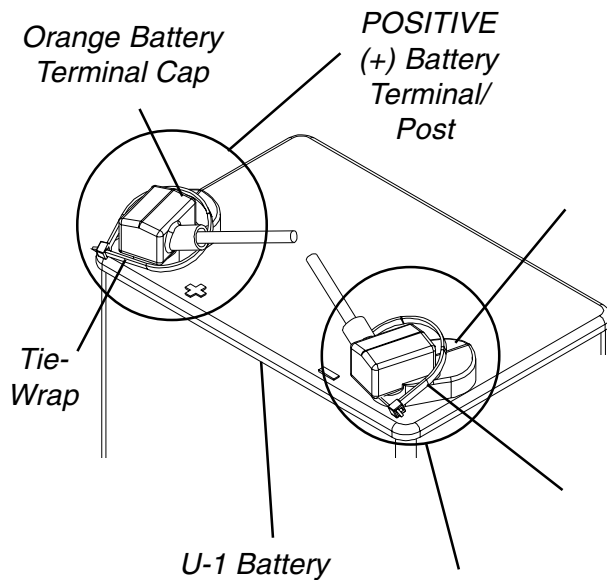

**FIGURE 3 - REMOVING/INSTALLING THE BATTERIES FROM/INTO DUAL BATTERY BOXES**

4. Disconnect battery cable(s) from the battery as follows:
  - A. Remove the hex screw and locknut that secures the NEGATIVE (-) BLACK battery cable to NEGATIVE (-) battery terminal/post.
  - B. Remove the hex screw and locknut that secures the POSITIVE (+) RED battery cable to POSITIVE (+) battery terminal/post.
5. Secure battery lifting strap and/or battery tools to battery terminal(s)/post(s).
6. Remove the battery from the battery box bottom.

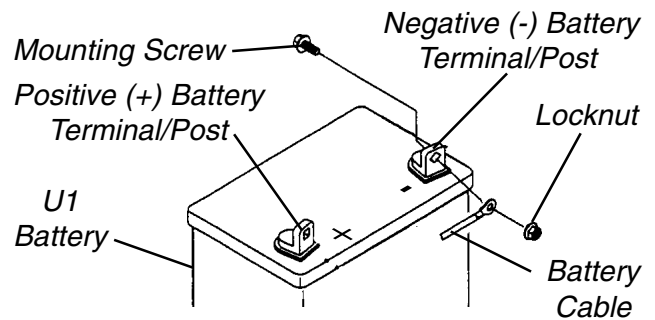

**FIGURE 4 - REMOVING BATTERY FROM DUAL BATTERY BOXES**

**SECTION E - INSTALLING TERMINAL CAPS (FIGURE 8)**

*NOTE: Refer to INSTALLATION WARNINGS and CAUTIONS in the SAFETY SUMMARY of this instruction sheet.*

1. Install battery terminal cap(s) onto battery cable(s) as follows:
  - A. ORANGE battery terminal cap onto RED battery cable extending from box top.
  - B. GRAY battery terminal cap onto BLACK battery cable extending from box top.
  - C. ORANGE battery terminal cap onto BLACK or WHITE battery (jumper) cable.
  - D. GRAY battery terminal cap onto BLACK or WHITE battery (jumper) cable.

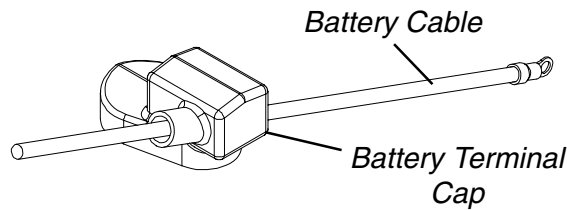

FIGURE 8 - INSTALLING TERMINAL CAPS

**SECTION F - CONNECTING BATTERY CABLE(S) TO BATTERY(IES) (FIGURE 9)**

1. Connect battery cable(s) to battery(ies) terminal(s)/post(s) as shown in FIGURE 9.

**CAUTION**

When connecting the battery cables to the battery(ies), the battery cable(s) **MUST** be connected to the battery terminal(s)/post(s) as shown in FIGURE 9 (below), otherwise damage to the battery cable(s) may result when sliding battery terminal cap(s) down onto battery terminal/posts.

When tightening the clamps, **ALWAYS** use a box wrench. Pliers will “round off” the nuts. **NEVER** wiggle the battery terminal(s)/post(s) when tightening. The battery may become damaged.

The **POSITIVE (+) RED** battery cable **MUST** connect to the **POSITIVE (+)** battery terminal/post, otherwise serious damage will occur to the electrical system.

2. Use one (1) 1/4-20 x 7/8-inch hex flange screw and one (1) 1/4-20 hex flange locknut to secure the battery cables to the battery terminals/posts. Securely tighten. (FIGURE 7)

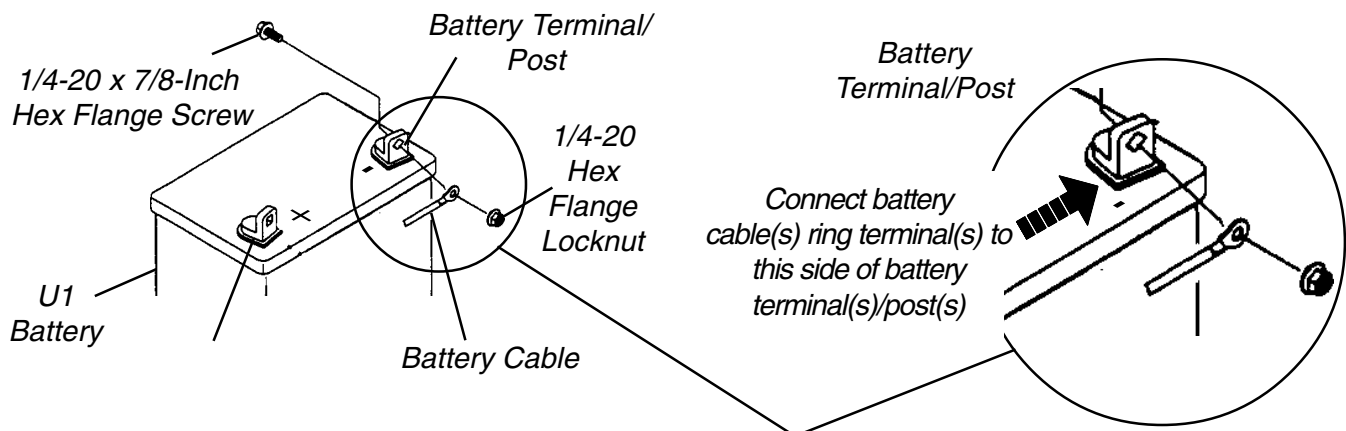

FIGURE 9 - CONNECTING BATTERY CABLE(S) TO BATTERY(IES)



**SECTION G - SECURING TERMINAL CAPS TO BATTERY TERMINALS/POSTS (FIGURE 14)**

1. Verify battery cable(s)/ring terminal(s) are correctly installed and securely tightened.
2. Slide terminal cap(s) down battery cable(s) and onto battery terminal(s)/post(s).
3. Secure each terminal cap in place with a tie-wrap (Use tie-wraps 11-1/2-inches long).

*NOTE: It will be necessary to trim excess tie-wrap in order to install the battery box top(s).*

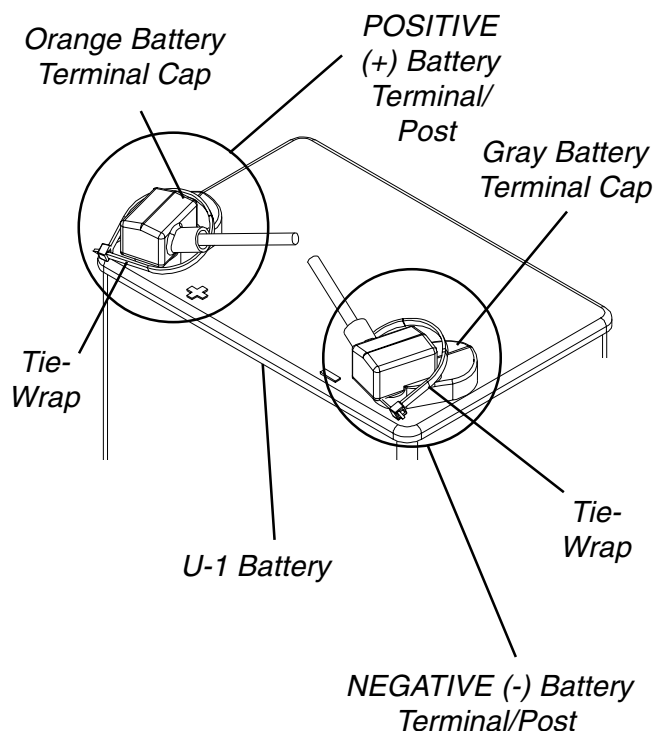

**FIGURE 14 - SECURING TERMINAL CAPS TO BATTERY TERMINALS/POSTS**

**SECTION H - INSTALLING BATTERY BOX INTO WHEELCHAIR (FIGURE 15)**

1. Verify that the ON/OFF switch on the joystick is in the OFF position.
2. Position the battery box(es) onto the battery tray. Make sure the battery cables on the battery box(es) are on the same side as the battery connectors on the wheelchair frame.
3. Connect the battery box(es) retaining strap clip together.
4. Connect the battery cables from the battery box(es) to the battery connectors on the wheelchair frame.

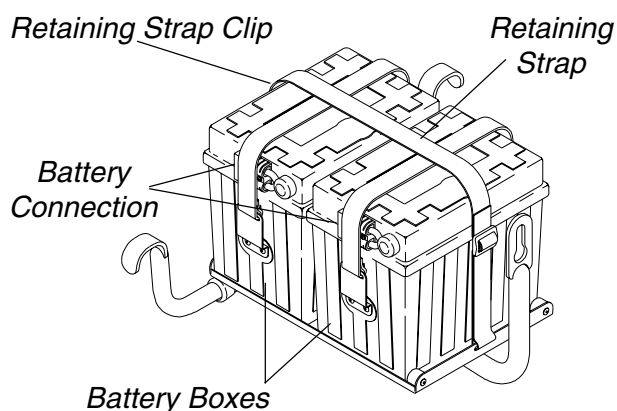

*NOTE: Wheelchair Frame not shown for clarity.*

**FIGURE 15 - INSTALLING/REMOVING BATTERY BOX(ES)**

**WHEN TO CHARGE BATTERIES  
(FIGURE 5)**

It is advantageous to recharge frequently rather than only when necessary. In fact, a battery's life is extended if the charge level is maintained well above a low condition.

**MKIV-R11 Joystick**

**BATTERY GAUGE DISPLAY (BGD)** - Located at the front of the joystick housing provides information on the remaining charge in the batteries. At full charge the BGD will be Green. As the battery becomes discharged, the BGD will become Yellow (Amber), then Red and finally the BGD will flash ON and OFF Red. At this level, the user should charge the batteries as soon as possible.

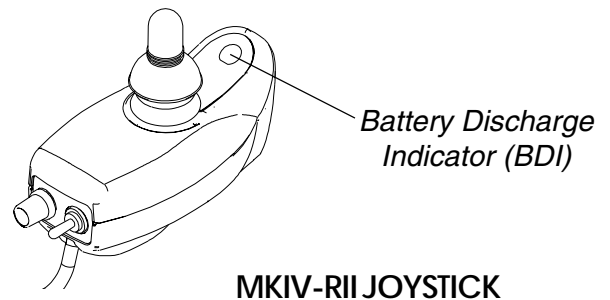

FIGURE 5 - WHEN TO CHARGE BATTERIES

**CHARGING THE BATTERIES  
(FIGURE 6)**

*NOTE: New batteries MUST be fully charged prior to initial use of the wheelchair.*

<b>WARNING</b>
<p>Always charge new batteries before initial use or battery life will be reduced.</p> <p>As a general rule, you should recharge your batteries as frequently as possible to assure the longest possible life and to minimize the required charging time. Plan to recharge them when you do not anticipate using the wheelchair for a long period of time.</p> <p>Never attempt to recharge the batteries by attaching cables directly to the battery terminals or clamps. Use the recharging plug located on either the side of the wheelchair frame or on the front of the joystick.</p> <p><b>DO NOT</b> attempt to recharge the batteries and operate the power wheelchair at the same time.</p>

The range per battery charge using recommended batteries should be approximately 5 to 9 hours of typical operation. Extensive use on inclines may substantially reduce per charge mileage.

**Description and Use of Battery Charger - Standard 4 AMP Battery Charger**

The charger automatically reduces the charge from an initially high rate to a zero reading at a fully charged condition.

*NOTE: The Charger output and green light will stay ON until the power switch on the battery charger is moved to the OFF position.*

**There are some basic concepts which will help you understand this automatic process:**

The amount of electrical current drawn within a given time to charge a battery is called "charge rate". If, due to usage, the charge stored in the battery is low, the charge rate is high. As a charge builds up, the charge rate is reduced and the battery charger rate decreases to a "trickle charge".

*NOTE: If performing the charging procedures independently, READ and CAREFULLY follow the individual instructions for each charger (supplied or purchased).*

*NOTE: If charging instructions are not supplied, consult a qualified service technician for proper procedures.*

**Required Items:**

TOOL	QUANTITY	COMMENTS
Battery Charger	1	Supplied
⊗Extension Cord	1	Not Supplied
⊗(3-prong plug, 15 ampere current rating; industrial type)		

**WHEELCHAIRS EQUIPPED WITH MCC-MARK IV JOYSTICK (DETAIL "A" OF FIGURE 6)**

1. Attach the battery charger connector to the charger cable/battery harness.
2. Plug the charger's AC power cord, or extension, into the grounded 120 VAC wall outlet.
3. Move the power switch on the battery charger to the ON position.
4. Wait until charging is complete.

*NOTE: Allow eight (8) hours for normal charging. Severely discharged batteries may require up to sixteen (16) hours to be properly charged and equalized.*

*NOTE: The Charger output and green light will stay ON until the power switch on the battery charger is moved to the OFF position.*

**Wheelchairs Equipped With Mark IV RII Joystick (Detail "B" of FIGURE 6)**

1. Attach the battery charger connector to the charger port on the FRONT of the joystick.
2. Plug the charger's AC power cord, or extension, into the grounded 120 VAC wall outlet.
3. Wait until charging is complete.

*NOTE: Allow eight (8) hours for normal charging. Larger batteries (greater than 55 ampere-hours) or severely discharged batteries may require up to sixteen (16) hours to be properly charged and equalized. If the charger operates for sixteen (16) hours and is unable to fully charge the batteries, an internal timer turns the charger off and begins to fast blink the green light.*

*NOTE: If the batteries need to be charged more often or take longer to charge than normal, they may need to be replaced. Contact an Invacare dealer for service.*

DETAIL "A"

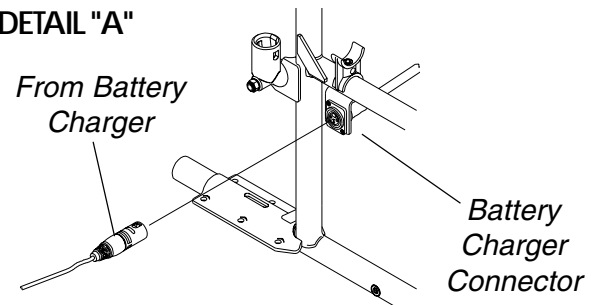

DETAIL "B"

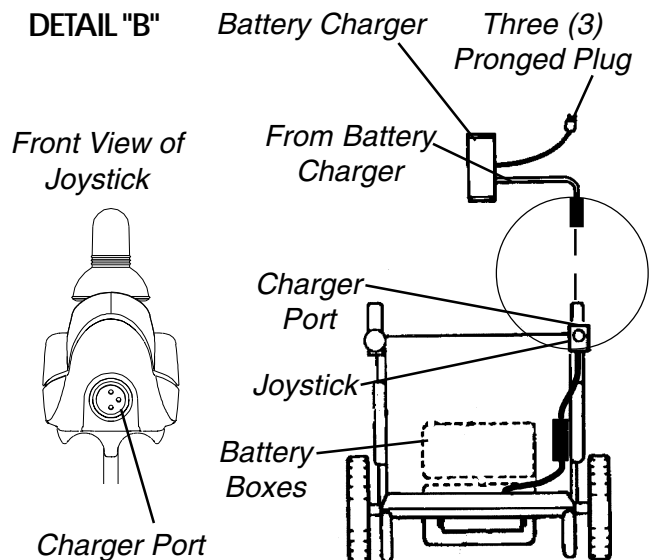

FIGURE 6 - CHARGING THE BATTERIES

<p><i>This Procedure includes the following:</i></p> <p><b>Preparing the MKIV-RII Joystick for Use</b></p> <p><b>Disconnecting/Connecting the MKIV-RII-LP Controller Motor and Battery Leads</b></p> <p><b>Repositioning the MKIV-RII Joystick</b></p> <p><b>Removing/Installing the MKIV-RII-LP Controller</b></p>
---

**PREPARING THE MKIV-RII JOYSTICK FOR USE (FIGURE 1)**

*NOTE: The MKIV-RII joystick is factory installed on the right side of the wheelchair. To reposition the MKIV-RII joystick onto the left side of the wheelchair, refer to REPOSITIONING THE MKIV-RII JOYSTICK in this section of the manual.*

1. Turn the lever on the adjustment lock to release the adjustment lock from joystick mounting tube.
2. Remove the joystick mounting tube from the adjustment lock.
3. Reposition the joystick mounting tube so that the joystick is facing towards the front of the wheelchair.
4. Slide the joystick mounting tube to the desired position.
5. Turn the lever on the adjustment lock to secure the adjustment lock to the joystick mounting tube.

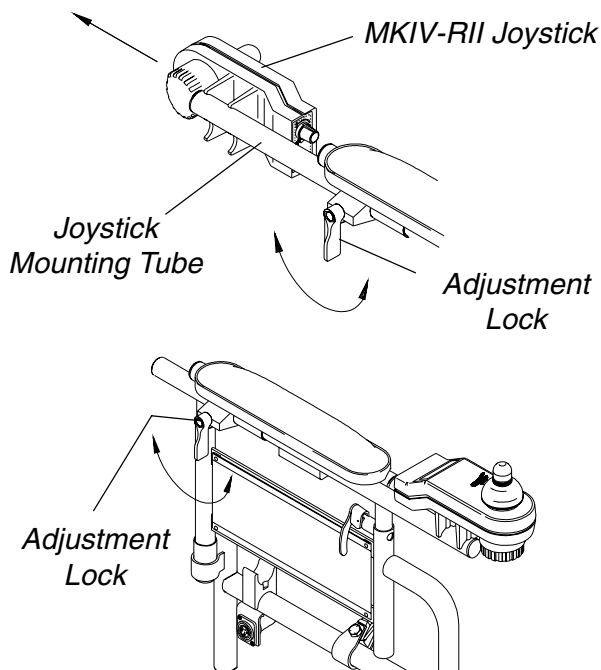
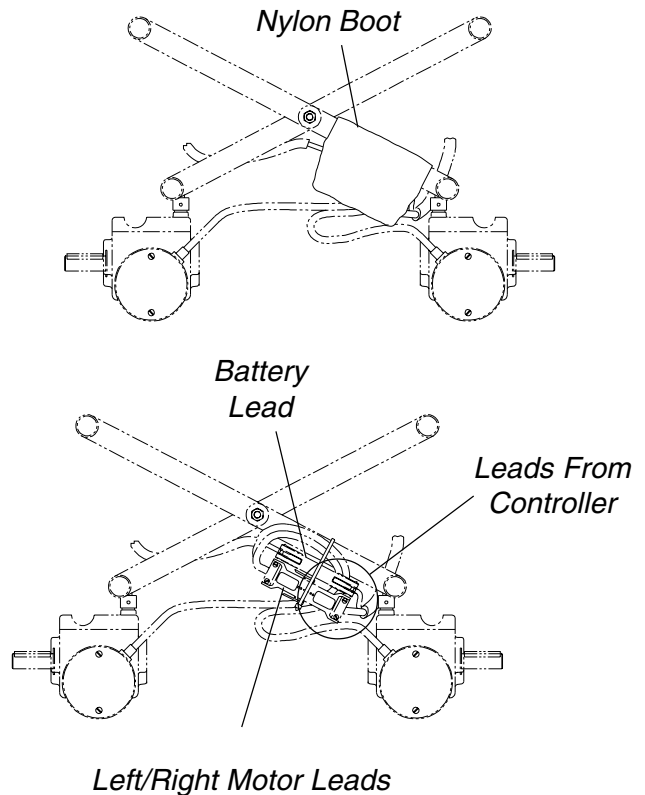

**FIGURE 1 - PREPARING THE MKIV-RII JOYSTICK FOR USE**

**DISCONNECTING/CONNECTING THE MKIV-RII-LP CONTROLLER MOTOR AND BATTERY LEADS (FIGURE 2)**

*NOTE: To connect MKIV-RII-LP controller motor and battery leads, reverse the following procedure.*

1. Disconnect the fastening straps that secure the nylon boot around the connected motor and battery leads.
2. Disconnect the controller left/right motor and battery leads from the leads secured to the wheelchair with tie wrap.



**FIGURE 2 - DISCONNECTING/CONNECTING THE MKIV-RII-LP CONTROLLER MOTOR AND BATTERY LEADS**

## REPOSITIONING THE MKIV-RII JOYSTICK (FIGURE 3)

1. Turn the lever on the adjustment lock to release the adjustment lock from joystick mounting tube (tube).
2. Remove the joystick from the wheelchair.
3. Remove the three (3) hex screws that secure the joystick mounting bracket (bracket), the threaded hole half clamp and the opened hole half clamp to the arm tube.
4. Reposition the threaded hole half clamp and opened hole half clamp on the opposite arm tube. Make sure the threaded hole half clamp is on the inside of the arm tube.
5. While holding the two (2) half clamps, install the front hex screw into the two (2) half clamps and securely tighten.
6. Line up the mounting holes of the joystick mounting bracket with the mounting holes in the two (2) half clamps.
7. Secure the joystick mounting bracket to the two (2) half clamps with the remaining two (2) hex screws.

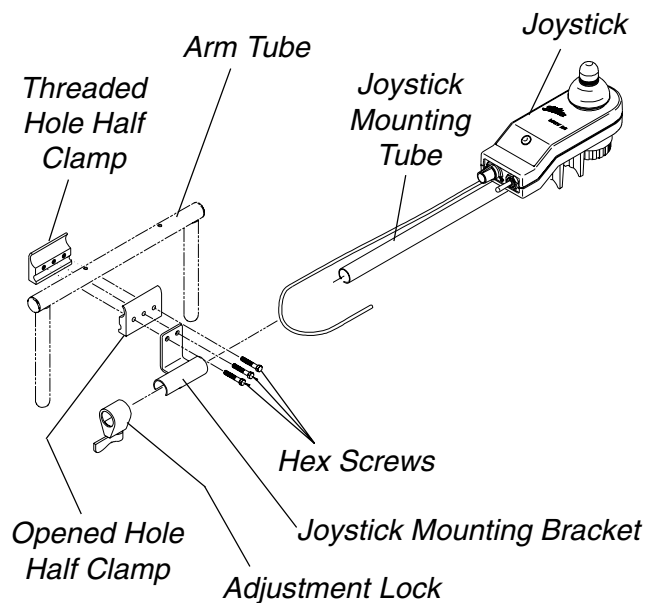

FIGURE 3 - INSTALLING THE MKIV-RII JOYSTICK

8. Slide the tube through the bracket to the desired position.
9. Slide the adjustment lock over the end of the tube and secure the adjustment lock to the tube by turning the lever on the adjustment lock.

## REMOVING/INSTALLING MKIV-RII-LP CONTROLLER (FIGURE 4)

1. Disconnect the left/right motor leads and battery leads. Refer to DISCONNECTING/CONNECTING THE MKIV-RII-LP CONTROLLER MOTOR AND BATTERY LEADS in this section of the manual.
2. Remove the three (3) Shoulder Bolts, four (4) washers, two (2) clamps, three (3) spacers and two (2) locknuts that secure the MKIV-RII controller onto the wheelchair.

*NOTE: When installing the MKIV-RII-LP controller onto the wheelchair, use Loctite 242 on hex screws.*

3. Install the MKIV-RII-LP controller onto the wheelchair by reversing STEPS 1 and 2.

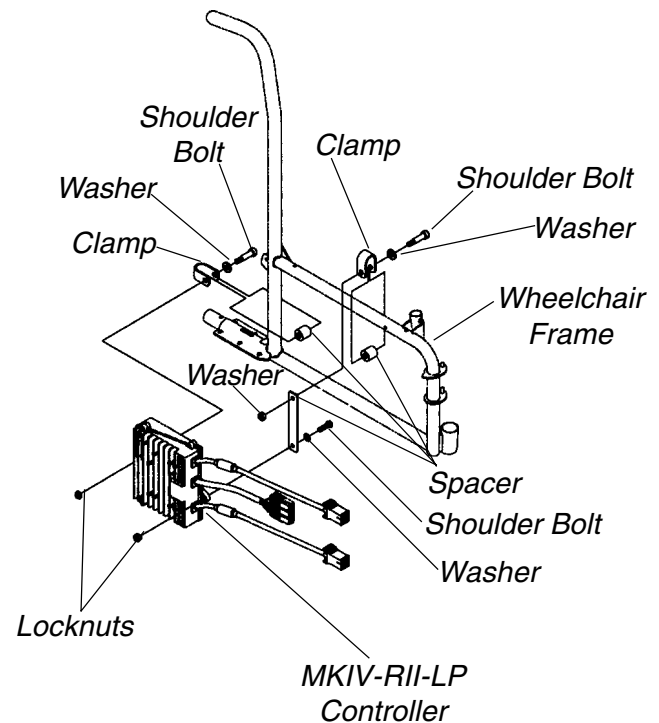

FIGURE 4 - REMOVING/INSTALLING MKIV-RII-LP CONTROLLER

*This Procedure includes the following:*  
**Replacing Battery Box Retaining Strap**

**REPLACING BATTERY BOX RETAINING STRAP (FIGURE 1)**

1. Remove the battery box(es). Refer to INSTALLING/REMOVING THE BATTERY BOX(ES) in PROCEDURE 6 of this manual.

**WARNING**  
 The retaining strap **MUST** be fed through the adjustable end of the battery box retaining strap clip as shown in FIGURE 1.

2. Feed the existing battery box retaining strap through the battery box retaining strap buckle.
3. Feed the existing battery box retaining strap through the slot in the battery box tray.

4. Feed the new battery box retaining strap through the inside of the slot in the battery box tray.
5. Feed the new battery box retaining strap through the adjustable end of the battery box retaining strap buckle.
6. Reinstall the battery box(es). Refer to INSTALLING/REMOVING THE BATTERY BOX(ES) in PROCEDURE 6 of this manual.

**WARNING**  
 The Battery Box Retaining Strap **MUST** be fastened securely in place before using the wheelchair.

*NOTE: The retaining strap should fit snug over the battery box(es) when properly adjusted.*

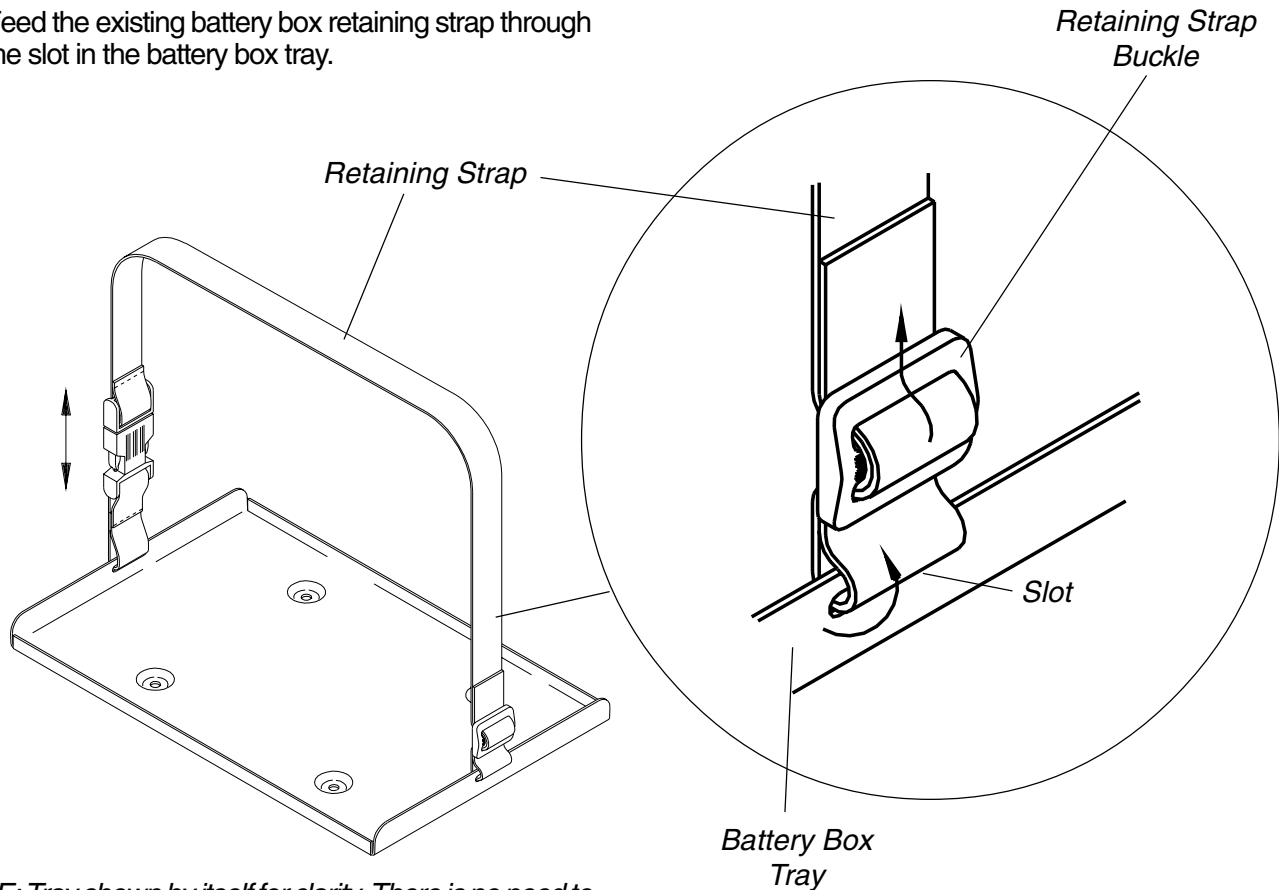

*NOTE: Tray shown by itself for clarity. There is no need to remove the tray from the wheelchair if the retaining strap is being replaced.*

**FIGURE 1 - REPLACING BATTERY BOX RETAINING STRAP**

**This Procedure includes the following:**  
**Replacing the Wiring Harness**

**REPLACING THE WIRING HARNESS (FIGURE 1)**

**WARNING**  
 The following procedure should be performed only by an Invacare dealer or qualified technician.

**Disassembly**

1. Remove the battery box(es). Refer to INSTALLING/REMOVING THE BATTERY BOX(ES) in PROCEDURE 6 of this manual.
2. **Disconnect the following cables:**
  - a. The right and left motor connectors from the controller connectors.
  - b. The wiring harness (BLUE) from the controller connector (BLUE).
3. Remove the two (2) phillips screws and locknuts that secure the charger cable to the charger cable mounting bracket.

4. Cut the tie wraps that secure the wiring harness to the wheelchair frame and crossbrace.
5. Remove the wiring harness from the wheelchair.

**Reassembly**

1. Secure the charger cable to existing mounting bracket on the seat frame with the two (2) phillips screws and locknuts.
2. **Connect the following cables:**
  - a. The right and left motor connectors to the controller connectors.
  - b. The wiring harness (BLUE) to the controller connector (BLUE).

3. Re-secure the wiring harness to the wheelchair and crossbraces with new tie wraps.

*NOTE: Tighten the tie wrap that secures the wiring harness to the crossbrace until there is approximately 5-1/2-inches of tie wrap threaded through the clamp on the tie wrap.*

4. Reinstall the battery box(es). Refer to INSTALLING/REMOVING BATTERY BOX(ES) in PROCEDURE 6 of this manual.

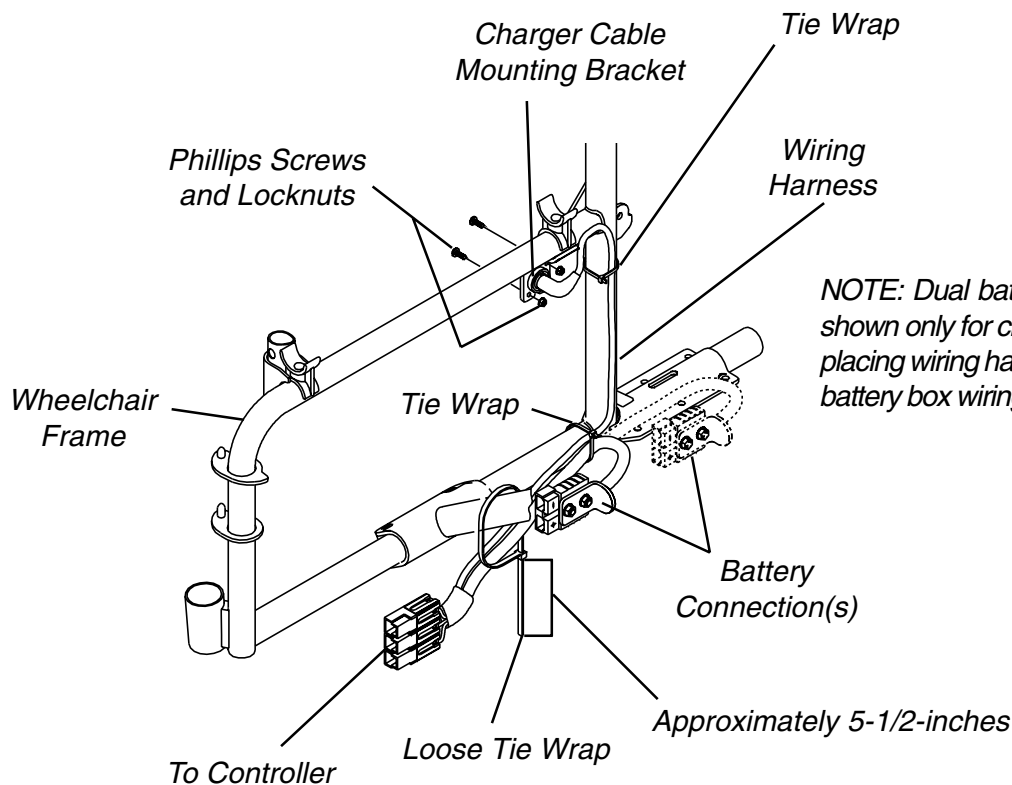

FIGURE 1 - REPLACING THE WIRE HARNESS

**This Procedure includes the following:**

- Engaging/Disengaging Clutches
- Using/Installing/Adjusting Wheel Locks
- Replacing Pneumatic Tires and Tubes - Front Casters and Rear Wheels
- Installing/Replacing Rear Wheel Assemblies
- Installing/Replacing Front Caster Assemblies
- Replacing Front Fork
- Installing the Anti-Tippers
- Installing Optional Clutch Extension Handles

**CAUTION**

As with any vehicle, the wheels and tires should be checked periodically for cracks and wear and should be replaced when necessary.

**ENGAGING/DISENGAGING CLUTCHES (FIGURES 1 AND 2)**

**WARNING**

DO NOT engage or disengage the clutches until the power is in the OFF position.

The clutch engagement/disengagement allows freewheeling or joystick controlled operation. Freewheeling allows an attendant to maneuver the wheelchair without power. To engage/disengage the clutches:

BATTERY BOX FOR 14-INCH WIDE WHEELCHAIRS

BATTERY BOX FOR 16-20-INCH WIDE WHEELCHAIRS

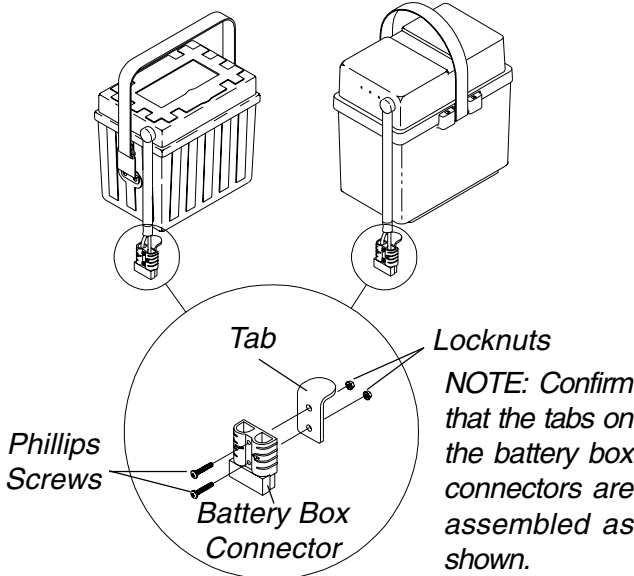

FIGURE 1 - BATTERY BOX CONNECTOR TABS

NOTE: If the wheelchair is equipped with clutch extension handles, refer to STEP 1 below. If the wheelchair is not equipped with clutch extension handles, proceed to STEP 2.

**WARNING**

The tabs on the battery box connectors MUST be assembled as shown in FIGURE 2. Otherwise the connectors will not engage completely and clutch handles could disengage connectors.

1. Confirm that the tabs on the battery box connectors are assembled as shown in FIGURE 1.

NOTE: If the tab on the battery box connectors is not assembled as shown in FIGURE 1, remove the phillips screws and locknuts to assemble the tab onto the connector correctly.

2. Locate the clutch handles on motors (FIGURE 2).

**CAUTION**

If clutch handles are forced to engage in the wrong direction (FIGURE 2), the motors will be damaged and will need to be replaced.

3. Perform one of the following (FIGURE 2):

**TO ENGAGE:** turn the clutch handles until they are pointing towards the rear of the wheelchair. NEVER try to turn the clutch handles towards the FRONT of the wheelchair.

**TO DISENGAGE:** turn the clutch handles until they are pointing towards the rear wheels. NEVER try to turn the clutch handles towards the INSIDE of the wheelchair.

TOP VIEW OF WHEELCHAIR

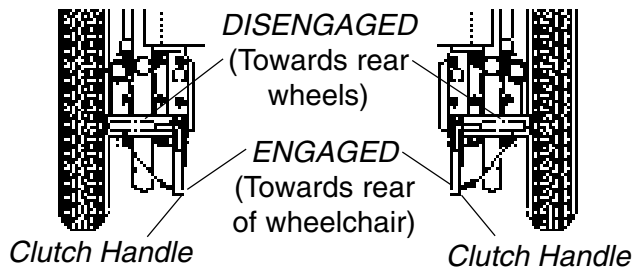

NEVER Force clutch handles in these directions

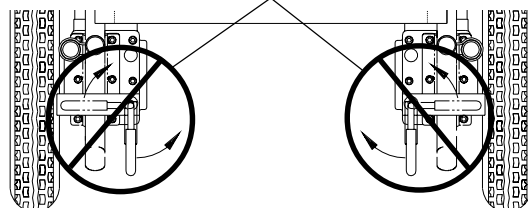

FIGURE 2 - ENGAGING/DISENGAGING CLUTCHES



**USING/INSTALLING/ADJUSTING WHEEL LOCKS\* (FIGURES 3 AND 4)**

**WARNING**

\*Wheel locks are an OPTION on this wheelchair, (you may order with or without wheel locks). Transfer to and from the wheelchair in the presence of a qualified healthcare professional to determine individual safety limits. Invacare strongly recommends ordering the wheel locks as an additional safeguard for the Action wheelchair user.

**Using the Wheel Locks**

The wheelchair is optionally equipped with a pair of independently operated wheel locks located just in front of the rear wheels.

1. To engage the wheel locks, grip the handle and push forward to the lock position.
2. To release, reverse the STEP 1.

*IMPORTANT NOTE: DO NOT use the wheel locks when the wheelchair power is ON and the clutches are engaged.*

*NOTE: Use the wheel locks whenever the clutches are disengaged and the wheelchair is being pushed.*

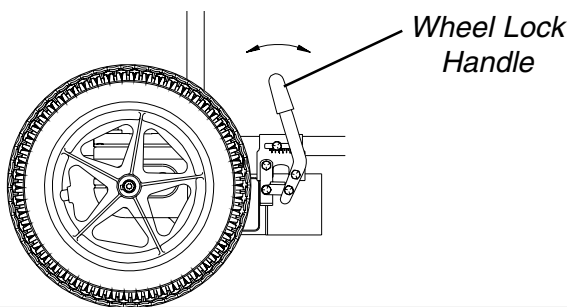

**FIGURE 3 - USING THE WHEEL LOCKS**

**Installing/Adjusting the Wheel Locks**

*NOTE: Before adjusting or replacing the wheel lock assemblies, ensure that the tires are inflated to the recommended psi on the side wall of tire.*

1. Position the wheel lock on the wheelchair frame.
2. Loosely install the hex screw and washer that secures the wheel lock to the wheelchair frame.
3. Make sure the wheel lock is disengaged from the rear wheel.

4. Measure the distance between the **WHEEL LOCK SHOE** and the **REAR WHEEL**.
5. Slide the wheel lock along the wheelchair until the measurement is between 5/32 and 5/16-inches.
6. Tighten the wheel lock to the wheelchair frame with the hex screw and washer.
7. Repeat this procedure for the opposite wheel lock.
8. Disengage the clutches. Refer to **ENGAGING/DISENGAGING CLUTCHES** in this section of the manual.
9. Engage the wheel locks and push against the wheelchair to determine if the wheel locks engage the rear wheels enough to hold the wheelchair.
10. Repeat **STEPS 3-8** until the wheel locks engage the rear wheels enough to hold the wheelchair.
11. Engage the clutches. Refer to **ENGAGING/DISENGAGING CLUTCHES** in this section of the manual.

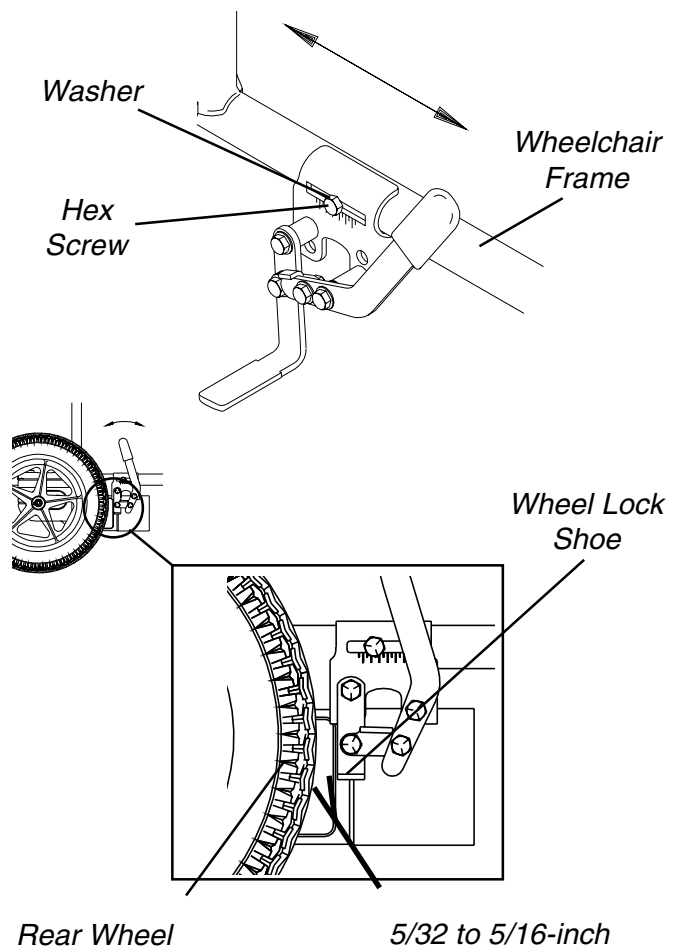

**FIGURE 4 - INSTALLING/ADJUSTING THE WHEEL LOCKS**

**REPLACING PNEUMATIC TIRES AND TUBES - FRONT CASTERS AND REAR WHEELS**

**WARNING**

DO NOT use your power wheelchair unless it has the proper tire pressure (p.s.i.). DO NOT overinflate the tires. Failure to follow these suggestions may cause the tire to explode and cause bodily harm.

If tires are pneumatic, replacement of tire or tube MUST be performed by an Invacare dealer or qualified technician.

NOTE: If front casters or rear wheels are pneumatic, under-inflation causes excessive wear which results in poor performance of the tires.

**INSTALLING/REPLACING REAR WHEEL ASSEMBLIES (FIGURES 5 AND 6)**

**WARNING**

NEVER use a locking tab washer more than once. ALWAYS use a NEW locking tab washer when installing the rear wheels.

1. Remove the hex screw, lockwasher and washer that secure the existing rear wheel assembly to the wheel hub assembly.
2. Use a wheel puller to remove the existing rear wheel assembly from the motor drive shaft.

NOTE: The keystone in the wheel hub MUST lineup with the cutout in the gearbox drive shaft.

3. Install the new/existing rear wheel onto the motor drive shaft. Make sure the chamfered side of the wheel hub is pointing away from the wheelchair.
4. Install washer onto motor drive shaft.
5. Install the NEW locking tab washer onto the motor drive shaft. Make sure the locking tab is in line with the keyway of the rear wheel.
6. Apply Loctite 242 to the hex screw.
7. Install the hex screw. Use a torque wrench only and torque to 90-inch pounds.
8. Examine the head of the hex screw and the locking tab washer. Make sure one (1) of the tabs on the locking tab washer is parallel with one (1) of the flats on the head of the hex screw.

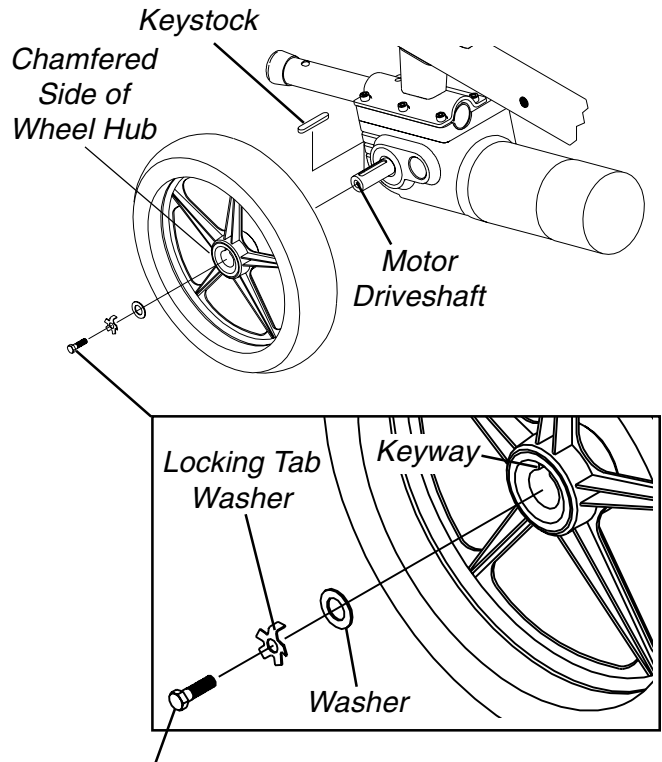

Hex Screw (Apply Loctite 242 and use a Torque Wrench only to Torque to 90-inch pounds)

**FIGURE 5 - INSTALLING/REPLACING REAR WHEEL ASSEMBLIES**

9. If one (1) of the tabs on the locking tab washer is NOT parallel with one (1) of the flats on the head of the hex screw (FIGURE 6), TIGHTEN the hex screw until the closest flat and locking tab are parallel.

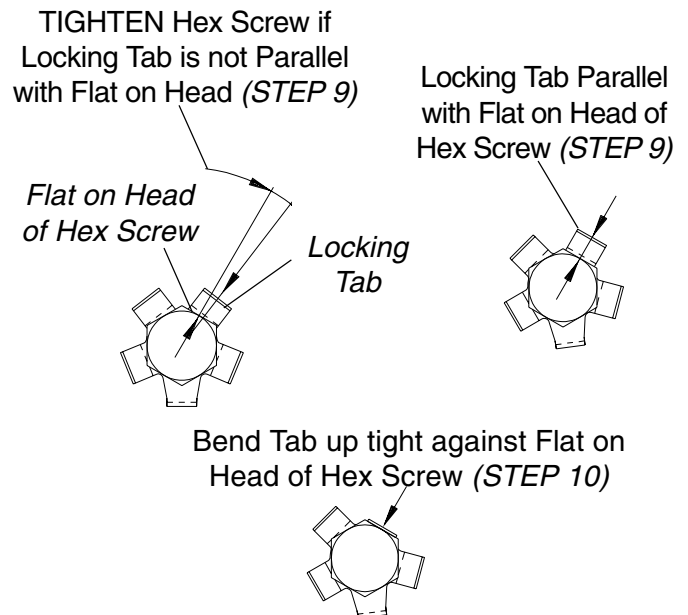

**FIGURE 6 - LOCKING TABS**

### INSTALLING/REPLACING FRONT CASTER ASSEMBLIES (FIGURE 7)

1. Remove the hex screw, spacers and locknut that secure the front caster to the fork.
2. Remove the front caster from the fork.
3. Replace front caster and reverse STEPS 1 and 2.

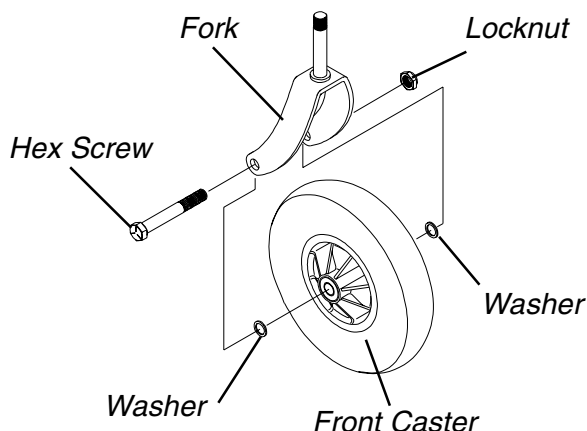

FIGURE 7 - INSTALLING/REPLACING FRONT CASTER ASSEMBLIES

### REPLACING FRONT FORK (FIGURE 8)

1. Remove the front caster assemblies from the wheelchair. Refer to INSTALLING/REPLACING FRONT CASTER ASSEMBLIES in this section of the manual.
2. Remove the head tube cap.
3. Remove the locknut and nylon washer.
4. Drop the fork out of the caster head tube.
5. Slide the new fork into the caster head tube.

*NOTE: Check bearing assemblies and replace if necessary.*

6. Ensure that fork slides completely into the caster head tube.
7. Install nylon washer and secure with locknut.

**WARNING**

Improper positioning of the washer will prohibit the free movement of the forks.

8. Remove the front caster assemblies from the wheelchair. Refer to INSTALLING/REPLACING FRONT CASTER ASSEMBLIES in this section of the manual.
9. To properly tighten caster journal system and guard against flutter, perform the following check:
  - a. Tip front of wheelchair off floor.

- b. Pivot forks and casters to top of their arc simultaneously.
- c. Let casters drop to bottom of arc (wheels should swing once to one-side, then immediately rest in a straight downward position).
- d. Adjust locknuts according to freedom of caster swing.
- e. Test wheelchair for maneuverability.

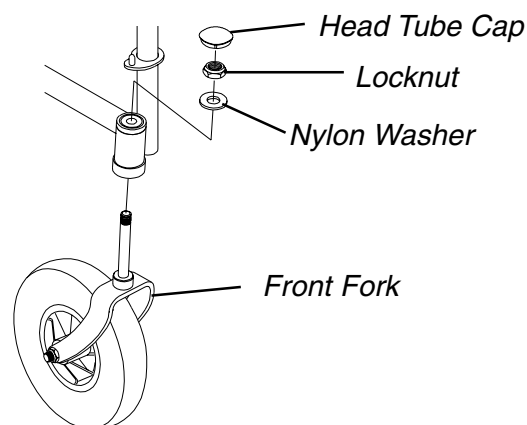

FIGURE 8 - REPLACING FRONT FORK

### INSTALLING/REMOVING THE ANTI-TIPPERS (FIGURE 9)

*NOTE: To remove the anti-tippers from the wheelchair, reverse the following procedures.*

**WARNING**

Anti-tippers **MUST** be attached and pointing **DOWN** towards ground/floor **BEFORE** using the wheelchair.

1. Push the detent pins of the two (2) anti-tippers in and insert anti-tippers into the step tubes of the wheelchair until the anti-tipper wheels are pointing down towards the ground/floor and the anti-tippers are securely locked in place.

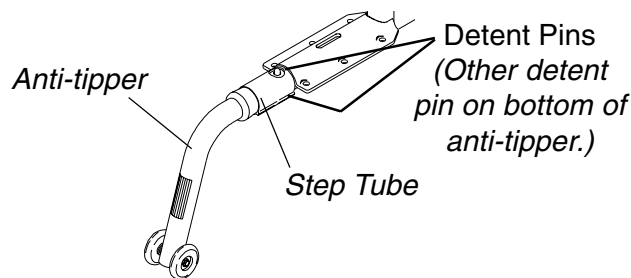

FIGURE 9 - INSTALLING/REMOVING THE ANTI-TIPPERS

WHEELS / ANTI-TIPPER

*NOTE: An audible click will be heard when the anti-tippers are locked in place.*

2. Pull on the anti-tippers to make sure they are locked securely in place before using the wheelchair.

**INSTALLING OPTIONAL CLUTCH EXTENSION HANDLES (FIGURE 10)**

1. Turn the power to the wheelchair to the OFF position.
2. Position the clutch extension handle by the clutch handle on the motor as shown in FIGURE 10.

*NOTE: If the clutch handle on the motor is equipped with a rubber tip, remove the rubber tip before installing the clutch extension handle.*

3. Slide the clutch extension handle onto the clutch handle on the motor.

*NOTE: If necessary, lightly tap the clutch extension handle onto the clutch handle with a plastic mallet. Make sure the vertical portions of both handles are in line.*

4. Securely tighten the set screw on the clutch extension handle.
5. Repeat STEPS 2-4 for the opposite side of the wheelchair.

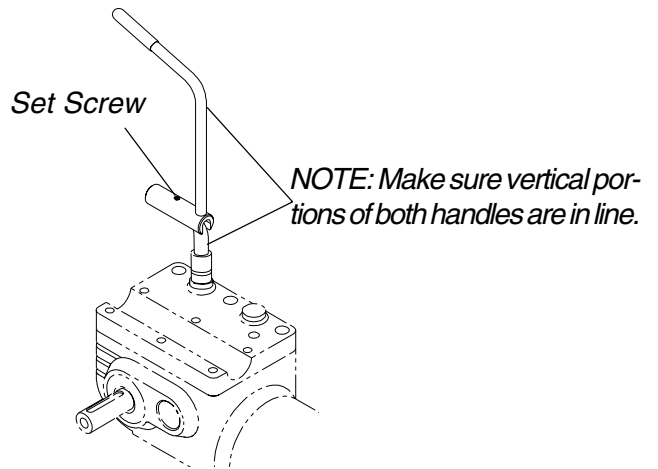
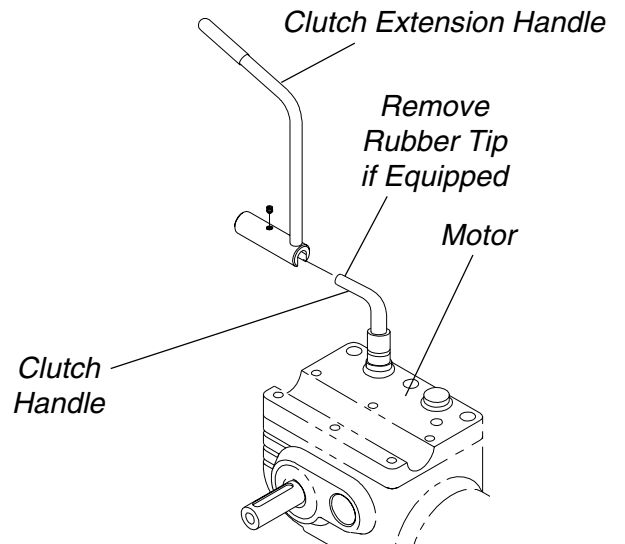

**FIGURE 10 - INSTALLING OPTIONAL CLUTCH EXTENSION HANDLES**

*This Procedure includes the following:*

*Replacing the Motor/Gearbox*

**REPLACING THE MOTOR/  
GEARBOX (FIGURE 1)**

**WARNING**

The following procedure should only be performed by an Invacare dealer or qualified technician.

1. Remove the battery boxes. Refer to INSTALLING/REMOVING BATTERY BOX(ES) in PROCEDURE 6 of this manual.
2. Disconnect the right and/or left motor connector from the controller.
3. Remove the rear wheels from the wheelchair. Refer to INSTALLING/REPLACING REAR WHEEL ASSEMBLIES in PROCEDURE 10 of this manual.
4. Remove the six (6) socket screws that secure the motor/gearbox and support tube to the wheelchair frame.
5. Reposition the new motor/gearbox on the wheelchair frame.

**CAUTION**

The longer socket screws must be positioned in the mounting holes on the OUTSIDE of the wheelchair frame and the short socket screws must be in the mounting holes on the INSIDE of the wheelchair frame. Otherwise damage to the gearbox casting can result.

6. Use Loctite 242 and securely tighten the motor/gearbox to the wheelchair frame with the six (6) socket screws. Torque to 60-inch pounds.
7. Reinstall the rear wheels onto the wheelchair. Refer to INSTALLING/REPLACING REAR WHEEL ASSEMBLIES in PROCEDURE 10 of this manual.
8. Reconnect the right and/or left motor connector to the controller.
9. Repeat procedure for opposite side of the wheelchair, if necessary.
10. Reinstall the battery boxes. Refer to INSTALLING/REMOVING BATTERY BOX(ES) in PROCEDURE 6 of this manual.

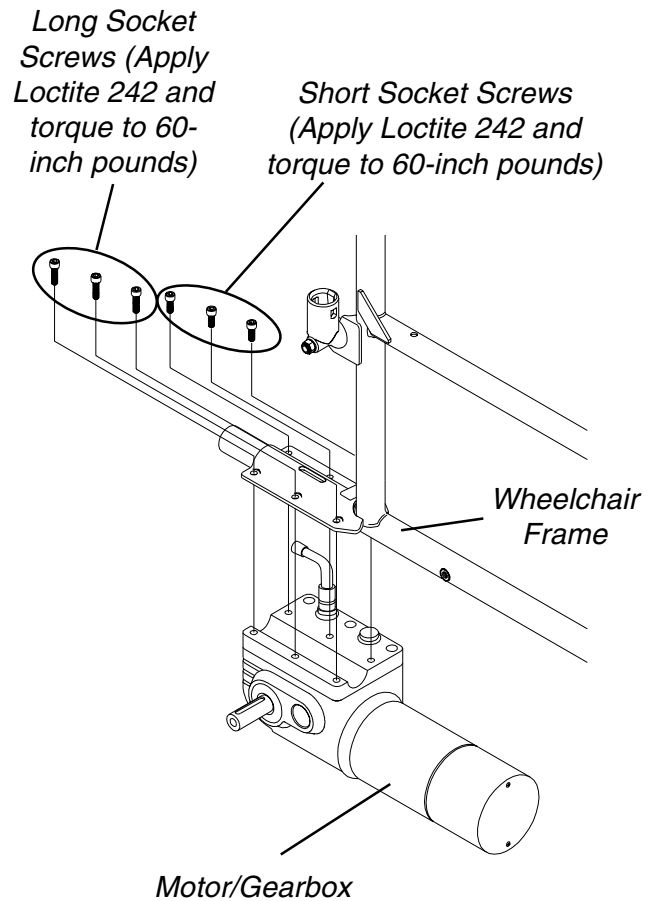

FIGURE 1 - REPLACING THE MOTOR/GEARBOX

MOTOR / GEARBOX

## LIMITED WARRANTY

*PLEASE NOTE: THE WARRANTY BELOW HAS BEEN DRAFTED TO COMPLY WITH FEDERAL LAW APPLICABLE TO PRODUCTS MANUFACTURED AFTER JULY 4, 1975.*

This warranty is extended only to the original purchaser/user of our products.

This warranty gives you specific legal rights and you may also have other legal rights which vary from state to state.

Invacare warrants the side frames and crossbraces to be free from defects in materials and workmanship for a period of two (2) years from date of purchase; electronics, motors and gearboxes for a period of one (1) year from the date of purchase; all remaining components for one (1) year from the date of purchase except upholstered materials, padded materials and tires/wheels. If within such warranty period any product shall be proven to be defective, such product shall be repaired or replaced, at Invacare's option. This warranty does not include any labor or shipping charges incurred in replacement part installation or repair of any such product. Invacare's sole obligation and your exclusive remedy under this warranty shall be limited to such repair and/or replacement.

For warranty service, please contact the dealer from whom you purchased your Invacare product. In the event you do not receive satisfactory warranty service, please write directly to Invacare at the address at the bottom of this page. Provide dealer's name address and the date of purchase, indicate nature of the defect and, if the product is serialized, indicate the serial number. Do not return products to our factory without our prior consent.

**Limitations and Exclusions:** The foregoing warranty shall not apply to serial numbered products if the serial number has been removed or defaced, products subject to negligence, accident, improper operation, maintenance or storage, commercial or institutional use, products modified without Invacare's express written consent (including, but not limited to, modification through the use of unauthorized parts or attachments; products damaged by reason of repairs made to any component without the specific consent of Invacare, or to a product damaged by circumstances beyond Invacare's control, and such evaluation will be solely determined by Invacare. The warranty shall not apply to problems arising from normal wear or failure to adhere to the following instructions.

The foregoing warranty is exclusive and in lieu of all other express warranties. Implied warranties, if any, including the implied warranties of merchantability and fitness for a particular purpose, shall not extend beyond the duration of the expressed warranty provided herein and the remedy for violations of any implied warranty shall be limited to repair or replacement of the defective product pursuant to the terms contained herein. Invacare shall not be liable for any consequential or incidental damages whatsoever.

**THIS WARRANTY SHALL BE EXTENDED TO COMPLY WITH STATE/PROVINCIAL LAWS AND REQUIREMENTS.**

Invacare Corporation

[www.invacare.com](http://www.invacare.com)



**USA**  
One Invacare Way  
Elyria, Ohio USA  
44036-2125  
800-333-6900

**Canada**  
5970 Chedworth Way  
Mississauga, Ontario  
L5R 3T9, Canada  
905-890-8838

Invacare and "Yes, you can" are trademarks of Invacare Corporation.

© 2000 Invacare Corporation  
Form No. 96-120

Part No. 1061807

Rev E (1) - 10/00