

# OWNER'S MANUAL



**Read this manual completely before riding your Electric Tri scooter.**

## TECHNICAL INFORMATION

Product size	: 38 L x 26.8 W x 38.6 H inch (96.5 L x 68 W x 98 H cm)
Type of motor	: permanent-magnet brushed DC motor
Motor power	: 260 w geared motor, 36 V
Battery type	: IBT sealed lead acid battery
Battery	: 10.5AH 36V IBT battery
Charger	: 110V/220V(optional)
Charging time	: 4-6 hours
Rated speed	: 10.5 MPH ( 17 km/h)
Single charge	: 12.4 MILES (20 km)
Max capacity	: 220 LBS (100 kg)
Net weight	: 70 LBS (31.5 kg)

### **WARNING**

THE ELECTRIC TRISCOOTER IS NOT A TOY AND SHOULD NOT BE OPERATED BY ANY ONE UNDER 12 YEARS OLD.

### **Safety Instruction (Please take note of the followings before each ride)**

- The maximum weight capacity is 100 kg.
- Only one person at a time should ride.
- Always wear protective gear including knee and elbow pads and an approved safety helmet when riding the tri scooter.
- Before riding be sure to check that all pivot points, locking buttons, quick releases, and latches are secured properly.
- The power switch lock must be in the "off" position when the tri scooter is being charged.
- Do not use the tri scooter when it is raining.
- Do not place the battery near heat or fire.
- Do not expose the charger near water.
- Check if battery is properly charged and installed.
- Charge battery after each use.
- Always ride on dry paved surfaces. Wet and uneven surfaces are a hazard.

- Sand and loose impediments are your enemy, avoid them.
- Never operate too fast for your skills or condition.

### **LIST OF PARTS**



1. front mud guard
2. front fork
3. handlebar
4. handlebar quick release
5. handlebar tube clamp
6. seat quick release
7. seat tube quick release
8. seat
9. basket

### Handle Bar

1. brake lever
2. power switch button
3. battery gauge
4. thumb throttle
5. red button: head light
6. green button: horn

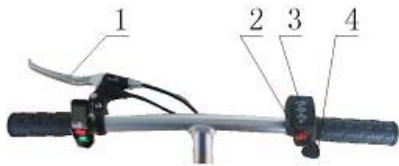

Note: When you begin to ride the scooter, the acceleration power is very high causing the green light on the battery gauge turns to yellow quickly.

This is normal, and will not affect the total range that you will get from the scooter.

### Tool kits in the tool bag



1. Charger
2. Allen wrench (8-10mm)
3. Allen wrench (14- 17mm)
4. Allen wrench (14- 17mm)
5. Screwdriver
6. Wrench (6mm)
7. Wrench (3mm)



Charger convertible cable  
(Optional-For Sale!)

**Fuse** (inside the battery bag)

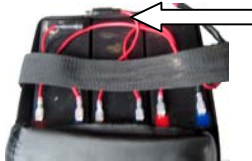

Note: For professional reference only.

## CHARGING THE BATTERIES

Before you ride the tri scooter for the first time you must charge the batteries for 4-6 hours using the supplied charger.

### Charging note:

1. **After charging the battery, it can last for 2-3days. But we still suggest you charge the battery everyday . And you'd better charge the battery 2-3H longer after the full charging. It's good to battery.**
2. **When the battery gauge shows empty,you'd better charge the battery as soon as possible.**
3. **Empty battery is also necessary: Ride the vehicle on the smooth road until it's stop because of the currency protection. After that you can recharge the battery.**

### Option 1:

To charge the batteries, plug the charger into the charger socket located on the rear side of the battery/ controller compartment. Then plug the charger into a wall outlet.



### Option 2: (for professional use only)

Remove the screws from the battery compartment located at the front part of the footboard. Disconnect the wires. Lift the battery box. Connect the battery and charger using the charger convertible cable. Plug the charger into the wall outlet.



## RIDING THE TRI SCOOTER

Once you have completed the initial charge you are ready to ride. Remember, this is not a toy. The tri scooter can reach speeds up to 20 km/h depending on the terrain and the weight of the rider. You must wear a helmet and protective pads. You must also be aware of all local laws and ordinances that govern and/or restrict the use of powered scooters. The laws and ordinances vary greatly from municipality to municipality. It is your responsibility to know and abide by your local restrictions.

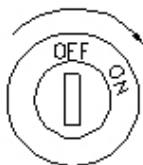

To ride, plug the key into the key ignition and turn the key to the "ON" position. The battery gauge will illuminate indicating that the battery is in operation.

Hold onto the handlebars with both hands. Your left fingers will control the brakes and your right thumb will control the thumb throttle. As you depress the throttle lever with your thumb the speed will increase. Release the thumb throttle and apply the brake to stop the scooter. You will control the speed of the scooter by using both the throttle and the brake. When the brake handle is squeezed it cuts power to the throttle.

NOTE 1: You may use the balancing wheel (the smaller middle rear wheel) to balance the tri scooter when you want to ride with the front wheel raised. **WARNING:** Never try stunts beyond the control of your skills. Never ride too fast for your skills or condition.

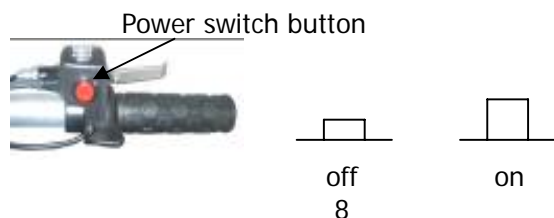

NOTE 2: When scooter is parked, press the power switch button to the "off" position; this will avoid anyone from accidentally pushing the throttle causing the scooter to speed forward. Failure to do this could lead to an accident.

## FOLDING THE TRI SCOOTER

1. Unplug the power connecting plugs.
2. Unscrew the bolts and nuts from the connecting tube clamp using the enclosed allen wrenches .
3. Lift the connecting tube (which is also attached to the handlebar tube).
4. Carefully place the handlebar tube on the footrest frame.
5. Finger screw the bolts and nuts back to the connecting tube clamp to avoid any misplacements.

## MAINTENANCE

Battery: (for professional use only)

The tri scooter is powered by three 12 volts, 7Ah, rechargeable batteries secured in a battery bag. Other than recharging, these batteries need no maintenance. To prolong battery life, you must recharge the battery after each use. You must also charge your tri scooter if it has not been used for 30 days or more. If you must replace the batteries, they are located at the battery compartment at the footboard. To get them, remove the compartment cover by loosening the screws. To remove the batteries disconnect the wires from the battery terminals. Replace the batteries with new ones and reconnect the wires. Follow the instructions on charging batteries to charge the new batteries.

## WIRING DIAGRAM (for professional reference)

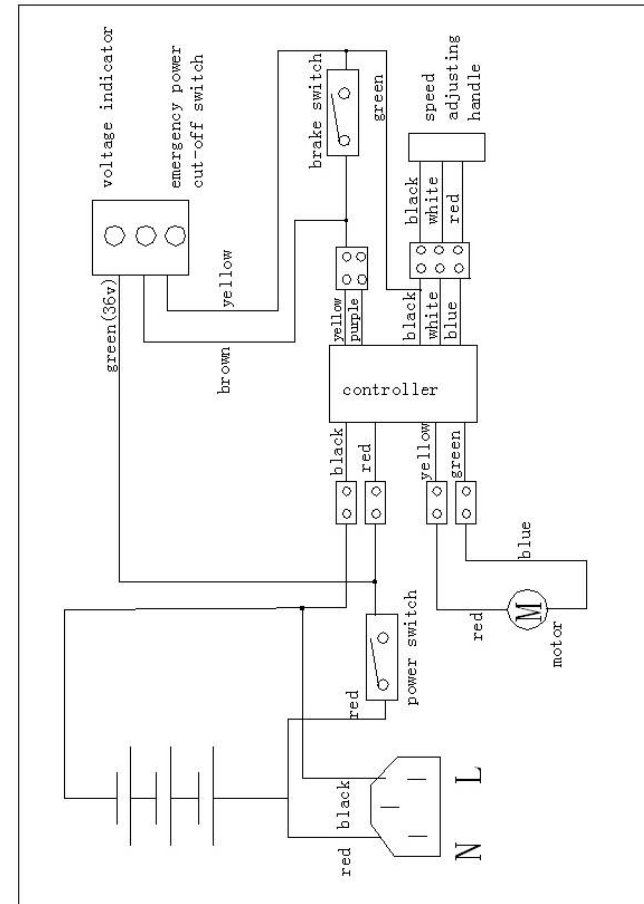

**TROUBLE SHOOTING GUIDE  
(for professional use only)**

Problem	Cause	Solution
The power light by the thumb throttle does not illuminate when the tri scooter is on.	<ol style="list-style-type: none"> <li>1. Battery is discharged.</li> <li>2. Loose connection inside the tri scooter.</li> <li>3. Fuse is blown.</li> </ol>	<ol style="list-style-type: none"> <li>1. Recharge your tri scooter.</li> <li>2. Remove the screws that hold the battery compartment cover and raise the cover. Visually inspect all wire connections making sure there are no loose wires, reconnecting those that are.</li> <li>3. Replace the fuse.</li> </ol>
The power indicator by the thumb throttle illuminates but tri scooter still does not work.	<ol style="list-style-type: none"> <li>1. The throttle handle is not operating properly.</li> </ol>	<ol style="list-style-type: none"> <li>1. Replace the throttle handle. Call Customer Service to order a new throttle</li> </ol>
Clicking noise coming from motor	<ol style="list-style-type: none"> <li>1. Brush in motor has come loose.</li> </ol>	<ol style="list-style-type: none"> <li>1. Replace motor. Call Customer Service to order a new 250w motor.</li> </ol>
When the brake lever is squeezed the tri scooter does not stop.	<ol style="list-style-type: none"> <li>1. The brakes are not adjusted properly.</li> </ol>	<ol style="list-style-type: none"> <li>1. Adjust the brake by loosening the bolt on the rear brake wheel, pull the cable and retighten the bolt.</li> </ol>
Scooter is losing speed.	<ol style="list-style-type: none"> <li>1. Low battery</li> <li>2. Battery is defective</li> </ol>	<ol style="list-style-type: none"> <li>1. Recharge your battery for 4-6 hours.</li> <li>2. Replace battery. Call Customer Service to order a new 36v battery.</li> </ol>